

Model: LUNA2000-213KTL-H0 Smart PCS



Max. Efficiency 99%



Modular Design



IP66 Protection



**Built-in Intelligent
Active Breaking Device**



**Dual-stage
Architecture**



**Smart Grid Forming
Algorithm**

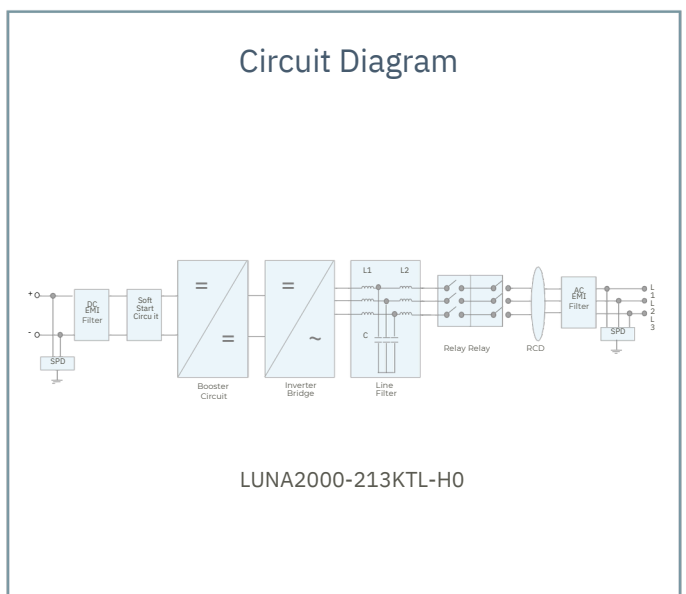
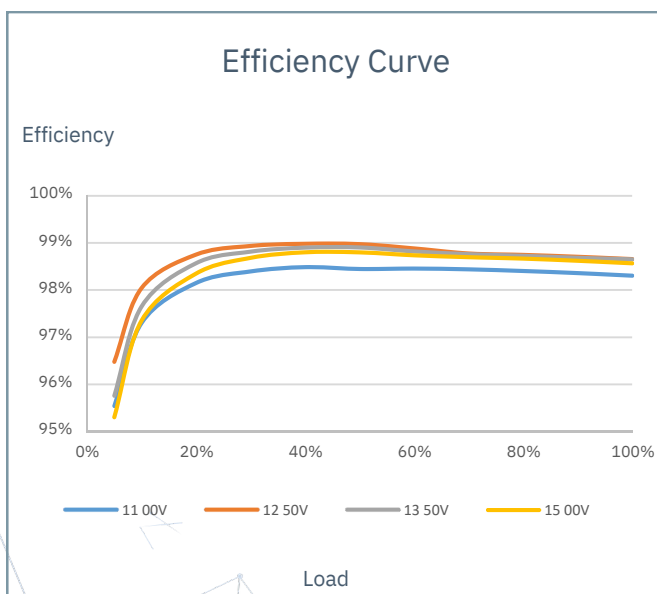

1 - Applies to LUNA2000-4472 series models.

Efficiency	
Max. Efficiency	99.01%
DC Side	
Rated DC Voltage	1,331 V
Max. DC Voltage	1,500 V
Operating DC Voltage Range	800 V ~ 1,500 V
Rated Power Operating Voltage Range	1100V-1500V
Max. DC Current	218.5 A
Max. Number of Inputs	1
AC Side	
Rated AC Active Power	213,000 W @40°C; 192,000 W @50°C
Max. Apparent Power	236,400 VA
Rated AC Voltage	800 V
Rated AC Grid Frequency	50 Hz / 60 Hz
Max. AC Current	170.6 A
Adjustable Power Factor Range	-1 ... +1
Max. Total Harmonic Distortion	THD _i ≤ 1.5%(Rated)
Protection	
AC Overcurrent Protection	Yes
DC Reverse-polarity Protection	Yes
Insulation Resistance Detection	Yes
Residual Current Protection	Yes
DC Surge Protection	Type II
AC Surge Protection	Type II
Communication	
Display	LED Indicators, WLAN + APP
USB	Yes
Communication Protocol	Ethernet, CAN
General	
Dimension (W x H x D)	875 x 865 x 365 mm
Weight	≤110 kg
Operating Temperature Range	-25°C ~ 60°C
Cooling Method	Smart Air Cooling
Max. Operating Altitude without Derating	4,700 m
Relative Humidity	0 ~ 100% (Non-condensing)
DC Connector	OT /DTTerminal
AC Connector	OT /DTTerminal
Protection Degree	IP66
Anti-corrosion Degree	C5-Medium
Topology	Transformerless
Standards Compliance	
GB/T 34120, GB/T 34133, IEC/EN62477-1, etc.	

