

LUNA2000-2.0MWH and 1.0MWH Series Smart String ESS

User Manual

Issue 20
Date 2025-02-10



Copyright © Huawei Technologies Co., Ltd. 2025. All rights reserved.

No part of this document may be reproduced or transmitted in any form or by any means without prior written consent of Huawei Technologies Co., Ltd.

Trademarks and Permissions



HUAWEI and other Huawei trademarks are trademarks of Huawei Technologies Co., Ltd.

All other trademarks and trade names mentioned in this document are the property of their respective holders.

Notice

The purchased products, services and features are stipulated by the contract made between Huawei and the customer. All or part of the products, services and features described in this document may not be within the purchase scope or the usage scope. Unless otherwise specified in the contract, all statements, information, and recommendations in this document are provided "AS IS" without warranties, guarantees or representations of any kind, either express or implied.

The information in this document is subject to change without notice. Every effort has been made in the preparation of this document to ensure accuracy of the contents, but all statements, information, and recommendations in this document do not constitute a warranty of any kind, express or implied.

Huawei Technologies Co., Ltd.

Address: Huawei Industrial Base
Bantian, Longgang
Shenzhen 518129
People's Republic of China

Website: <https://e.huawei.com>

About This Document

Purpose

This document describes the Smart String Energy Storage System (also referred to as ESS) in terms of safety information, components, transportation and storage requirements, site requirements, installation, cable connections, power-on, commissioning, and technical specifications. Read this document carefully before installing and operating the ESS.





Intended Audience

This document is intended for:

- Technical support engineers
- Hardware installation engineers
- Commissioning engineers
- Maintenance engineers

Symbol Conventions

The symbols that may be found in this document are defined as follows.

Symbol	Description
	Indicates a hazard with a high level of risk which, if not avoided, will result in death or serious injury.
	Indicates a hazard with a medium level of risk which, if not avoided, could result in death or serious injury.
	Indicates a hazard with a low level of risk which, if not avoided, could result in minor or moderate injury.
	Indicates a potentially hazardous situation which, if not avoided, could result in equipment damage, data loss, performance deterioration, or unanticipated results. NOTICE is used to address practices not related to personal injury.

Symbol	Description
 NOTE	Supplements the important information in the main text. NOTE is used to address information not related to personal injury, equipment damage, and environment deterioration.

Change History

Changes between document issues are cumulative. The latest document issue contains all the changes made in earlier issues.

Issue 20 (2025-02-10)

Added [5.3.6 \(Optional\) Anti-corrosion Measures on the Bottom of the ESS](#).

Issue 19 (2025-01-30)

Updated [D How Do I Repair Paint Damage?](#).

Issue 18 (2024-11-30)

Updated [4.3 Foundation Requirements](#).

Updated [5.3.5 Securing the ESS](#).

Updated [8.2 Installing the Solenoid Valve](#).

Updated [9 Deployment and Commissioning \(SmartLogger WebUI\)](#).

Updated [13.2 How Do I Ensure that the Solenoid Valve Is Not Activated?](#).

Issue 17 (2024-05-10)

Updated [6.1 Preparing Cables](#).

Issue 16 (2024-03-30)

Added information about the LUNA2000-2.0MWH-HE1H1 model.

Updated [2.1 Model Description](#).

Updated [2.3 Functions and Features](#).

Updated [2.4 Appearance and Layout](#).

Updated [2.5.1 Battery Cabin](#).

Updated [2.5.2 Control Unit Cabin](#).

Updated [2.5.3 Smart Rack Controller Cabin](#).

Updated [2.6.1.1 Battery Pack](#).

Updated [2.6.1.3 Embedded Power Subrack](#).

Updated [2.6.4.5 Fire Cylinder](#).

Updated [5.3.3 Opening the Doors of the ESS](#).

Updated [6.1 Preparing Cables](#).

Updated [6.2 \(Optional\) Installing a Socket](#).

Added [6.4 Installing DC Power Cables \(Double Crimp\)](#).

Updated [8.3 Powering On the ESS](#).

Updated [10.2 Powering Off the ESS](#).

Added [13.8 How Do I Remove Ice When the Cabin Door Is Frozen and Cannot Be Opened?](#).

Updated [14 Technical Specifications](#).

Issue 15 (2023-11-01)

Updated [2.1 Model Description](#).

Updated [2.6.4.4 Extinguishant Control Panel](#).

Updated [2.6.4.12 Water Sprinkler System](#).

Updated [2.7.1 Circuit Diagrams](#).

Updated [2.8 Typical Application Scenarios](#).

Updated [3.2 Storage Requirements](#).

Updated [3.3 Charging Requirements for a Single Battery](#).

Updated [5.4.1 Installing Copper Bars Between Battery Packs](#).

Updated [5.4.3 Installing the Battery in the Extinguishant Control Panel](#).

Updated [9 Deployment and Commissioning \(SmartLogger WebUI\)](#).

Updated [10.2 Powering Off the ESS](#).

Updated [14 Technical Specifications](#).

Added [E Certificate Management and Maintenance](#).

Updated [F Contact Information](#).

Issue 14 (2023-07-30)

Updated [2.4 Appearance and Layout](#).

Issue 13 (2023-06-30)

Updated [2.4 Appearance and Layout](#).

Updated [2.6.4.5 Fire Cylinder](#).

Updated [2.8 Typical Application Scenarios](#).

Issue 12 (2023-06-15)

Updated [2.6.4.9 Smoke Detector](#).

Updated [4.1 Site Selection Requirements](#).

Issue 11 (2023-04-28)

Updated [1.3 Environment Requirements](#).

Updated [5.2 Unpacking and Acceptance](#).

Updated [12 Emergency Handling](#).

Issue 10 (2023-03-30)

Updated [1 Safety Information](#).

Updated [4.1 Site Selection Requirements](#).

Updated [4.3 Foundation Requirements](#).

Issue 09 (2023-02-20)

Updated [1 Safety Information](#).

Updated [3 Transportation and Storage](#).

Updated [4.1 Site Selection Requirements](#).

Updated [4.2 Clearance Requirements](#).

Updated [5.2 Unpacking and Acceptance](#).

Updated [5.3.2 Hoisting the ESS](#).

Updated [5.3.5 Securing the ESS](#).

Updated [5.4.2 Filling the Fire Cylinder with Extinguishant](#).

Updated [5.4.3 Installing the Battery in the Extinguishant Control Panel](#).

Updated [6.6 \(Optional\) Installing Single-Phase AC Input Power Cables](#).

Updated [8.2 Installing the Solenoid Valve](#).

Updated [12 Emergency Handling](#).

Issue 08 (2022-11-15)

Updated [2.4 Appearance and Layout](#).

Updated [2.5.1 Battery Cabin](#).

Updated [2.5.2 Control Unit Cabin](#).

Updated [2.7.1 Circuit Diagrams](#).

Updated [2.8 Typical Application Scenarios](#).

Updated [6.1 Preparing Cables](#).

Updated [6.2 \(Optional\) Installing a Socket](#).
Updated [6.6 \(Optional\) Installing Single-Phase AC Input Power Cables](#).
Updated [8.1 Installing the PSU](#).
Updated [8.2 Installing the Solenoid Valve](#).
Updated [8.3 Powering On the ESS](#).
Updated [A.2.1 Preparations and WebUI Login](#).
Updated [9 Deployment and Commissioning \(SmartLogger WebUI\)](#).
Updated [10.2 Powering Off the ESS](#).
Updated [13.7 How Do I Perform a Dielectric Voltage Withstand Test on the AC Side of an ESS?](#).
Updated [14 Technical Specifications](#).

Issue 07 (2022-06-30)

Updated [4.3 Foundation Requirements](#). Updated the diagram of foundation.
Updated [11 Alarm Reference](#).
Updated [14 Technical Specifications](#), and added LUNA2000-2.0MWH-1H1.

Issue 06 (2022-06-08)

Updated [5 Installation](#).
Updated [8.2 Installing the Solenoid Valve](#).
Updated [9 Deployment and Commissioning \(SmartLogger WebUI\)](#).

Issue 05 (2022-04-30)

Updated [5.4.1 Installing Copper Bars Between Battery Packs](#).
Updated [5.4.2 Filling the Fire Cylinder with Extinguishant](#).
Updated [13.7 How Do I Perform a Dielectric Voltage Withstand Test on the AC Side of an ESS?](#).

Issue 04 (2022-03-30)

Updated [About This Document](#).
Updated [2 Overview](#).
Updated [2.7.2 Working Modes](#).
Updated [5.3.4 Grounding the ESS](#).
Updated [5.3.5 Securing the ESS](#).
Updated [5.4.2 Filling the Fire Cylinder with Extinguishant](#).
Updated [6.8 Sealing the Cable Holes](#).

Updated [8.1 Installing the PSU](#).

Updated [8.2 Installing the Solenoid Valve](#).

Updated [9 Deployment and Commissioning \(SmartLogger WebUI\)](#).

Updated [10 Powering Off the System](#).

Updated [11 Alarm Reference](#).

Updated [13.6 What Should I Do If the ESU Cable Connection Detection Abnormal Alarm Is Generated on the WebUI?](#).

Updated [14 Technical Specifications](#).

Issue 03 (2022-01-04)

Updated [1 Safety Information](#).

Updated [4 Site Requirements](#).

Issue 02 (2021-11-15)

Updated [1.3 Environment Requirements](#).

Updated [1.4 Mechanical Safety](#).

Updated [1.5 Equipment Safety](#).

Updated [2 Overview](#).

Updated [4.2 Clearance Requirements](#).

Updated [4.3 Foundation Requirements](#).

Updated [5.3 Installing the ESS](#).

Updated [5.4 Installing Components](#).

Updated [6 Installing Cables](#).

Updated [8.3 Powering On the ESS](#).

Updated [9 Deployment and Commissioning \(SmartLogger WebUI\)](#).

Updated [10.2 Powering Off the ESS](#).

Updated [11 Alarm Reference](#).

Updated [13 FAQ](#).

Issue 01 (2021-08-30)

This issue is used for first office application (FOA).

Contents

About This Document.....	ii
1 Safety Information.....	1
1.1 Personal Safety.....	2
1.2 Electrical Safety.....	4
1.3 Environment Requirements.....	8
1.4 Mechanical Safety.....	10
1.5 Equipment Safety.....	15
1.5.1 ESS Safety.....	15
1.5.2 Battery Safety.....	16
2 Overview.....	22
2.1 Model Description.....	22
2.2 Label Description.....	24
2.3 Functions and Features.....	25
2.4 Appearance and Layout.....	25
2.5 ESS Composition.....	30
2.5.1 Battery Cabin.....	31
2.5.2 Control Unit Cabin.....	36
2.5.3 Smart Rack Controller Cabin.....	46
2.6 Components.....	48
2.6.1 Power Supply and Distribution System.....	48
2.6.1.1 Battery Pack.....	48
2.6.1.2 Smart Rack Controller.....	50
2.6.1.3 Embedded Power Subrack.....	51
2.6.1.4 PSU.....	53
2.6.1.5 SMU.....	55
2.6.2 Monitoring System.....	59
2.6.2.1 CMU.....	59
2.6.2.2 SmartModule.....	61
2.6.2.3 I/O Expansion Board.....	62
2.6.3 Environmental Control System.....	63
2.6.3.1 T/H Sensor.....	64
2.6.3.2 Air Conditioner in the Control Unit Cabin.....	65

2.6.3.3 Air Conditioner in the Battery Cabin.....	66
2.6.3.4 Electrode Water Sensor.....	67
2.6.3.5 Door Status Sensor.....	68
2.6.3.6 Light.....	69
2.6.4 Fire Suppression System.....	69
2.6.4.1 CO Sensor.....	70
2.6.4.2 Air Exhaust Module.....	71
2.6.4.3 Air Exhaust Controller.....	71
2.6.4.4 Extinguishant Control Panel.....	72
2.6.4.5 Fire Cylinder.....	75
2.6.4.6 Input/Output Module.....	78
2.6.4.7 Fire Signal Transfer Board.....	80
2.6.4.8 Heat Detector.....	81
2.6.4.9 Smoke Detector.....	82
2.6.4.10 Fire Alarm Horn/Strobe.....	84
2.6.4.11 Extinguishant Release Indicator.....	87
2.6.4.12 Water Sprinkler System.....	88
2.7 Working Principles.....	91
2.7.1 Circuit Diagrams.....	91
2.7.2 Working Modes.....	104
2.8 Typical Application Scenarios.....	105
3 Transportation and Storage.....	106
3.1 Transportation Requirements.....	106
3.2 Storage Requirements.....	109
3.3 Charging Requirements for a Single Battery.....	113
4 Site Requirements.....	117
4.1 Site Selection Requirements.....	117
4.2 Clearance Requirements.....	120
4.3 Foundation Requirements.....	120
5 Installation.....	122
5.1 Installation Preparations.....	122
5.1.1 Preparing Tools.....	122
5.1.2 Installation Environment Check.....	125
5.2 Unpacking and Acceptance.....	125
5.3 Installing the ESS.....	125
5.3.1 Determining the Installation Position of the ESS.....	125
5.3.2 Hoisting the ESS.....	126
5.3.3 Opening the Doors of the ESS.....	129
5.3.4 Grounding the ESS.....	131
5.3.5 Securing the ESS.....	134
5.3.6 (Optional) Anti-corrosion Measures on the Bottom of the ESS.....	136

5.4 Installing Components.....	138
5.4.1 Installing Copper Bars Between Battery Packs.....	139
5.4.2 Filling the Fire Cylinder with Extinguishant.....	143
5.4.3 Installing the Battery in the Extinguishant Control Panel.....	146
6 Installing Cables.....	150
6.1 Preparing Cables.....	150
6.2 (Optional) Installing a Socket.....	152
6.3 Installing DC Power Cables (Single Crimp).....	160
6.4 Installing DC Power Cables (Double Crimp).....	165
6.5 Installing an AC Input Power Cable (With External Grid Power Supply).....	172
6.6 (Optional) Installing Single-Phase AC Input Power Cables.....	177
6.7 Installing Signal Cables.....	179
6.7.1 Installing FE Communications Cables.....	179
6.7.2 Installing Optical Fiber Cables.....	182
6.8 Sealing the Cable Holes.....	186
7 Check Before Power-On.....	187
8 Powering On the System.....	189
8.1 Installing the PSU.....	189
8.2 Installing the Solenoid Valve.....	191
8.3 Powering On the ESS.....	195
9 Deployment and Commissioning (SmartLogger WebUI).....	205
10 Powering Off the System.....	206
10.1 Sending a Shutdown Command on the SmartLogger.....	206
10.2 Powering Off the ESS.....	207
11 Alarm Reference.....	210
12 Emergency Handling.....	211
13 FAQ.....	213
13.1 (Optional) How Do I Level the ESS When Doors Cannot Be Opened or Closed?.....	213
13.2 How Do I Ensure that the Solenoid Valve Is Not Activated?.....	214
13.3 How Do I Connect the ESS to the Smart PV Management System?.....	215
13.4 How Do I Create a Plant?.....	216
13.5 Why Does the PSU Not Start After the Water and Fire Alarms Are Cleared.....	216
13.6 What Should I Do If the ESU Cable Connection Detection Abnormal Alarm Is Generated on the WebUI?.....	217
13.7 How Do I Perform a Dielectric Voltage Withstand Test on the AC Side of an ESS?.....	217
13.8 How Do I Remove Ice When the Cabin Door Is Frozen and Cannot Be Opened?.....	219
14 Technical Specifications.....	221
A Operations on the CMU WebUI.....	227
A.1 CMU WebUI Operations.....	227

A.1.1 WebUI Layout.....	227
A.1.2 Icon Description.....	228
A.1.3 WebUI Menus.....	229
A.2 Maintenance Operations.....	231
A.2.1 Preparations and WebUI Login.....	231
A.2.2 Upgrading the Software Version.....	236
A.2.3 Exporting Device Logs.....	236
A.2.4 Checking Alarms.....	237
A.2.5 Clearing Alarms.....	237
B App Operations.....	238
B.1 Downloading and Installing the App.....	238
B.2 Logging In to the App.....	238
B.3 Change Password.....	240
C Crimping an OT or DT Terminal.....	242
D How Do I Repair Paint Damage?.....	245
E Certificate Management and Maintenance.....	249
F Contact Information.....	251
G Acronyms and Abbreviations.....	253

1 Safety Information

Statement

Before transporting, storing, installing, operating, using, and/or maintaining the equipment, read this document, strictly follow the instructions provided herein, and follow all the safety instructions on the equipment and in this document. In this document, "equipment" refers to the products, software, components, spare parts, and/or services related to this document; "the Company" refers to the manufacturer (producer), seller, and/or service provider of the equipment; "you" refers to the entity that transports, stores, installs, operates, uses, and/or maintains the equipment.

The **Danger, Warning, Caution, and Notice** statements described in this document do not cover all the safety precautions. You also need to comply with relevant international, national, or regional standards and industry practices. **The Company shall not be liable for any consequences that may arise due to violations of safety requirements or safety standards concerning the design, production, and usage of the equipment.**

The equipment shall be used in an environment that meets the design specifications. Otherwise, the equipment may be faulty, malfunctioning, or damaged, which is not covered under the warranty. The Company shall not be liable for any property loss, personal injury, or even death caused thereby.

Comply with applicable laws, regulations, standards, and specifications during transportation, storage, installation, operation, use, and maintenance.

Do not perform reverse engineering, decompilation, disassembly, adaptation, implantation, or other derivative operations on the equipment software. Do not study the internal implementation logic of the equipment, obtain the source code of the equipment software, violate intellectual property rights, or disclose any of the performance test results of the equipment software.

The Company shall not be liable for any of the following circumstances or their consequences:

- The equipment is damaged due to force majeure such as earthquakes, floods, volcanic eruptions, debris flows, lightning strikes, fires, wars, armed conflicts, typhoons, hurricanes, tornadoes, and other extreme weather conditions.
- The equipment is operated beyond the conditions specified in this document.

- The equipment is installed or used in environments that do not comply with international, national, or regional standards.
- The equipment is installed or used by unqualified personnel.
- You fail to follow the operation instructions and safety precautions on the product and in the document.
- You remove or modify the product or modify the software code without authorization.
- You or a third party authorized by you cause the equipment damage during transportation.
- The equipment is damaged due to storage conditions that do not meet the requirements specified in the product document.
- You fail to prepare materials and tools that comply with local laws, regulations, and related standards.
- The equipment is damaged due to your or a third party's negligence, intentional breach, gross negligence, or improper operations, or other reasons not related to the Company.

1.1 Personal Safety

 **DANGER**

Ensure that power is off during installation. Do not install or remove a cable with power on. Transient contact between the core of the cable and the conductor will cause electric arcs, sparks, fire, or explosion, which may result in personal injury.

 **DANGER**

Non-standard and improper operations on the energized equipment may cause fire, electric shocks, or explosion, resulting in property damage, personal injury, or even death.

 **DANGER**

Before operations, remove conductive objects such as watches, bracelets, bangles, rings, and necklaces to prevent electric shocks.

 **DANGER**

During operations, use dedicated insulated tools to prevent electric shocks or short circuits. The dielectric withstanding voltage level must comply with local laws, regulations, standards, and specifications.

WARNING

During operations, wear personal protective equipment such as protective clothing, insulated shoes, goggles, safety helmets, and insulated gloves.

Figure 1-1 Personal protective equipment

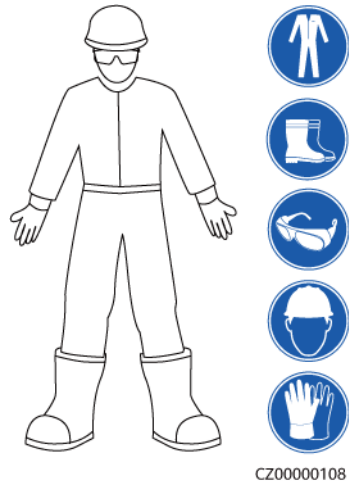

General Requirements

- Do not stop protective devices. Pay attention to the warnings, cautions, and related precautionary measures in this document and on the equipment.
- If there is a likelihood of personal injury or equipment damage during operations, immediately stop, report the case to the supervisor, and take feasible protective measures.
- Do not power on the equipment before it is installed or confirmed by professionals.
- Do not touch the power supply equipment directly or with conductors such as damp objects. Before touching any conductor surface or terminal, measure the voltage at the contact point to ensure that there is no risk of electric shock.
- Do not touch operating equipment because the enclosure is hot.
- Do not touch a running fan with your hands, components, screws, tools, or boards. Otherwise, personal injury or equipment damage may occur.
- In the case of a fire, immediately leave the building or the equipment area and activate the fire alarm or call emergency services. Do not enter the affected building or equipment area under any circumstances.

Personnel Requirements

- Only professionals and trained personnel are allowed to operate the equipment.
 - Professionals: personnel who are familiar with the working principles and structure of the equipment, trained or experienced in equipment operations and are clear of the sources and degree of various potential hazards in equipment installation, operation, maintenance

- Trained personnel: personnel who are trained in technology and safety, have required experience, are aware of possible hazards on themselves in certain operations, and are able to take protective measures to minimize the hazards on themselves and other people
- Personnel who plan to install or maintain the equipment must receive adequate training, be able to correctly perform all operations, and understand all necessary safety precautions and local relevant standards.
- Only qualified professionals or trained personnel are allowed to install, operate, and maintain the equipment.
- Only qualified professionals are allowed to remove safety facilities and inspect the equipment.
- Personnel who will perform special tasks such as electrical operations, working at heights, and operations of special equipment must possess the required local qualifications.
- Only authorized professionals are allowed to replace the equipment or components (including software).
- Only personnel who need to work on the equipment are allowed to access the equipment.

1.2 Electrical Safety

 **DANGER**

Before connecting cables, ensure that the equipment is intact. Otherwise, electric shocks or fire may occur.

 **DANGER**

Non-standard and improper operations may result in fire or electric shocks.

 **DANGER**

Prevent foreign matter from entering the equipment during operations. Otherwise, equipment short-circuits or damage, load power derating, power failure, or personal injury may occur.

 **WARNING**

For the equipment that needs to be grounded, install the ground cable first when installing the equipment and remove the ground cable last when removing the equipment.

 **CAUTION**

Do not route cables near the air intake or exhaust vents of the equipment.

General Requirements

- Follow the procedures described in the document for installation, operation, and maintenance. Do not reconstruct or alter the equipment, add components, or change the installation sequence without permission.
- Obtain approval from the national or local electric utility company before connecting the equipment to the grid.
- Observe the power plant safety regulations, such as the operation and work ticket mechanisms.
- Install temporary fences or warning ropes and hang "No Entry" signs around the operation area to keep unauthorized personnel away from the area.
- Before installing or removing power cables, turn off the switches of the equipment and its upstream and downstream switches.
- If any liquid is detected inside the equipment, disconnect the power supply immediately and do not use the equipment.
- Before performing operations on the equipment, check that all tools meet the requirements and record the tools. After the operations are complete, collect all of the tools to prevent them from being left inside the equipment.
- Before installing power cables, check that cable labels are correct and cable terminals are insulated.
- When installing the equipment, use a torque tool of a proper measurement range to tighten the screws. When using a wrench to tighten the screws, ensure that the wrench does not tilt and the torque error does not exceed 10% of the specified value.
- Ensure that bolts are tightened with a torque tool and marked in red and blue after double-check. Installation personnel mark tightened bolts in blue. Quality inspection personnel confirm that the bolts are tightened and then mark them in red. (The marks must cross the edges of the bolts.)

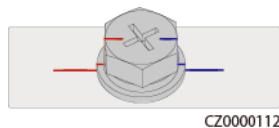

- After the installation is complete, ensure that protective cases, insulation tubes, and other necessary items for all electrical components are in position to avoid electric shocks.
- If the equipment has multiple inputs, disconnect all the inputs and wait until the equipment is completely powered off before performing operations on the equipment.
- Before maintaining a downstream electrical or power distribution device, turn off the output switch on the power supply equipment.
- During equipment maintenance, attach "Do not switch on" labels near the upstream and downstream switches or circuit breakers as well as warning signs to prevent accidental connection. The equipment can be powered on only after troubleshooting is complete.

- If fault diagnosis and troubleshooting need to be performed after power-off, take the following safety measures: Disconnect the power supply. Check whether the equipment is live. Install a ground cable. Hang warning signs and set up fences.
- Check equipment connections periodically, ensuring that all screws are securely tightened.
- Only qualified professionals can replace a damaged cable.
- Do not scrawl, damage, or block any labels or nameplates on the equipment. Promptly replace labels that have worn out.
- Do not use solvents such as water, alcohol, or oil to clean electrical components inside or outside of the equipment.

Grounding

- Ensure that the grounding impedance of the equipment complies with local electrical standards.
- Ensure that the equipment is connected permanently to the protective ground. Before operating the equipment, check its electrical connection to ensure that it is reliably grounded.
- Do not work on the equipment in the absence of a properly installed ground conductor.
- Do not damage the ground conductor.
- For the equipment that uses a three-pin socket, ensure that the ground terminal in the socket is connected to the protective ground point.
- If high touch current may occur on the equipment, ground the protective ground terminal on the equipment enclosure before connecting the power supply; otherwise, electric shock as a result of touch current may occur.

Cabling Requirements

- When selecting, installing, and routing cables, follow local safety regulations and rules.
- When routing power cables, ensure that there is no coiling or twisting. Do not join or weld power cables. If necessary, use a longer cable.
- Ensure that all cables are properly connected and insulated, and meet specifications.
- Ensure that the slots and holes for routing cables are free from sharp edges, and that the positions where cables are routed through pipes or cable holes are equipped with cushion materials to prevent the cables from being damaged by sharp edges or burrs.
- If a cable is routed into the cabinet from the top, bend the cable in a U shape outside the cabinet and then route it into the cabinet.
- Ensure that cables of the same type are bound together neatly and straight and that the cable sheath is intact. When routing cables of different types, ensure that they are at least 30 mm away from each other.
- When cable connection is completed or paused for a short period of time, seal the cable holes with sealing putty immediately to prevent small animals or moisture from entering.

- Secure buried cables using cable supports and cable clips. Ensure that the cables in the backfill area are in close contact with the ground to prevent cable deformation or damage during backfilling.
- If the external conditions (such as the cable layout or ambient temperature) change, verify the cable usage in accordance with the IEC-60364-5-52 or local laws and regulations. For example, check that the current-carrying capacity meets requirements.
- When routing cables, reserve at least 30 mm clearance between the cables and heat-generating components or areas. This prevents deterioration or damage to the cable insulation layer.
- When the temperature is low, violent impact or vibration may damage the plastic cable sheathing. To ensure safety, comply with the following requirements:
 - Cables can be laid or installed only when the temperature is higher than 0°C. Handle cables with caution, especially at a low temperature.
 - Cables stored at below 0°C must be stored at room temperature for more than 24 hours before they are laid out.
- Do not perform any improper operations, for example, dropping cables directly from a vehicle. Otherwise, the cable performance may deteriorate due to cable damage, which affects the current-carrying capacity and temperature rise.

ESD

NOTICE

The static electricity generated by human bodies may damage the electrostatic-sensitive components on boards, for example, the large-scale integrated (LSI) circuits.

-
- When touching the equipment and handling boards, modules with exposed circuit boards, or application-specific integrated circuits (ASICs), observe ESD protection regulations and wear ESD clothing and ESD gloves or a well-grounded ESD wrist strap.

Figure 1-2 Wearing an ESD wrist strap

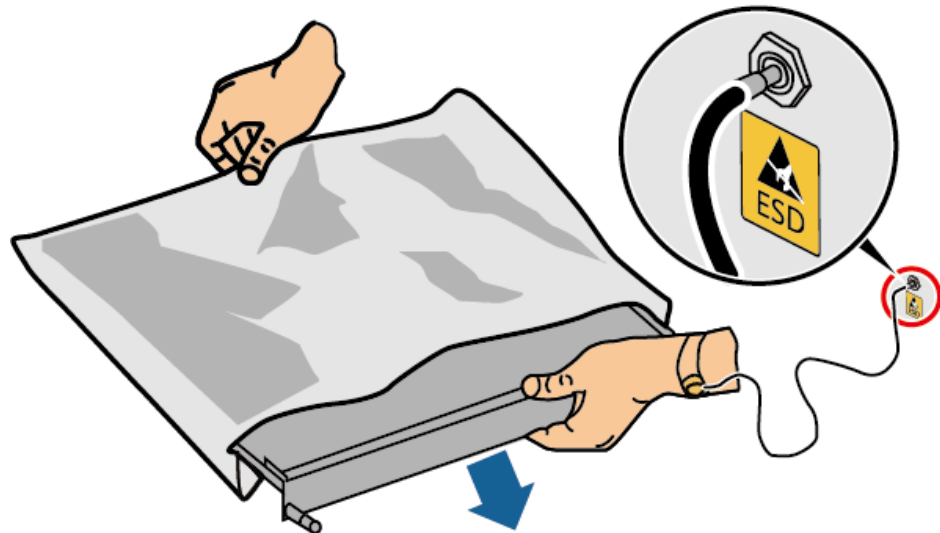

DC15000001

- When holding a board or a module with exposed circuit boards, hold its edge without touching any components. Do not touch the components with bare hands.
- Package boards or modules with ESD packaging materials before storing or transporting them.

1.3 Environment Requirements

⚠ DANGER

Do not expose the equipment to flammable or explosive gas or smoke. Do not perform any operation on the equipment in such environments.

⚠ DANGER

Do not store any flammable or explosive materials in the equipment area.

⚠ DANGER

Do not place the equipment near heat sources or fire sources, such as smoke, candles, heaters, or other heating devices. Overheat may damage the equipment or cause a fire.

 **WARNING**

Install the equipment in an area far away from liquids. Do not install it under areas prone to condensation, such as under water pipes and air exhaust vents, or areas prone to water leakage, such as air conditioner vents, ventilation vents, or feeder windows of the equipment room. Ensure that no liquid enters the equipment to prevent faults or short circuits.

 **WARNING**

To prevent damage or fire due to high temperature, ensure that the ventilation vents or heat dissipation systems are not obstructed or covered by other objects while the equipment is running.

General Requirements

- Ensure that the equipment is stored in a clean, dry, and well ventilated area with proper temperature and humidity and is protected from dust and condensation.
- Keep the installation and operating environments of the equipment within the allowed ranges. Otherwise, its performance and safety will be compromised.
- Do not install, use, or operate outdoor equipment and cables (including but not limited to moving equipment, operating equipment and cables, inserting connectors to or removing connectors from signal ports connected to outdoor facilities, working at heights, performing outdoor installation, and opening doors) in harsh weather conditions such as lightning, rain, snow, sandstorm, and level 6 or stronger wind.
- Do not install the equipment in an environment with dust, smoke, volatile or corrosive gases, infrared and other radiations, organic solvents, or salty air.
- Do not install the equipment in an environment with conductive metal or magnetic dust.
- Do not install the equipment in an area conducive to the growth of microorganisms such as fungus or mildew.
- Do not install the equipment in an area with strong vibration, noise, or electromagnetic interference.
- Ensure that the site complies with local laws, regulations, and related standards.
- Ensure that the ground in the installation environment is solid, free from spongy or soft soil, and not prone to subsidence. The site must not be located in a low-lying land prone to water or snow accumulation, and the horizontal level of the site must be above the highest water level of that area in history.
- Do not install the equipment in a position that may be submerged in water.
- If the equipment is installed in a place with abundant vegetation, in addition to routine weeding, harden the ground underneath the equipment using cement or gravel.
- Before opening doors during the installation, operation, and maintenance of the equipment, clean up any water, ice, snow, or other foreign objects on the

top of the equipment to prevent foreign objects from falling into the equipment.

- When installing the equipment, ensure that the installation surface is solid enough to bear the weight of the equipment.
- All cable holes must be sealed. Seal the used cable holes with sealing putty. Seal the unused cable holes with the caps delivered with the equipment. The following figure shows the criteria for correct sealing with sealing putty.

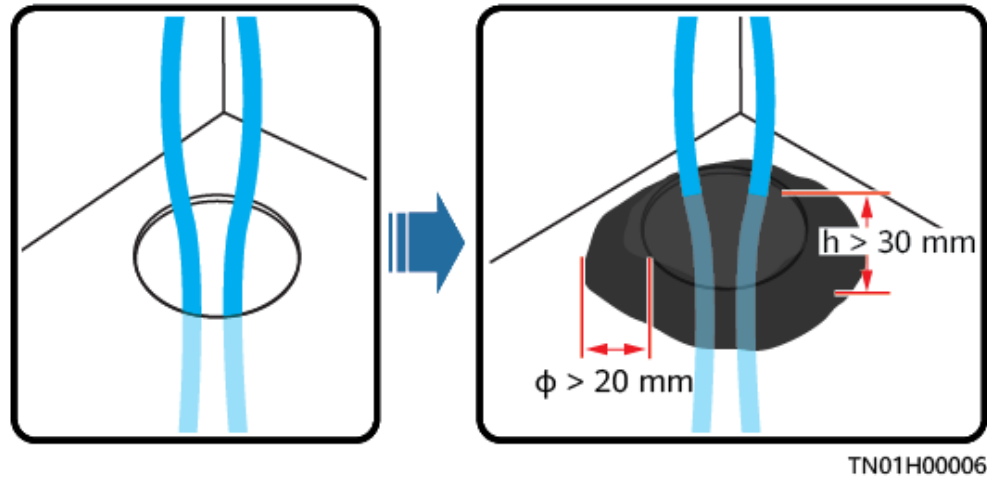

- After installing the equipment, remove the packing materials such as cartons, foam, plastics, and cable ties from the equipment area.

1.4 Mechanical Safety

⚠ DANGER

When working at heights, wear a safety helmet and safety harness or waist belt and fasten it to a solid structure. Do not mount it on an insecure moveable object or metal object with sharp edges. Make sure that the hooks will not slide off.

⚠ WARNING

Ensure that all necessary tools are ready and inspected by a professional organization. Do not use tools that have signs of scratches or fail to pass the inspection or whose inspection validity period has expired. Ensure that the tools are secure and not overloaded.

⚠ WARNING

Before installing equipment in a cabinet, ensure that the cabinet is securely fastened with a balanced center of gravity. Otherwise, tipping or falling cabinets may cause bodily injury and equipment damage.

 **WARNING**

When pulling equipment out of a cabinet, be aware of unstable or heavy objects in the cabinet to prevent injury.

 **WARNING**

Do not drill holes into the equipment. Doing so may affect the sealing performance and electromagnetic containment of the equipment and damage components or cables inside. Metal shavings from drilling may short-circuit boards inside the equipment.

General Requirements

- Repaint any paint scratches caused during equipment transportation or installation in a timely manner. Equipment with scratches must not be exposed for an extended period of time.
- Do not perform operations such as arc welding and cutting on the equipment without evaluation by the Company.
- Do not install other devices on the top of the equipment without evaluation by the Company.
- When performing operations over the top of the equipment, take measures to protect the equipment against damage.
- Use correct tools and operate them in the correct way.

Moving Heavy Objects

- Be cautious to prevent injury when moving heavy objects.



< 18 kg
(< 40 lbs)



18–32 kg
(40–70 lbs)



32–55 kg
(70–121 lbs)

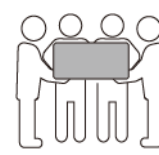

55–68 kg
(121–150 lbs)



> 68 kg
(> 150 lbs)

CZ0000110

- If multiple persons need to move a heavy object together, determine the manpower and work division with consideration of height and other conditions to ensure that the weight is equally distributed.
- If two persons or more move a heavy object together, ensure that the object is lifted and landed simultaneously and moved at a uniform pace under the supervision of one person.
- Wear personal protective gears such as protective gloves and shoes when manually moving the equipment.
- To move an object by hand, approach to the object, squat down, and then lift the object gently and stably by the force of the legs instead of your back. Do not lift it suddenly or turn your body around.
- Move or lift the equipment by holding its handles or lower edges. Do not hold the handles of modules that are installed in the equipment.

- Do not quickly lift a heavy object above your waist. Place the object on a workbench that is half-waist high or any other appropriate place, adjust the positions of your palms, and then lift it.
- Move a heavy object stably with balanced force at an even and low speed. Put down the object stably and slowly to prevent any collision or drop from scratching the surface of the equipment or damaging the components and cables.
- When moving a heavy object, be aware of the workbench, slope, staircase, and slippery places. When moving a heavy object through a door, ensure that the door is wide enough to move the object and avoid bumping or injury.
- When transferring a heavy object, move your feet instead of turning your waist around. When lifting and transferring a heavy object, ensure that your feet point to the target direction of movement.
- When transporting the equipment using a pallet truck or forklift, ensure that the tynes are properly positioned so that the equipment does not topple. Before moving the equipment, secure it to the pallet truck or forklift using ropes. When moving the equipment, assign dedicated personnel to take care of it.
- Choose sea or roads in good conditions for transportation. Do not transport the equipment by railway or air. Avoid tilt or jolt during transportation.
- The tilt angle of the ESS shall meet the requirements shown in the figure: $\alpha \leq 5^\circ$.

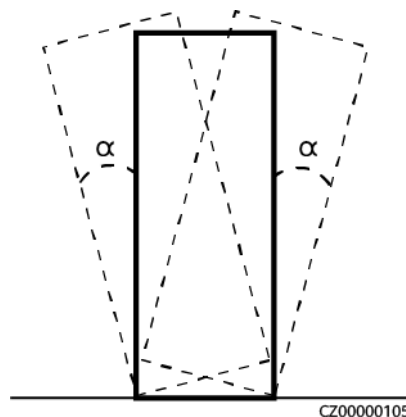

- When moving and transporting an air conditioner, keep it upright and do not place it horizontally or upside down. If the package of the air conditioner is damaged or the tilt indicator on the package changes color, contact the Company's service engineers.

Working at Heights

- Any operations performed 2 m or higher above the ground shall be supervised properly.
- Only trained and qualified personnel are allowed to work at heights.
- Do not work at heights when steel pipes are wet or other risky situations exist. After the preceding conditions no longer exist, the safety owner and relevant technical personnel need to check the involved equipment. Operators can begin working only after safety is confirmed.
- Set a restricted area and prominent signs for working at heights to warn away irrelevant personnel.

- Set guard rails and warning signs at the edges and openings of the area involving working at heights to prevent falls.
- Do not pile up scaffolding, springboards, or other objects on the ground under the area involving working at heights. Do not allow people to stay or pass under the area involving working at heights.
- Carry operation machines and tools properly to prevent equipment damage or personal injury caused by falling objects.
- Personnel involving working at heights are not allowed to throw objects from the height to the ground, or vice versa. Objects shall be transported by slings, hanging baskets, aerial work platforms, or cranes.
- Do not perform operations on the upper and lower layers at the same time. If unavoidable, install a dedicated protective shelter between the upper and lower layers or take other protective measures. Do not pile up tools or materials on the upper layer.
- Dismantle the scaffolding from top down after finishing the job. Do not dismantle the upper and lower layers at the same time. When removing a part, ensure that other parts will not collapse.
- Ensure that personnel working at heights strictly comply with the safety regulations. The Company is not responsible for any accident caused by violation of the safety regulations on working at heights.
- Behave cautiously when working at heights. Do not rest at heights.

Using Ladders

- Use wooden or insulated ladders when you need to perform live-line working at heights.
- Platform ladders with protective rails are preferred. Do not use single ladders.
- Before using a ladder, check that it is intact and confirm its load bearing capacity. Do not overload it.
- Ensure that the ladder is securely positioned and held firm.



CZ00000107

- When climbing up the ladder, keep your body stable and your center of gravity between the side rails, and do not overreach to the sides.
- When a step ladder is used, ensure that the pull ropes are secured.

Hoisting

- Only trained and qualified personnel are allowed to perform hoisting operations.

- Install temporary warning signs or fences to isolate the hoisting area.
- Ensure that the foundation where hoisting is performed on meets the load-bearing requirements.
- Before hoisting objects, ensure that hoisting tools are firmly secured onto a fixed object or wall that meets the load-bearing requirements.
- During hoisting, do not stand or walk under the crane or the hoisted objects.
- Do not drag steel ropes and hoisting tools or bump the hoisted objects against hard objects during hoisting.
- Ensure that the angle between two hoisting ropes is no more than 90 degrees, as shown in the following figure.

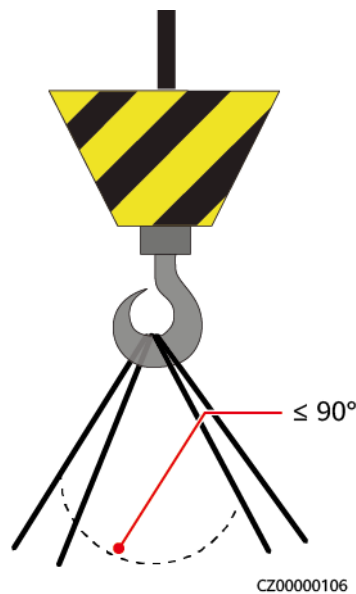

Drilling Holes

- Obtain consent from the customer and contractor before drilling holes.
- Wear protective equipment such as safety goggles and protective gloves when drilling holes.
- To avoid short circuits or other risks, do not drill holes into buried pipes or cables.
- When drilling holes, protect the equipment from shavings. After drilling, clean up any shavings.

Welding

- A welder must have a work permit. Obtain consent from the customer before welding.
- Ensure that at least two persons are present onsite for welding and that fire extinguishers, wet cloth, and water containers are available.
- Ensure that the welding site is free from inflammables.
- Do not weld or cut on pressurized containers or pipes. Electric devices must be powered off before welding.
- A burning welding torch must not be placed on a component or on the floor, and must not be placed in a metal container with acetylene and oxygen. Otherwise, the gas may leak and cause a fire.

- High-temperature pipes after welding must be promptly cooled.

Using a Jack

- A hydraulic jack is used to lift the container. Load bearing requirement: 30 t
- Only one side of the equipment can be raised or lowered. Before applying force, place wood sleepers and pads and take measures to prevent the jack from slipping and the equipment from vibrating.
- You can use two jacks to apply even forces simultaneously at two points on a short side of the equipment. Lift the equipment only from one side and then the other side, alternately. The height shall not exceed 120 mm each time the equipment is lifted.

1.5 Equipment Safety

1.5.1 ESS Safety

 **DANGER**

Do not open battery cabin doors when the system is running.

 **DANGER**

If the ESS is faulty, do not stand within the opening range of the battery cabin doors.

 **CAUTION**

The equipment is equipped with a fire suppression system. Start the fire suppression system only in emergency.

 **CAUTION**

Do not disable the protection devices.

 **CAUTION**

Evacuate from the site immediately once the fire alarm horn/strobe is triggered.

NOTICE

Take protection and isolation measures for the ESS site, such as installing fences, walls, and safety warning signs to prevent personal injury or property damage caused by unauthorized access during operations.

-
- When installing the ESS, comply with the fire separation distance or fire wall requirements specified in local standards, including but not limited to *GB 51048-2014 Design Code for Electrochemical Energy Storage Station* and *NFPA 855 Standard for the Installation of Stationary Energy Storage Systems*.
 - Check the fire safety of the ESS regularly, at least once a month.
 - When inspecting the system with power on, pay attention to the hazard warning signs on the equipment. Do not stand at the battery cabin doors. You are advised to perform the inspection near the control unit cabin.
 - After power components of the ESS are replaced or cable connections are changed, you need to manually start cable connection detection and topology identification to prevent system malfunction.
 - After the equipment is powered off, wait for 15 minutes and ensure that the equipment is not energized before operations.
 - It is recommended that you prepare a camera to record the detailed processes of equipment installation, operation, and maintenance.

1.5.2 Battery Safety

DANGER

Do not connect the positive and negative poles of a battery together. Otherwise, the battery may be short-circuited. Battery short circuits can generate high instantaneous current and releases a large amount of energy, which will cause battery leakage, smoke, flammable gas release, thermal runaway, fire, or explosion. To avoid battery short circuits, do not maintain batteries with power on.

DANGER

Do not expose batteries at high temperatures or around heat sources, such as scorching sunlight, fire sources, transformers, and heaters. Battery overheating may cause leakage, smoke, flammable gas release, thermal runaway, fire, or explosion.

DANGER

Protect batteries from mechanical vibration, falling, collision, punctures, and strong impact. Otherwise, the batteries may be damaged or catch fire.

 **DANGER**

To avoid leakage, smoke, flammable gas release, thermal runaway, fire, or explosion, do not disassemble, alter, or damage batteries, for example, insert foreign objects into batteries, squeeze batteries, or immerse batteries in water or other liquids.

 **DANGER**

Do not touch battery terminals with other metal objects, which may cause heat or electrolyte leakage.

 **DANGER**

There is a risk of fire or explosion if the model of the battery in use or used for replacement is incorrect. Use a battery of the model recommended by the manufacturer.

 **DANGER**

Battery electrolyte is toxic and volatile. Do not get contact with leaked liquids or inhale gases in the case of battery leakage or odor. In such cases, stay away from the battery and contact professionals immediately. Professionals must wear safety goggles, rubber gloves, gas masks, and protective clothing, power off the equipment, remove the battery, and contact technical engineers.

 **DANGER**

A battery is an enclosed system and will not release any gases under normal operations. If a battery is improperly treated, for example, burnt, needle-pricked, squeezed, struck by lightning, overcharged, or subject to other adverse conditions that may cause battery thermal runaway, the battery may be damaged or an abnormal chemical reaction may occur inside the battery, resulting in electrolyte leakage or production of gases such as CO and H₂. To prevent fire or device corrosion, ensure that flammable gas is properly exhausted.

 **DANGER**

The gas generated by a burning battery may irritate your eyes, skin, and throat. Take protective measures promptly.

 **WARNING**

Install batteries in a dry area. Do not install them under areas prone to water leakage, such as air conditioner vents, ventilation vents, feeder windows of the equipment room, or water pipes. Ensure that no liquid enters the equipment to prevent faults or short circuits.

 **WARNING**

Before installing and commissioning batteries, prepare fire fighting facilities, such as fire sand and carbon dioxide fire extinguishers, according to construction standards and regulations. Before putting into operation, ensure that fire fighting facilities that comply with local laws and regulations are installed.

 **WARNING**

Before unpacking, storage, and transportation, ensure that the packing cases are intact and the batteries are correctly placed according to the labels on the packing cases. Do not place a battery upside down or vertically, lay it on one side, or tilt it. Stack the batteries according to the stacking requirements on the packing cases. Ensure that the batteries do not fall or get damaged. Otherwise, they will need to be scrapped.

 **WARNING**

After unpacking batteries, place them in the required direction. Do not place a battery upside down or vertically, lay it on one side, tilt it, or stack it. Ensure that the batteries do not fall or get damaged. Otherwise, they will need to be scrapped.

 **WARNING**

Tighten the screws on copper bars or cables to the torque specified in this document. Periodically confirm whether the screws are tightened, check for rust, corrosion, or other foreign objects, and clean them up if any. Loose screw connections will result in excessive voltage drops and batteries may catch fire when the current is high.

 **WARNING**

After batteries are discharged, charge them in time to avoid damage due to overdischarge.

Statement

The Company shall not be liable for any battery damage, personal injury, death, property loss, and/or other consequences caused by the following reasons:

- Force majeure such as earthquakes, floods, volcanic eruptions, debris flows, lightning strikes, fires, wars, armed conflicts, typhoons, hurricanes, tornadoes, and other extreme weather conditions
- The battery warranty period has expired. You are advised not to use a battery whose warranty period has expired, as this poses safety risks.
- Actions that do not follow instructions in the user manual or direct advice from the Company, including but not limited to the following scenarios:
 - The onsite equipment operating environment or external power parameters do not meet the environment requirements for normal operation, for example, the actual operating temperature of batteries is too high or too low, or the power grid is unstable and experiences outages frequently.
 - Batteries are dropped or incorrectly operated or connected.
 - Batteries are overdischarged due to delayed acceptance or power-on after battery installation.
 - Battery running parameters are incorrectly set.
 - Different types of batteries, for example, batteries of different brands or rated capacities, are used together without prior approval from the Company.
 - Batteries are frequently overdischarged due to improper battery maintenance.
 - Battery use scenarios are changed without prior approval from the Company.
 - Battery maintenance is not performed according to the instructions in the user manual, for example, failing to check battery terminals regularly.
 - Batteries are not transported, stored, or charged according to the instructions in the user manual.
 - Instructions from the Company are not followed during battery relocation or reinstallation.

General Requirements

NOTICE

To ensure battery safety and battery management accuracy, use batteries provided by the Company. The Company is not responsible for any faults of batteries not provided by it.

- Before installing, operating, and maintaining batteries, read the battery manufacturer's instructions and comply with their requirements. The safety precautions specified in this document are highly important and require special attention. For additional safety precautions, see the instructions provided by the battery manufacturer.

- Use batteries within the specified temperature range. When the ambient temperature of the batteries is lower than the allowed range, do not charge the batteries to prevent internal short circuits caused during low-temperature charging.
- Before unpacking batteries, check whether the packaging is intact. Do not use batteries with damaged packaging. If any damage is found, notify the carrier and manufacturer immediately.
- Install batteries within 24 hours after unpacking. If the batteries cannot be installed in time, put them in the original packaging and place them in a dry indoor environment without corrosive gases. The process from unpacking batteries to powering on the system must be completed within 72 hours. During routine maintenance, ensure that the power-off time does not exceed 24 hours.
- Do not use a damaged battery (such as damage caused when a battery is dropped, bumped, bulged, or dented on the enclosure), because the damage may cause electrolyte leakage or flammable gas release. In the case of electrolyte leakage or structural deformation, contact the installer or professional O&M personnel immediately to remove or replace the battery. Do not store the damaged battery near other devices or flammable materials and keep it away from non-professionals.
- Before working on a battery, ensure that there is no irritant or scorched smell around the battery.
- When installing batteries, do not place installation tools, metal parts, or sundries on the batteries. After the installation is complete, clean up the objects on the batteries and the surrounding area.
- Do not install battery packs on rainy, snowy, or foggy days. Otherwise, the battery packs may be corroded by moisture or rain.
- If batteries are exposed to water accidentally, do not install them. Instead, transport the batteries to a safe isolation point and dispose of them in a timely manner.
- Before installing a battery pack, check that its enclosure is not deformed or damaged.
- Check whether the positive and negative battery terminals are grounded unexpectedly. If so, disconnect the battery terminals from the ground.
- Do not perform welding or grinding work around batteries to prevent fire caused by electric sparks or arcs.
- If batteries are left unused for a long period of time, store and charge them according to the battery requirements.
- Do not charge or discharge batteries by using a device that does not comply with local laws and regulations.
- Keep the battery loop disconnected during installation and maintenance.
- Monitor damaged batteries during storage for signs of smoke, flame, electrolyte leakage, or heat.
- If a battery is faulty, its surface temperature may be high. Do not touch the battery to avoid scalds.
- Do not stand on, lean on, or sit on the top of the equipment.
- In backup power scenarios, do not use the batteries for the following situations:

- Medical devices substantially important to human life
- Control equipment such as trains and elevators, as this may cause personal injury
- Computer systems of social and public importance
- Locations near medical devices
- Other devices similar to those described above

Short-Circuit Protection

- When installing and maintaining batteries, wrap the exposed cable terminals on the batteries with insulation tape.
- Avoid foreign objects (such as conductive objects, screws, and liquids) from entering a battery, as this may cause short circuits.

Leakage Handling

NOTICE

Electrolyte leakage may damage the equipment. It will corrode metal parts and boards, and ultimately damage the boards.

Electrolyte is corrosive and can cause irritation and chemical burns. If you come into direct contact with the battery electrolyte, do as follows:

- Inhalation: Evacuate from contaminated areas, get fresh air immediately, and seek immediate medical attention.
- Eye contact: Immediately wash your eyes with water for at least 15 minutes, do not rub your eyes, and seek immediate medical attention.
- Skin contact: Wash the affected areas immediately with soap and water and seek immediate medical attention.
- Intake: Seek immediate medical attention.

Recycling

- Dispose of waste batteries in accordance with local laws and regulations. Do not dispose of batteries as household waste. Improper disposal of batteries may result in environmental pollution or an explosion.
- If a battery leaks or is damaged, contact technical support or a battery recycling company for disposal.
- If batteries are out of service life, contact a battery recycling company for disposal.
- Do not expose waste batteries to high temperatures or direct sunlight.
- Do not place waste batteries in environments with high humidity or corrosive substances.
- Do not use faulty batteries. Contact a battery recycling company to scrap them as soon as possible to avoid environmental pollution.

2 Overview

2.1 Model Description

Product Models

This document involves the following product models:

- LUNA2000-2.0MWH-4H1
- LUNA2000-2.0MWH-2H1
- LUNA2000-2.0MWH-2H0
- LUNA2000-2.0MWH-HE2H1
- LUNA2000-2.0MWH-HE1H1
- LUNA2000-2.0MWH-1H1
- LUNA2000-2.0MWH-1H0
- LUNA2000-1.0MWH-1H1
- LUNA2000-1.0MWH-ES1H1

Figure 2-1 Model number (LUNA2000-2.0MWH-HE2H1 is used as an example)

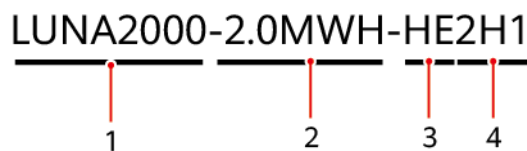

Table 2-1 Model number description

No.	Meaning	Description
1	Product family	LUNA2000: Smart String ESS
2	Capacity level	1.0MWH: nominal capacity ^[1] 2.0MWH: nominal capacity ^[1]

No.	Meaning	Description
3	Region	ES: Spain HE: high-altitude area
4	Backup power	<ul style="list-style-type: none">• 4H1: Applies to scenarios where the backup duration is greater than or equal to 4 hours• 2H0, 2H1: Applies to scenarios where the backup duration is greater than or equal to 2 hours• 1H0, 1H1: Applies to scenarios where the backup duration is greater than or equal to 1 hour

Note [1]: The nominal capacity is on the nameplate.

Model Identification





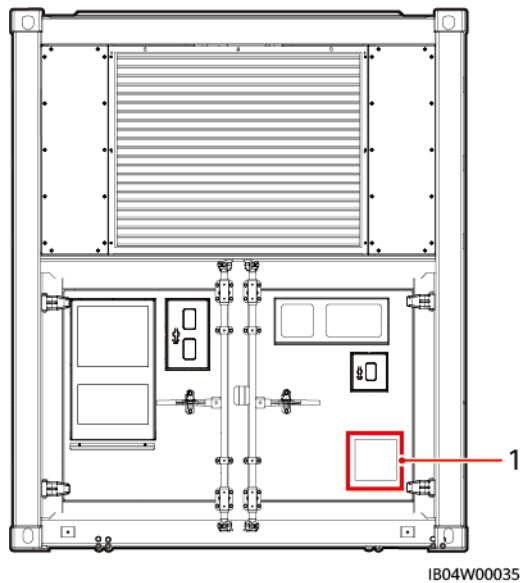

You can view the product model on the nameplate on the side of the container.

Figure 2-2 Position of the nameplate



(1) Position of the nameplate

2.2 Label Description

Label	Name	Meaning
	Electric shock warning	High voltage exists after the equipment is powered on. Only qualified and trained electrical technicians are allowed to operate the equipment.
	Grounding	Indicates the position for connecting the ground cable.
	ADR transportation warning label – diamond-shape label	Helps other traffic participants identify and keep away from hazardous sources in a timely manner to reduce the risk of accidents.
	Scald and heat warning	Indicates high temperature of the equipment to prevent scald.
	Height	The equipment is high. You may need tools such as an insulated stool or ladder to facilitate operations.
	Height (or mind the step) warning	Indicates that the container height is greater than 2.6 m to alert the personnel during transportation and operations.

Label	Name	Meaning
HWLU 000000 0	Container number	Indicates the equipment container number.

2.3 Functions and Features

Functions

The LUNA2000-2.0MWH and 1.0MWH series Smart String ESSs (excluding the Smart PCS) can manage charge and discharge of the DC power rectified by the Smart Power Control System (PCS) for power grid services such as peak shaving and frequency regulation.

LUNA2000C V100R023C00SPC100 and later versions support remote black start in microgrid scenarios.

2.4 Appearance and Layout

NOTE

The ESS has various appearances and layouts. The following figures are for reference only.

Figure 2-3 Appearance



(1) Battery cabin

(2) Smart Rack Controller cabin

(3) Control unit cabin

Figure 2-4 Rear view



(1) Explosion relief panel

(2) Air conditioner

Figure 2-5 Left view

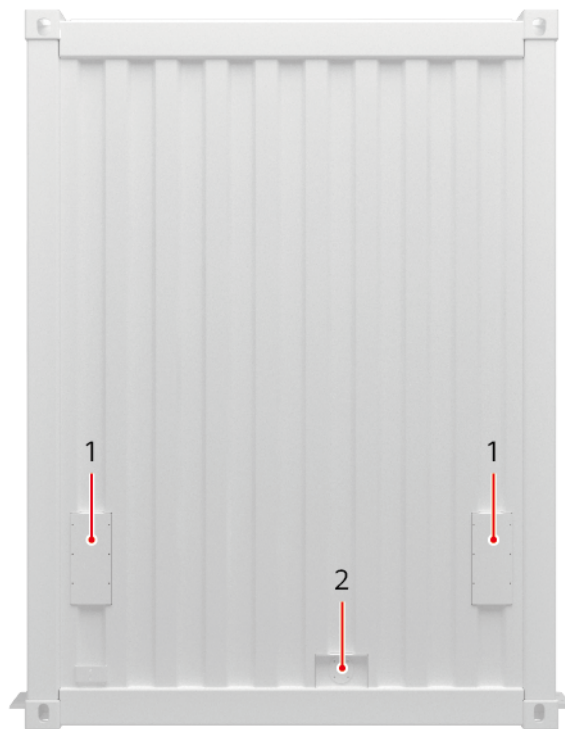

(1) Air intake vent

(2) Water sprinkler port

Figure 2-6 Dimensions

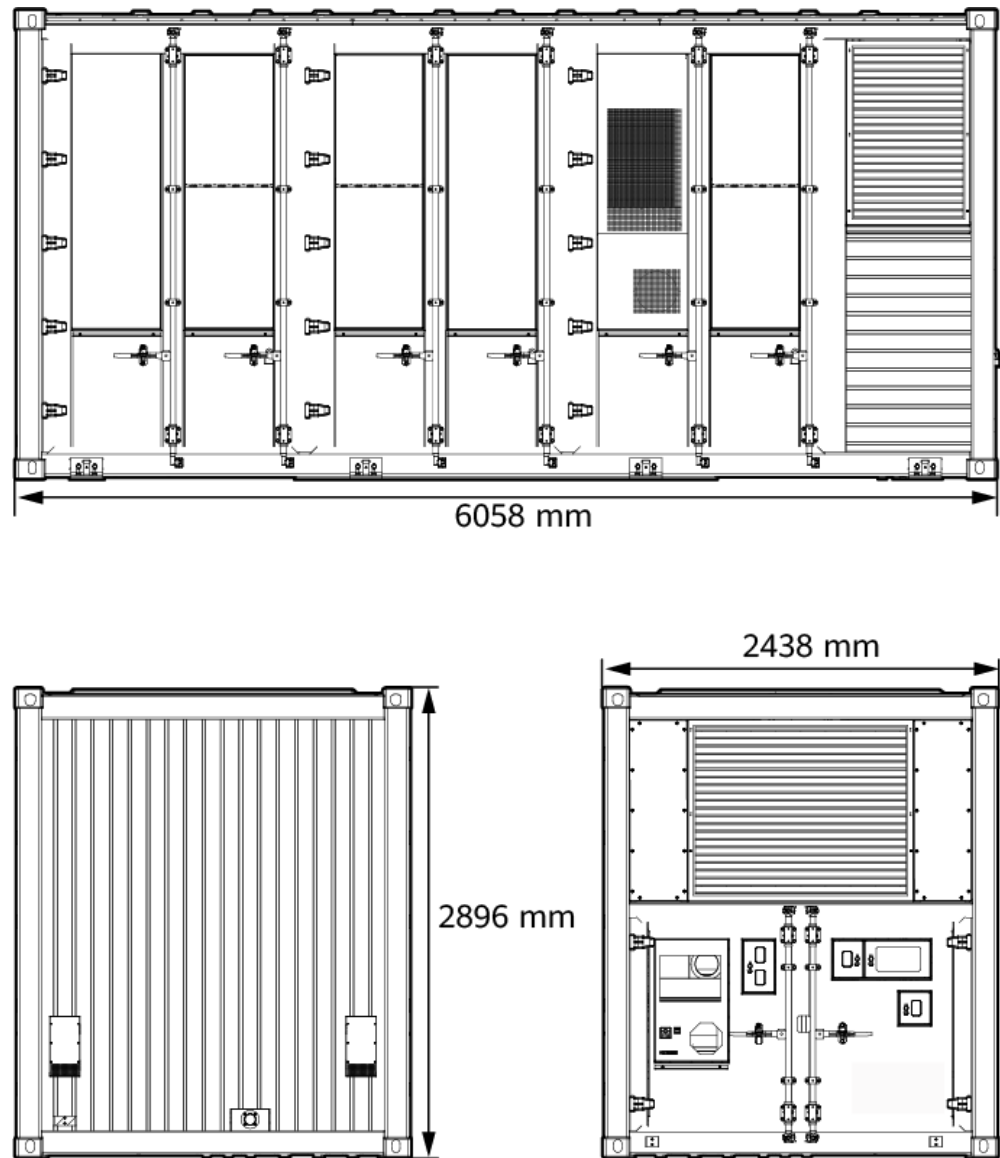

IB04W90102

The number of air conditioners, circuit breakers, and Smart Rack Controllers varies depending on the model. For details, see [Table 2-2](#).

Table 2-2 Layout by model

Model	Number of Air Conditioners in the Battery Cabin	Air Conditioner Position in the Battery Cabin	Number of DC Circuit Breakers in the Control Unit Cabin	Number of Smart Rack Controllers	Number of Exhaust Fans	Number of Mixed-Flow Fans	Number of Explosion Relief Panels¹
LUNA2000-2.0MWH-4H1	2	5/11	3	3	2	10	0 or 6
LUNA2000-2.0MWH-2H1	6	1/3/5/7/9/11	3	3	2	10	0 or 6
LUNA2000-2.0MWH-2H1	4	1/4/7/10	6	3	2	10	0 or 6
LUNA2000-2.0MWH-2H0	6	2/4/6/8/10/12	3	3	2	10	0 or 4
LUNA2000-2.0MWH-HE2H1	4	1/4/7/10	6	3	2	10	0 or 6
LUNA2000-2.0MWH-HE1H1	6	1/3/5/7/9/11	6	6	2	10	0 or 6
LUNA2000-2.0MWH-1H1	6	1/3/5/7/9/11	6	6	2	10	0 or 6
LUNA2000-2.0MWH-1H1	8	1/2/4/5/7/8/10/11	6	6	2	10	0 or 6
LUNA2000-2.0MWH-1H0	8	1/2/4/5/7/8/10/11	6	6	2	10	0 or 6
LUNA2000-1.0MWH-1H1	3	1/5/7	6	3	2	10	0 or 6
LUNA2000-1.0MWH-ES1H1	3	1/5/7	6	3	2	10	0 or 6
Note 1: Some models are equipped with explosion relief panels. The actual products delivered may vary.							

Figure 2-7 Layout of two air conditioners

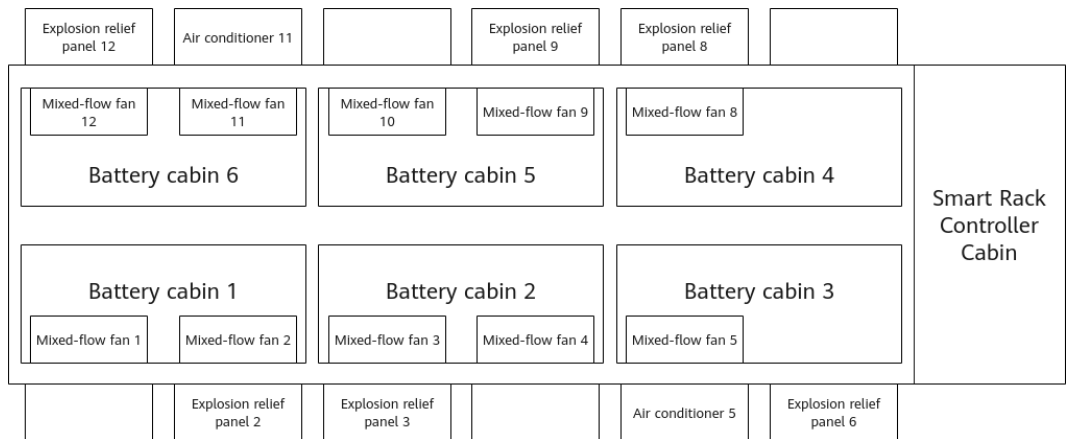

Figure 2-8 Layout of three air conditioners

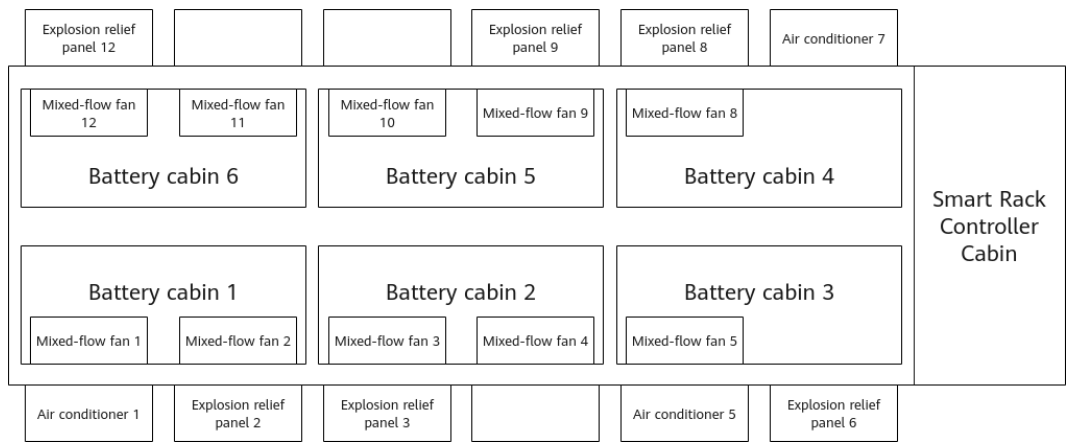

Figure 2-9 Layout of four air conditioners

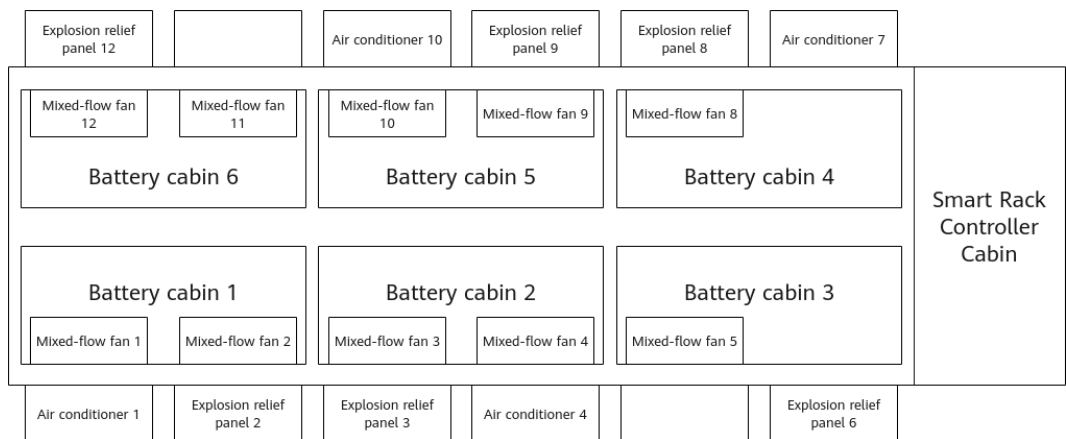

Figure 2-10 Layout of six air conditioners in odd-numbered slots

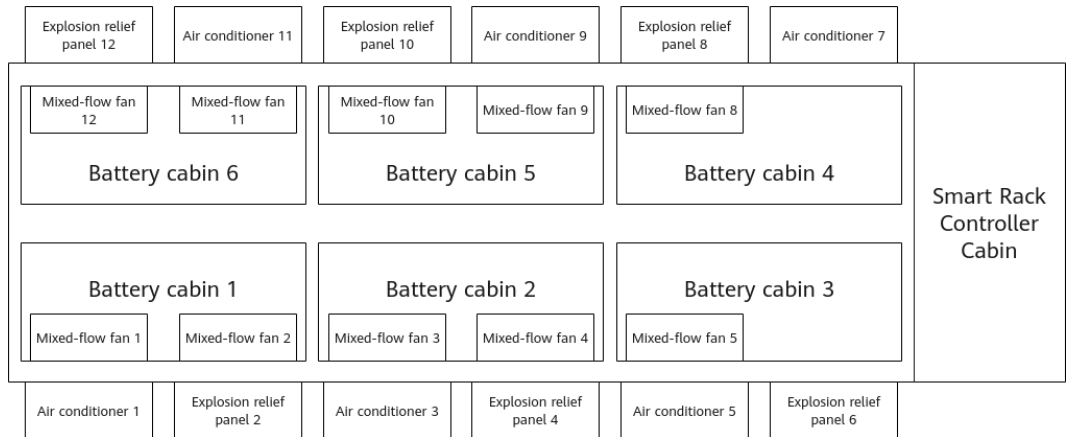

Figure 2-11 Layout of six air conditioners in even-numbered slots

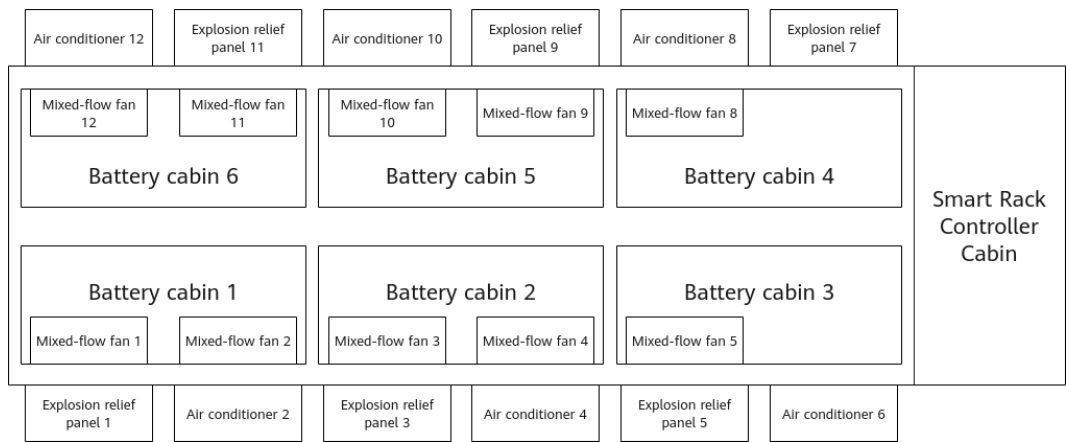
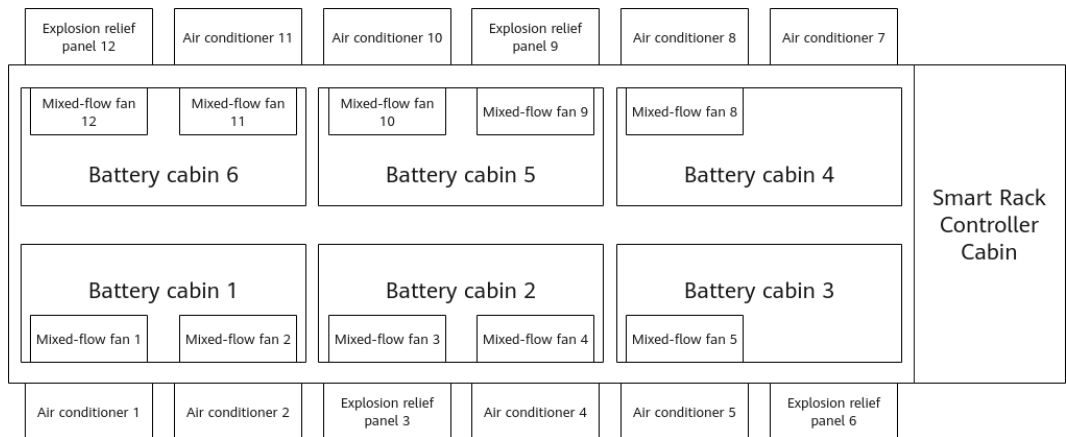

Figure 2-12 Layout of eight air conditioners



2.5 ESS Composition

2.5.1 Battery Cabin

Figure 2-13 Battery cabin components

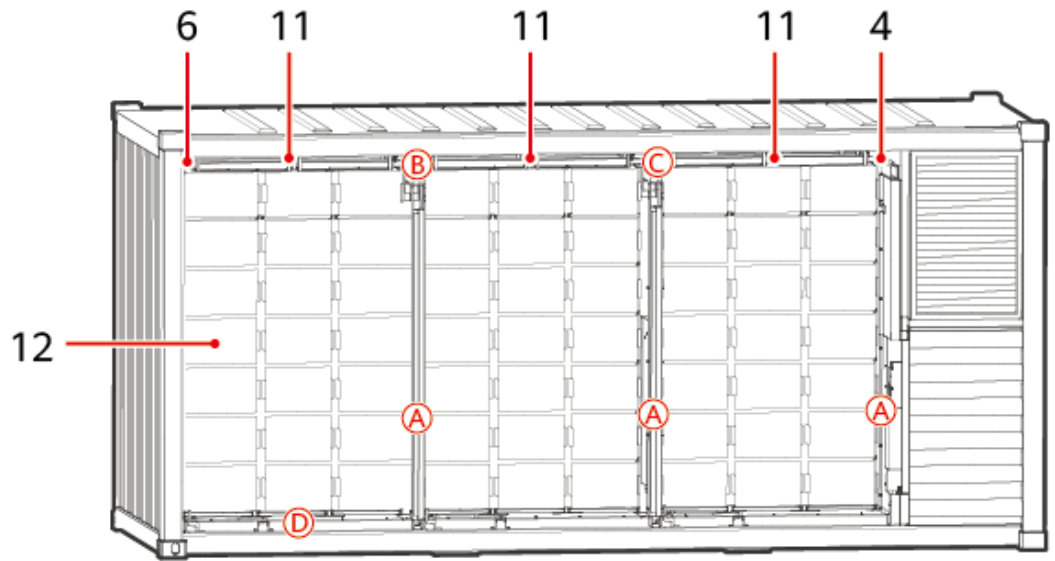

SESSK00001

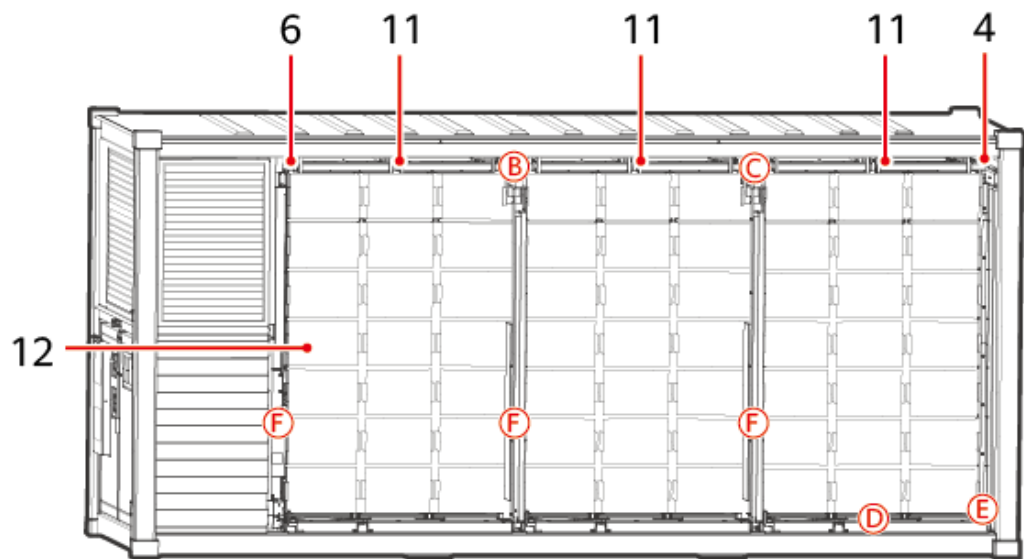

SESSK00001

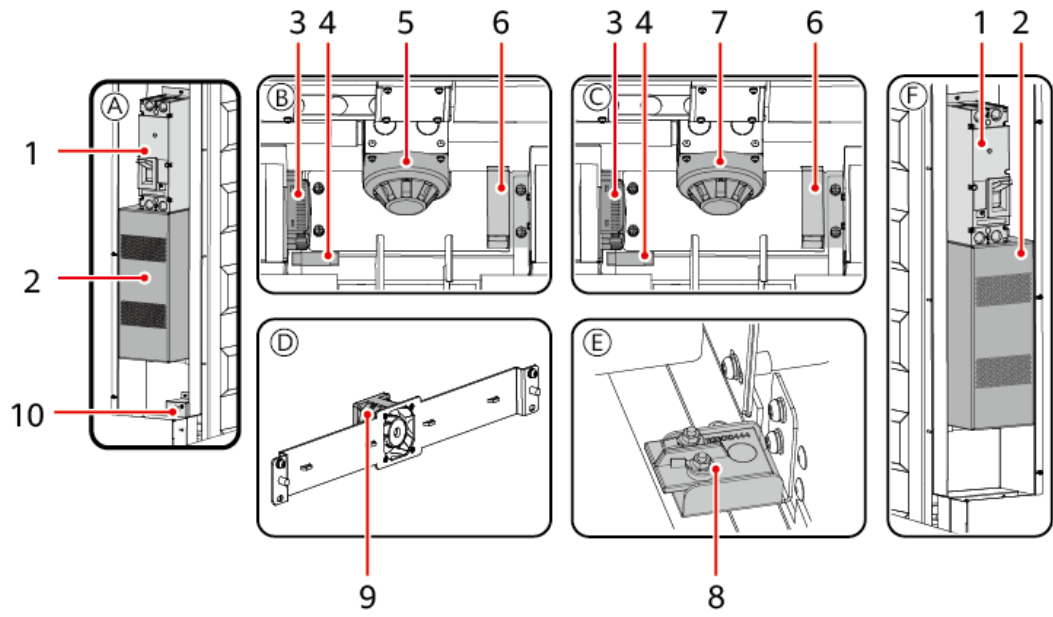







SESSK00001



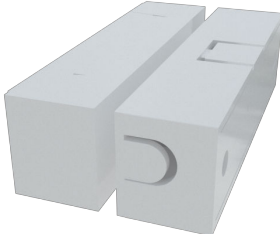

NOTE

The appearance of each component is for reference only, and that of the actual product may vary.

Table 2-3 Description of battery cabin components

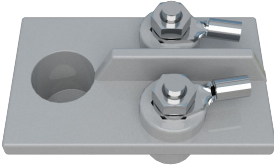
No.	Component	Appearance	Configuration	Quantity Configured for an ESS	Description
1	Circuit breaker		Mandatory	For details, see Table 2-4 .	Provides short-circuit protection and disconnects the high-voltage circuit of the battery rack.
2	Fuse		Mandatory	For details, see Table 2-4 .	Provides short-circuit protection.

No.	Component	Appearance	Configuration	Quantity Configured for an ESS	Description
3	Temperature and humidity (T/H) sensor		Mandatory	For details, see Table 2-4 .	Measures the real-time ambient temperature and humidity in the battery cabin.
4	Door status sensor		Mandatory	6	Monitors the status of the battery cabin door.
5	Smoke detector		Mandatory	2	Common photoelectric smoke detector (voltage output type)
6	CO sensor		Mandatory	For details, see Table 2-4 .	Checks the concentration of CO in combustible gases.
7	Heat detector		Mandatory	2	Monitors the battery cabin temperature.

No.	Component	Appearance	Configuration	Quantity Configured for an ESS	Description
8	Water sensor		Mandatory	1 (only for some models)	Detects water based on the resistance change between both electrodes.
9	Mixed-flow fan		Mandatory	10	Enhances the exhaust effect of the exhaust fan.
10	Black start button		Mandatory	1	Triggers the ESS black start.
11	Light		Optional	6 (only for some models)	Provides lighting inside the battery cabin.

No.	Component	Appearance	Configuration	Quantity Configured for an ESS	Description
12	Battery pack		Mandatory	For details, see Table 2-4 .	The battery pack is a combination of batteries connected in series and output through a pair of positive and negative terminals. Each battery pack is equipped with a pack optimizer and a battery monitoring unit (BMU).

Table 2-4 Number of battery cabin components per ESS

Model	Battery Pack	T/H Sensor	CO Sensor	Circuit Breaker	Fuse
LUNA2000-2.0MWH-4H1	126	4	6	6	6
LUNA2000-2.0MWH-2H1	126	4	6	6	6
LUNA2000-2.0MWH-2H1	126	4	6	6	6
LUNA2000-2.0MWH-2H0	126	4	6	6	6

Model	Battery Pack	T/H Sensor	CO Sensor	Circuit Breaker	Fuse
LUNA2000-2.0MWH-HE2H1	114	4	6	6	6
LUNA2000-2.0MWH-HE1H1	114	4	6	6	12
LUNA2000-2.0MWH-1H1	126	4	6	6	12
LUNA2000-2.0MWH-1H1	126	4	6	6	12
LUNA2000-2.0MWH-1H0	126	4	6	6	12
LUNA2000-1.0MWH-1H1	63	3	3	3	6
LUNA2000-1.0MWH-ES1H1	63	3	3	3	6

2.5.2 Control Unit Cabin

NOTE

The control unit cabin composition varies depending on the ESS model.

Figure 2-14 Exterior of the control unit cabin (the extinguishant release button is separated from the extinguishant abort button)

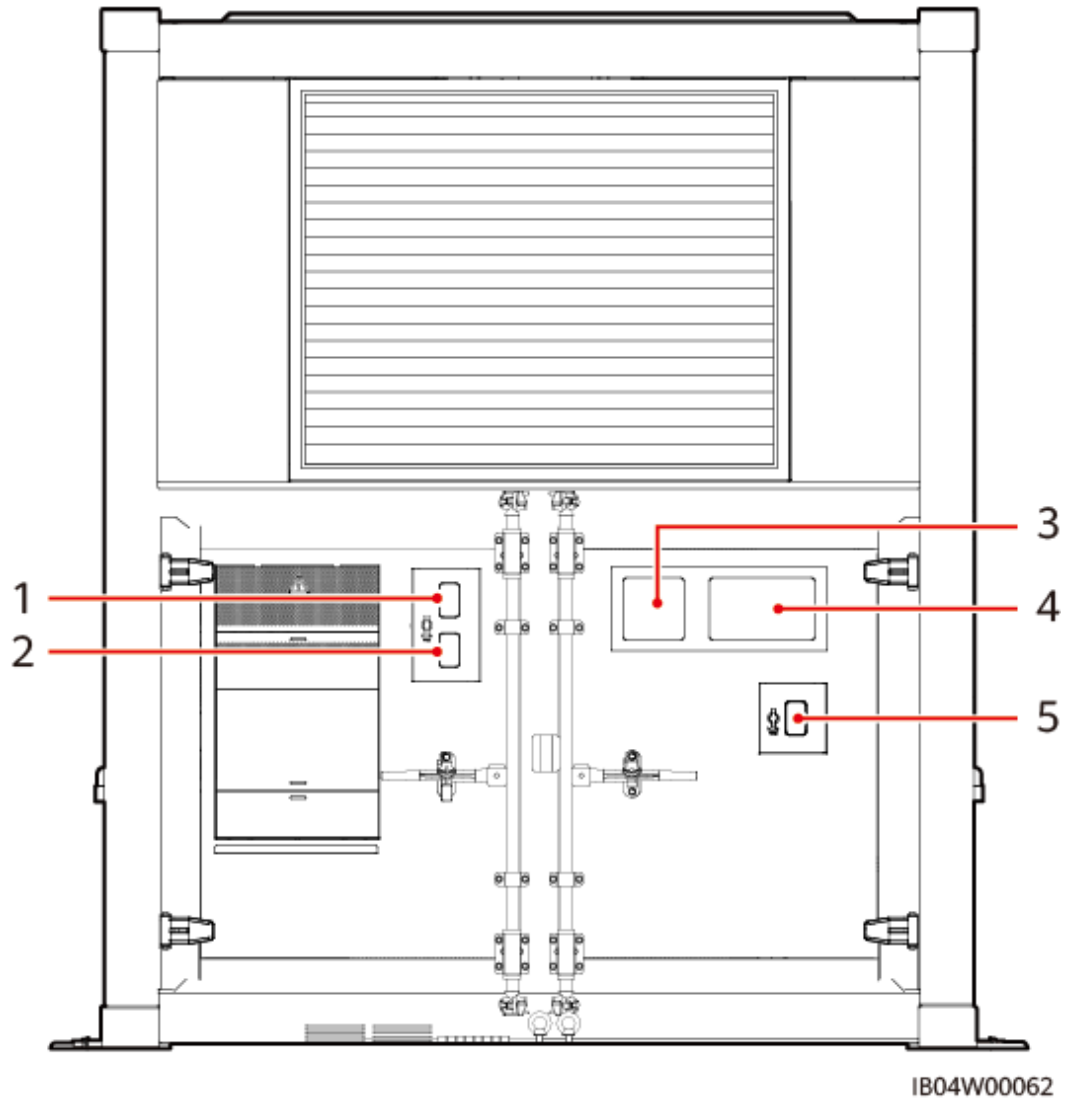

Table 2-5 Description of the control unit cabin exterior (the extinguishant release button is separated from the extinguishant abort button)

No.	Component	Configuration	Quantity Configured for an ESS	Description
1	Extinguishant release button	Mandatory	1	-
2	Extinguishant abort button	Mandatory	1	-

No.	Component	Configuration	Quantity Configured for an ESS	Description
3	Fire alarm horn/strobe	Mandatory	1	Used for audible and visual alarm in the area where an accident occurs.
4	Extinguishant release indicator	Mandatory	1	Used for audible and visual alarm in the extinguishant protection area.
5	ESS abort button	Mandatory	1	-

Figure 2-15 Exterior of the control unit cabin (the extinguishant release button is combined with the extinguishant abort button)

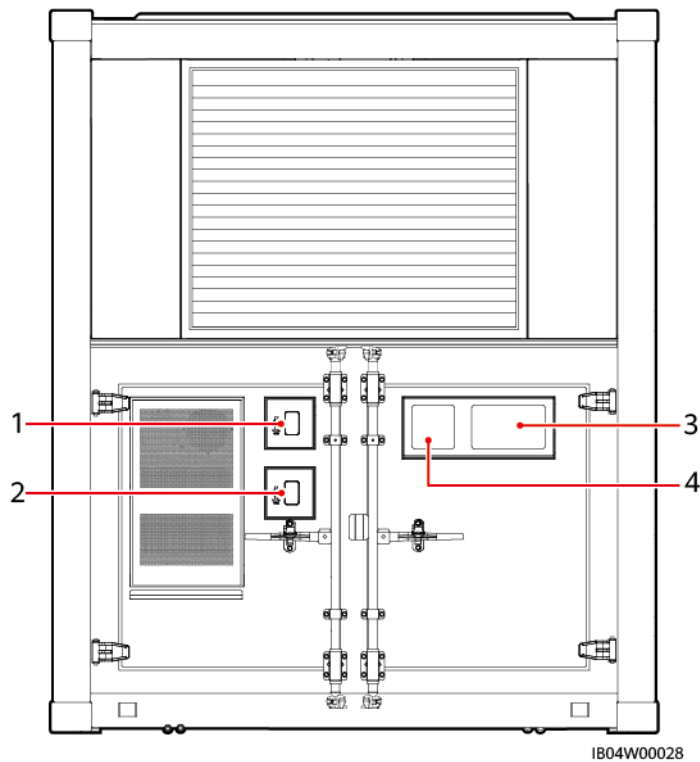

Table 2-6 Description of the control unit cabin exterior (the extinguishant release button is combined with the extinguishant abort button)

No.	Component	Configuration	Quantity Configured for an ESS	Description
1	Extinguishant release/abort button	Mandatory	1	-
2	ESS abort button	Mandatory	1	-
3	Extinguishant release indicator	Mandatory	1	Used for audible and visual alarm in the extinguishant protection area.
4	Fire alarm horn/strobe	Mandatory	1	Used for audible and visual alarm in the area where an accident occurs.

Figure 2-16 Interior of the control unit cabin

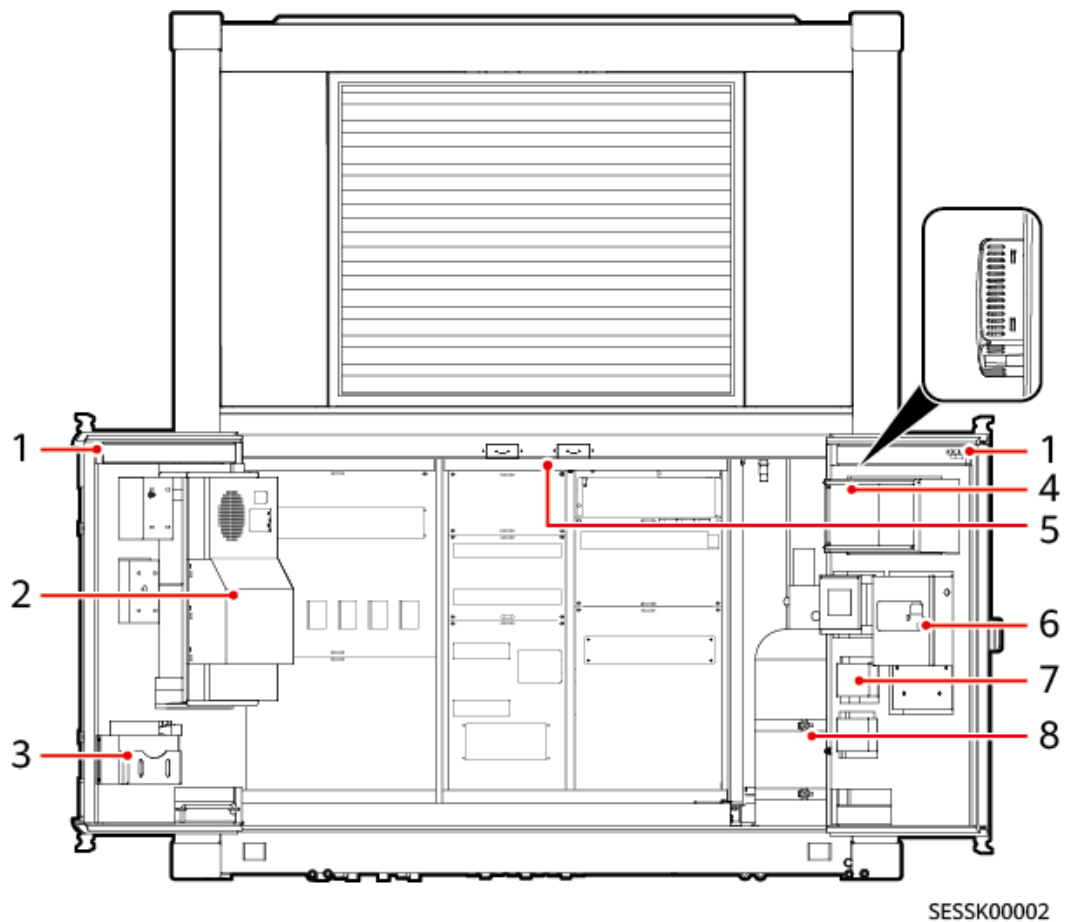

Table 2-7 Description of the control unit cabin interior

No.	Component	Configuration	Quantity Configured for an ESS	Description
1	Door status sensor	Mandatory	2	Monitors the door status of the control unit cabin.
2	Air conditioner in the control unit cabin	Mandatory	1	Dissipates heat for components in the control unit cabin.
3	Document holder	Mandatory	1	Stores documents delivered with the equipment.
4	T/H sensor	Mandatory	1	Measures the real-time ambient temperature and humidity in the control unit cabin.
5	Light	Mandatory	1	Provides lighting in the control unit cabin.
6	Extinguishant control panel	Mandatory	1	Used for fire alarms and automatic fire suppression control. For details, see the extinguishant control panel manual delivered with the ESS.
7	Exhaust controller	Mandatory	2	Controls exhaust fans.
8	Fire cylinder	Mandatory	1	Stores fire extinguishant and is used together with related components, including solenoid valves, pressure gauges, and pipes.

 **NOTE**

The power distribution cabinet in the control unit cabin has various layouts. The following figures are for reference only.

Figure 2-17 Power distribution cabinet in the control unit cabin of LUNA2000-2.0MWH-4H1

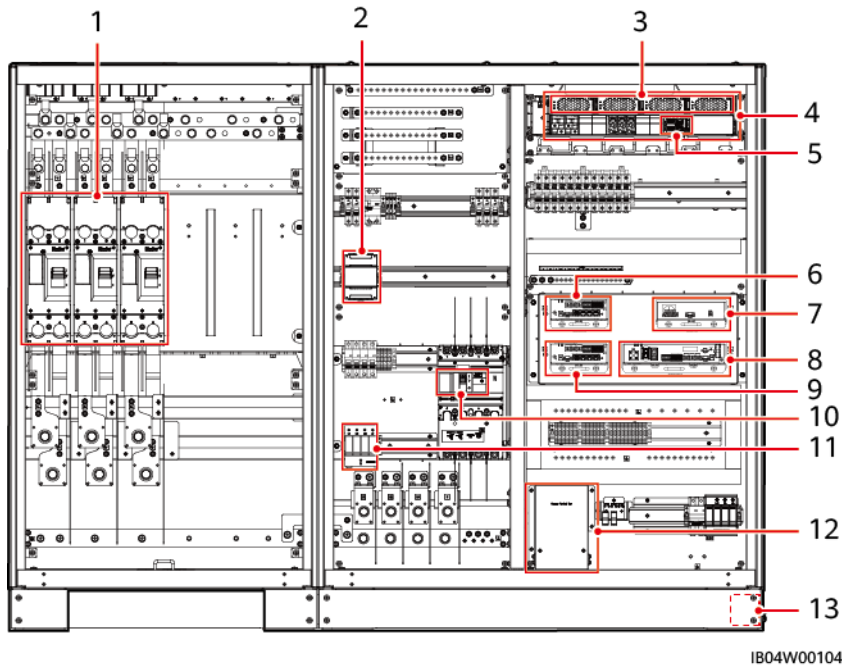

Figure 2-18 Power distribution cabinet in the control unit cabin of LUNA2000-2.0MWH-2H1/LUNA2000-2.0MWH-2H0 (six air conditioners)

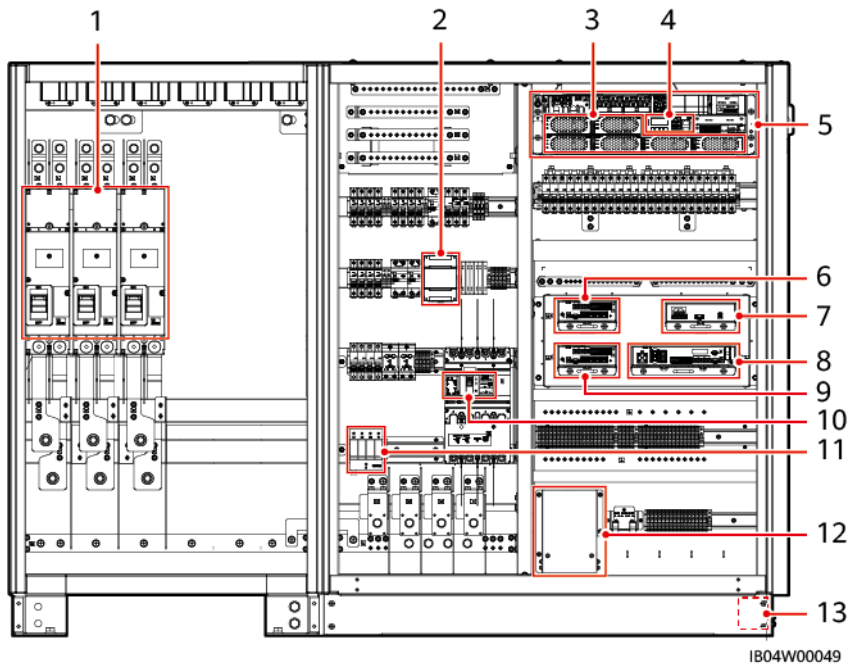

Figure 2-19 Power distribution cabinet in the control unit cabin of LUNA2000-2.0MWH-2H1/LUNA2000-2.0MWH-HE2H1 (four air conditioners)

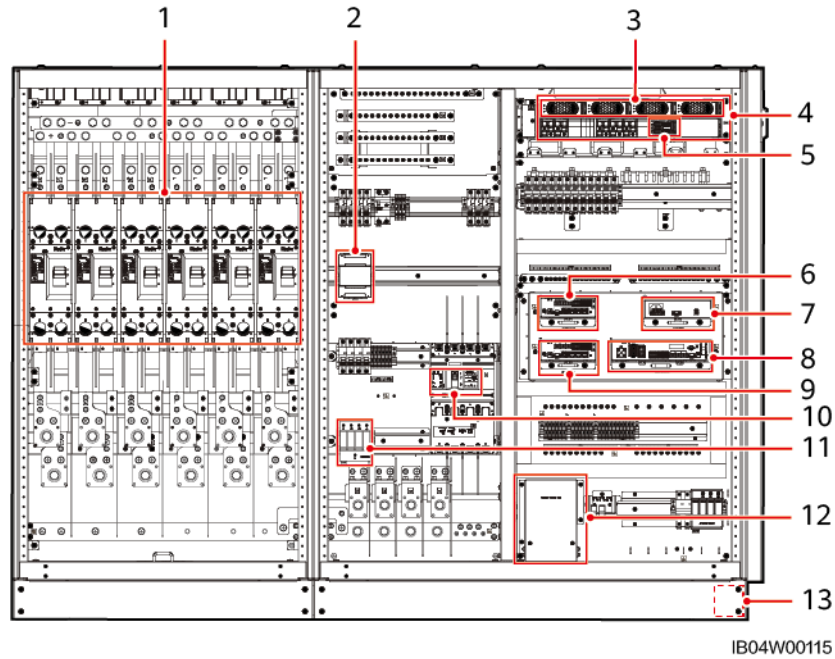

Figure 2-20 Power distribution cabinet in the control unit cabin of LUNA2000-2.0MWH-1H1/LUNA2000-2.0MWH-HE1H1/LUNA2000-2.0MWH-1H0

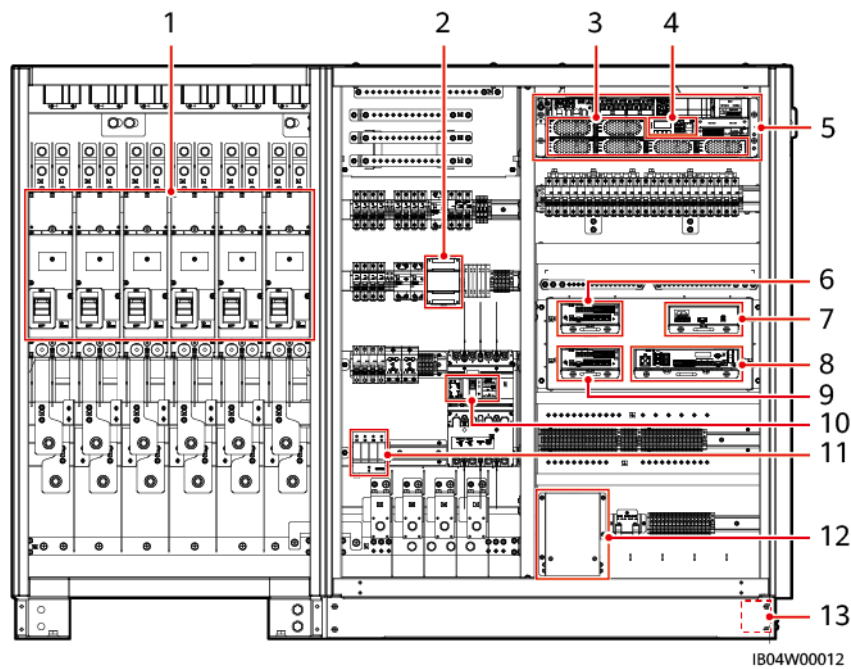
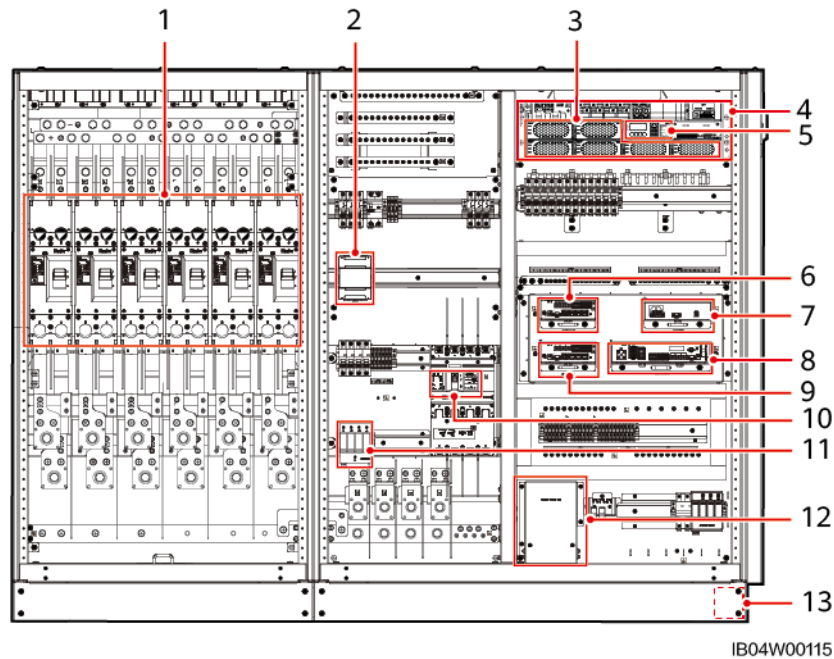

Figure 2-21 Power distribution cabinet in the control unit cabin of LUNA2000-1.0MWH-ES1H1/LUNA2000-1.0MWH-H1



IB04W00115

Table 2-8 Components of the power distribution cabinet in the control unit cabin

N o.	Compon ent	Confi gur ation	Quantity Configured for an ESS	Description
1	DC circuit breaker	Mand atory	For details, see Table 2-9 .	Provides short-circuit protection and DC circuit disconnection.
2	AC meter	Mand atory	1	Collects information about the auxiliary AC input power supply.
3	Power supply unit (PSU)	Mand atory	For details, see Table 2-9 .	Converts AC input power into stable DC power.
4	Monitorin g module (SMU)	Mand atory	1	Collects PSU information and controls PSU output.
5	Embedde d power subrack	Mand atory	1	Provides installation positions for components.
6	SmartMo dule	Optio nal	1	Aggregates interfaces, converts protocols, and collects data for devices in the ESS, and provides additional ports for the CMU.

No.	Component	Configuration	Quantity Configured for an ESS	Description
7	Adapter	Mandatory	1	Supplies power to the CMU and SmartModule of the ESS.
8	Central Monitoring Unit (CMU)	Mandatory	1	Aggregates interfaces, converts protocols, collects, stores, and monitors data, and performs unified monitoring and local maintenance for devices in the ESS.
9	Smart-Module	Mandatory	1	Aggregates interfaces, converts protocols, and collects data for devices in the ESS, and provides additional ports for the CMU.
10	AC circuit breaker	Mandatory	1	Provides short-circuit protection and disconnects the auxiliary power supply circuit of the ESS.
11	AC surge protective device (SPD)	Mandatory	1	Provides AC surge protection.
12	Fiber management tray	Mandatory	1	Holds optical fibers.
13	Water sensor	Mandatory	1	Detects water based on the resistance change between both electrodes.

Table 2-9 Configurations of components in the power distribution cabinet per ESS

ESS Model	Number of Air Conditioners in the Battery Cabin	Air Conditioner Position in the Battery Cabin	Number of DC Circuit Breakers in the Control Unit Cabin	SMU Model	Number of PSUs	Subrack Type
LUNA2000-2.0MWH-4H1	2	5/11	3	SMU 11B	4	ETP48200-B2A1
LUNA2000-2.0MWH-2H1	6	1/3/5/7/9/11	3	SMU 02C	6	ETP48400-C3B1

ESS Model	Number of Air Conditioners in the Battery Cabin	Air Conditioner Position in the Battery Cabin	Number of DC Circuit Breakers in the Control Unit Cabin	SMU Model	Number of PSUs	Subrack Type
LUNA2000-2.0MWH-2H1	4	1/4/7/10	6	SMU 11B	4	ETP48200-B2A1
LUNA2000-2.0MWH-2H0	6	2/4/6/8/10/12	3	SMU 02C	6	ETP48400-C3B1
LUNA2000-2.0MWH-HE2H1	4	1/4/7/10	6	SMU 11B	4	ETP48200-B2A1
LUNA2000-2.0MWH-HE1H1	6	1/3/5/7/9/11	6	SMU 02C	6	ETP48400-C3B1
LUNA2000-2.0MWH-1H1	6	1/3/5/7/9/11	6	SMU 02C	6	ETP48400-C3B1
LUNA2000-2.0MWH-1H1	8	1/2/4/5/7/8/10/11	6	SMU 02C	6	ETP48400-C3B1
LUNA2000-2.0MWH-1H0	8	1/2/4/5/7/8/10/11	6	SMU 02C	6	ETP48400-C3B1
LUNA2000-1.0MWH-1H1	3	1/5/7	6	SMU 02C	6	ETP48400-C3B1
LUNA2000-1.0MWH-ES1H1	3	1/5/7	6	SMU 02C	6	ETP48400-C3B1

2.5.3 Smart Rack Controller Cabin

Figure 2-22 Components in the Smart Rack Controller cabin (six Smart Rack Controllers)

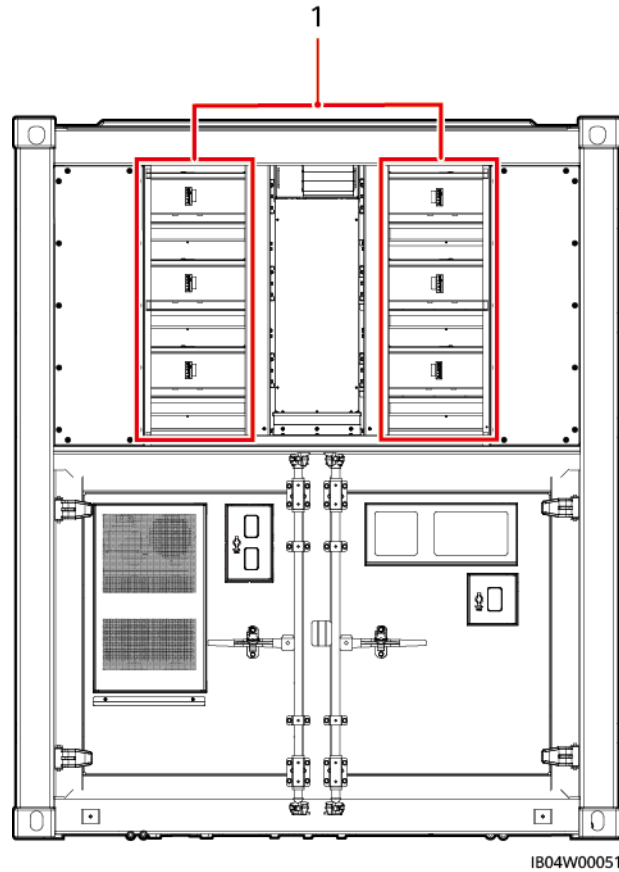
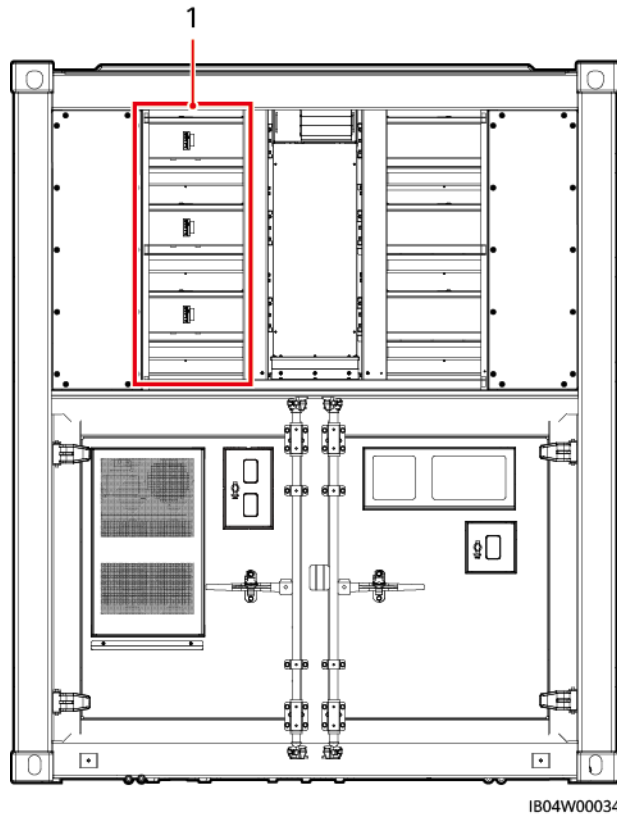

Figure 2-23 Components in the Smart Rack Controller cabin (three Smart Rack Controllers)



IB04W00034

Table 2-10 Description of components in the Smart Rack Controller cabin

No.	Component	Configuration	Quantity Configured for an ESS	Description
1	Smart Rack Controller	Mandatory	<ul style="list-style-type: none"> • LUNA2000-2.0MWH-4 H1: 3 • LUNA2000-2.0MWH-2 H1: 3 • LUNA2000-2.0MWH-2 H0: 3 • LUNA2000-2.0MWH-HE2H1: 3 • LUNA2000-2.0MWH-HE1H1: 6 • LUNA2000-2.0MWH-1 H1: 6 • LUNA2000-2.0MWH-1 H0: 6 • LUNA2000-1.0MWH-1 H1: 3 • LUNA2000-1.0MWH-ES1H1: 3 	Manages charge and discharge of the battery rack.
2	Exhaust module	Mandatory	1	Includes fan modules (two exhaust fans) and air filter sponge.

2.6 Components

2.6.1 Power Supply and Distribution System

2.6.1.1 Battery Pack

The battery pack is a combination of batteries connected in series and output through a pair of positive and negative terminals. Each battery pack is equipped with a pack optimizer and a battery monitoring unit (BMU).

 **NOTE**

The appearance of the battery pack is for reference only, and that of the actual product may vary.

Figure 2-24 Appearance

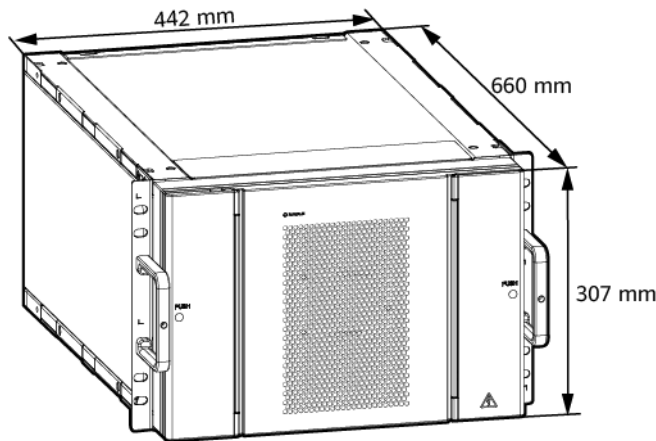

IB04H00010

Technical Specifications	ESM51320AS1	ESM57280AS1	ESM57280AS5
Cell material	Lithium iron phosphate	Lithium iron phosphate	Lithium iron phosphate
Cell capacity	3.2 V/320 Ah	3.2 V/280 Ah	3.2 V/280 Ah
Battery configuration	16S1P	18S1P	18S1P
Rated voltage	51.2 V	57.6 V	57.6 V
Nominal energy	16.38 kWh	16.128 kWh	16.128 kWh
Charge/Discharge rate	≤ 1C	0.5C or ≤ 1C	0.5C
Net weight	≤ 140 kg	≤ 140 kg	≤ 140 kg
Dimensions (H x W x D)	307 mm x 442 mm x 660 mm	307 mm x 442 mm x 660 mm	307 mm x 442 mm x 660 mm
Cooling mode	Air cooling	Air cooling	Air cooling
IP rating	IP20	IP20	IP20
Storage temperature	-40°C to +60°C	-40°C to +60°C	-40°C to +60°C
Transportation temperature	-40°C to +60°C	-40°C to +60°C	-40°C to +60°C

Technical Specifications	ESM51320AS1	ESM57280AS1	ESM57280AS5
Equalization mode	Passive cell balancing	Passive cell balancing	Passive cell balancing
Communications port	CAN 2.0	CAN 2.0	CAN 2.0

2.6.1.2 Smart Rack Controller

Figure 2-25 Appearance

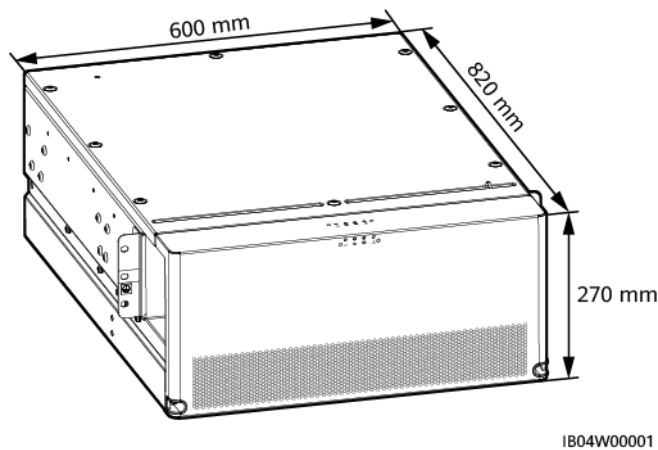

Table 2-11 Efficiency

Technical Specifications	Smart Rack Controller
Maximum efficiency	≥ 99.0%

Table 2-12 Battery side

Technical Specifications	Smart Rack Controller
Number of battery racks	2
Minimum startup voltage	350 V
Rated power per rack	172 kW
Rated power per Smart Rack Controller	344 kW

Table 2-13 Bus side

Technical Specifications	Smart Rack Controller
Number of battery racks connected to the bus	2
Maximum DC voltage	1500 V
Rated operating voltage	1200 V
Rated operating current per rack	143.3 A

Table 2-14 General specifications

Technical Specifications	Smart Rack Controller
Parallel mode	Two parallel Smart Rack Controllers on the battery side and two on the bus side
Overtoltage category	Bus side DC II
Dimensions (H x W x D)	270 mm x 600 mm x 820 mm
Net weight	≤ 90 kg
IP rating	IP66
DC surge protection on the bus side	Type II
Operating temperature range	-30°C to +60°C
Operating humidity range	0%–100% (non-condensing)
Storage temperature	-40°C to +70°C
Storage humidity	5%–95% RH
Cooling mode	Smart air cooling
Maximum operating altitude	4000 m
Communications port	CAN, RS485, FE

2.6.1.3 Embedded Power Subrack

ESS Model	Air Conditioner Position in the Battery Cabin	Subrack Model	PSU
LUNA2000-2.0MWH-4H1	5/11	ETP48200-B2A1	R4830G1

ESS Model	Air Conditioner Position in the Battery Cabin	Subrack Model	PSU
LUNA2000-2.0M WH-2H1	1/3/5/7/9/11	ETP48400-C3B1	R4875G5
LUNA2000-2.0M WH-2H1	1/4/7/10	ETP48200-B2A1	R4830G1
LUNA2000-2.0M WH-2H0	2/4/6/8/10/12	ETP48400-C3B1	R4875G5
LUNA2000-2.0M WH-HE2H1	1/4/7/10	ETP48200-B2A1	R4830G1
LUNA2000-2.0M WH-HE1H1	1/3/5/7/9/11	ETP48400-C3B1	R4875G5
LUNA2000-2.0M WH-1H1	1/3/5/7/9/11	ETP48400-C3B1	R4875G5
LUNA2000-2.0M WH-1H1	1/2/4/5/7/8/10/11	ETP48400-C3B1	R4875G5
LUNA2000-2.0M WH-1H0	1/2/4/5/7/8/10/11	ETP48400-C3B1	R4875G5
LUNA2000-1.0M WH-1H1	1/5/7	ETP48400-C3B1	R4875G5
LUNA2000-1.0M WH-ES1H1	1/5/7	ETP48400-C3B1	R4875G5

ETP48400-C3B1

The embedded power subrack (ETP48400-C3B1) is an embedded power system that converts AC power into DC power. It supplies DC constant voltage to the equipment.

Figure 2-26 Appearance

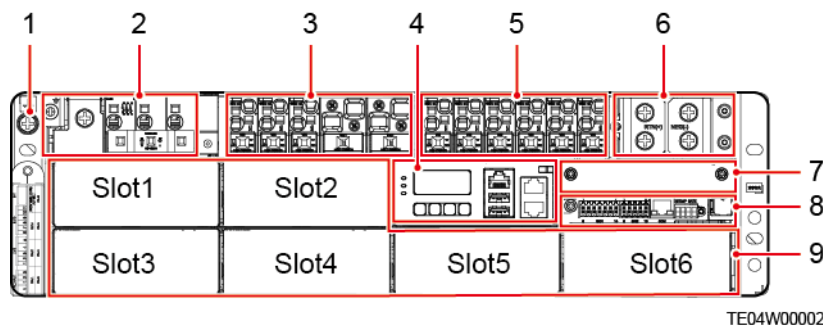

- (1) Ground screw
- (2) AC input module
- (3) LLVD power distribution

- (4) Monitoring module (SMU02C)
- (5) BLVD power distribution
- (6) Battery wiring port
- (7) Reserved slot for the communications expansion module CIM02C or NIM01C3
- (8) User interface module UIM05B1
- (9) Space for PSUs

Technical Specifications	Embedded Power Subrack
AC input system	Three-phase 380 V/400 V AC; 3W + N + PE; 50 Hz/60 Hz

ETP48200-B2A1

The embedded power subrack (ETP48200-B2A1) provides installation positions for components.

Figure 2-27 Appearance

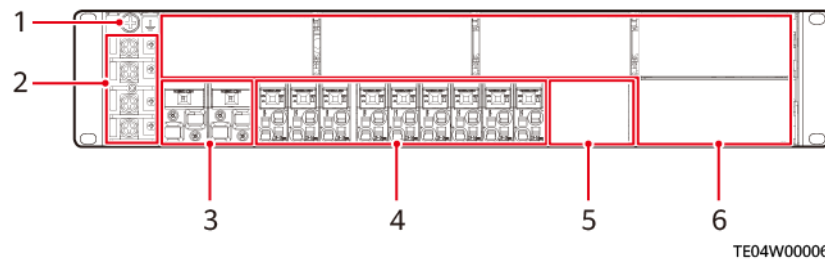

- (1) Ground screw
- (2) Input terminal
- (3) Battery switches
- (4) Load switches
- (5) Monitoring module (SMU11B)
- (6) PSU installation positions

2.6.1.4 PSU

The PSU (R4875G5/R4830G1) converts AC input power into stable DC power.

Appearance

Figure 2-28 Appearance

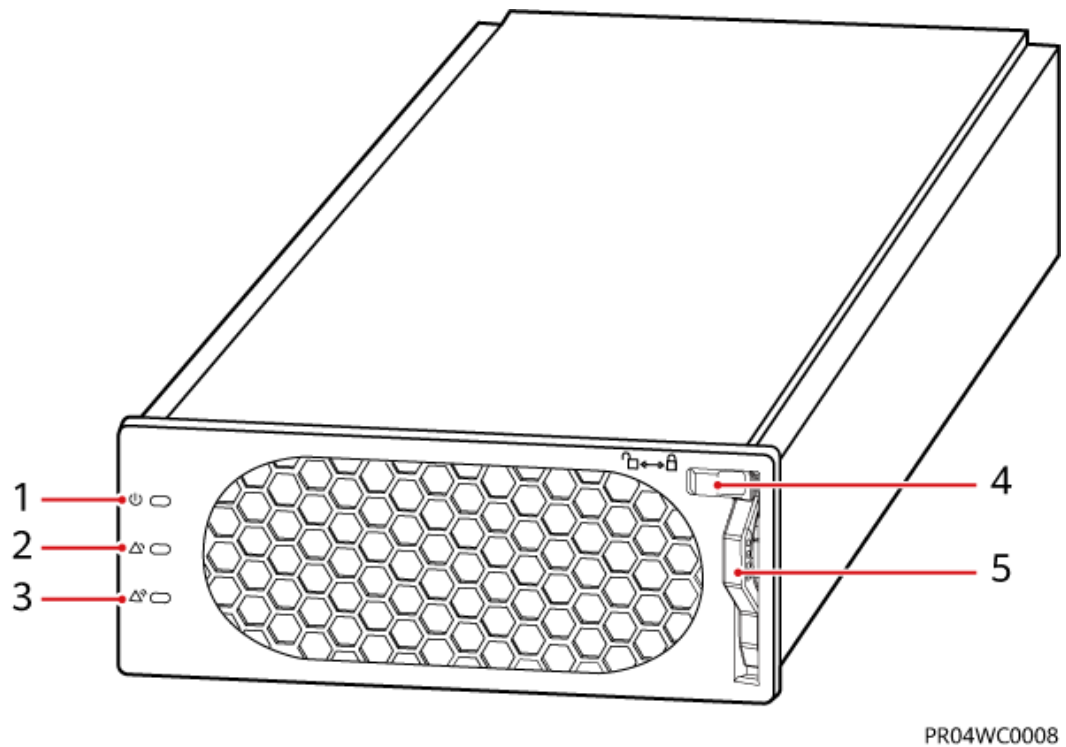

- | | | |
|---------------------|---------------------|---------------------|
| (1) Power indicator | (2) Alarm indicator | (3) Fault indicator |
| (4) Locking latch | (5) Handle | - |

Indicators

Table 2-15 Indicator description

Indicator	Color	Status	Description
Power indicator	Green	Steady on	The PSU has an AC input.
		Off	There is no AC input.
		Blinking at 0.5 Hz	The PSU is damaged.
		Blinking at 4 Hz	Querying is in progress.
Alarm indicator	Yellow	Off	The PSU is loading the application program.
			The PSU does not generate any protection alarm.

Indicator	Color	Status	Description
		Steady on	<ul style="list-style-type: none"> A warning is generated due to ambient overtemperature. A shutdown protection alarm is generated due to ambient overtemperature or undertemperature.
			AC input overvoltage or undervoltage protection is triggered.
		The PSU is hibernating.	
Fault indicator	Red	Blinking at 0.5 Hz	The communication between the PSU and the external equipment is interrupted.
		Off	The PSU is normal.
		Steady on	The PSU locks out due to output overvoltage. The PSU has no output due to an internal fault.

2.6.1.5 SMU

SMU collects PSU information and controls PSU output.

SMU02C

Figure 2-29 Appearance

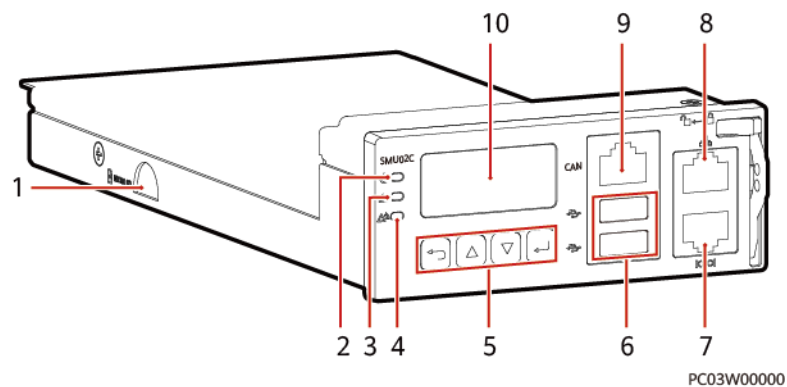







- | | | |
|-------------------------------------|----------------------------|---|
| (1) SD card slot | (2) Running indicator | (3) Minor alarm indicator |
| (4) Major alarm indicator | (5) Buttons | (6) USB port (protected by a security protection mechanism) |
| (7) RS485/RS232 communications port | (8) FE communications port | (9) CAN communications port |







(10) Liquid crystal display (LCD) - -

Table 2-16 Indicator description

Indicator	Color	Status	Description
Running indicator	Green	Off	The SMU is faulty or has no DC input.
		Blinking slowly (0.5 Hz)	The SMU is running properly and communicating with the host properly.
		Blinking fast (4 Hz)	The SMU is running properly but fails to communicate with the host.
Minor alarm indicator	Yellow	Off	No minor alarm or warning is generated.
		Steady on	A minor alarm or warning is generated.
Major alarm indicator	Red	Off	No critical or major alarm is generated.
		Steady on	A critical or major alarm is generated.

Table 2-17 Button description

Button	Name	Description
	Up	Press  or  to scroll through the menus or to change the value of a parameter.
	Down	
	Cancel	Returns to the previous menu without saving the settings.
	Enter	<ul style="list-style-type: none"> Enters the main menu from the standby screen. Enters a submenu from the main menu. Saves menu settings on a submenu.

Button	Name	Description
<p>Note:</p> <ul style="list-style-type: none"> The LCD screen becomes dark if no button is pressed within 30s. You need to log in again if no button is pressed within 1 minute. To increase or decrease a parameter value quickly, press and hold  or . Press and hold  and  for 10s to restart the SMU. Press and hold  and  (or ) for 2s to increase (or decrease) the LCD contrast. 		

The LCD supports two-level password management for different users.

Table 2-18 Two-level password management

Level	Operation Permission	Password
Engineer	All permissions except for changing the administrator password and resetting the web password	000001
Administrator	All permissions	012589 ^a
<p>Note a: The administrator password can be used only by administrators. Do not provide the password to third-party maintenance personnel.</p>		

SMU11B

Figure 2-30 Appearance

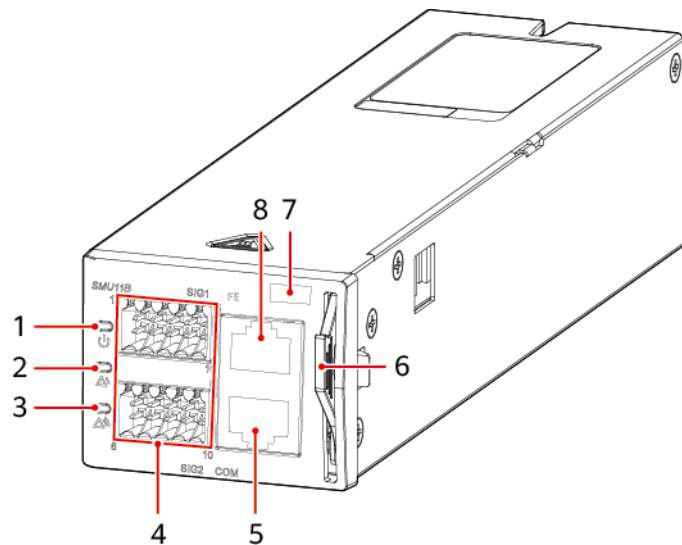

TM10I20150

- | | | |
|-----------------------|----------------------------|---------------------------|
| (1) Running indicator | (2) Minor alarm indicator | (3) Major alarm indicator |
| (4) Wiring terminals | (5) COM port | (6) Handle |
| (7) SN label | (8) FE communications port | - |

Table 2-19 Indicator description

Indicator	Color	Status	Description
Running indicator	Green	Off	The SMU is faulty or has no power input.
		Blinking slowly (0.5 Hz)	The SMU is running properly and communicating with the host properly.
		Blinking fast (4 Hz)	The SMU is running properly but fails to communicate with the host.
Minor alarm indicator	Yellow	Off	No minor alarm or warning is generated.
		Steady on	A minor alarm or warning is generated.
Major alarm indicator	Red	Off	No critical or major alarm is generated.
		Steady on	A critical or major alarm is generated.

2.6.2 Monitoring System

2.6.2.1 CMU

Appearance

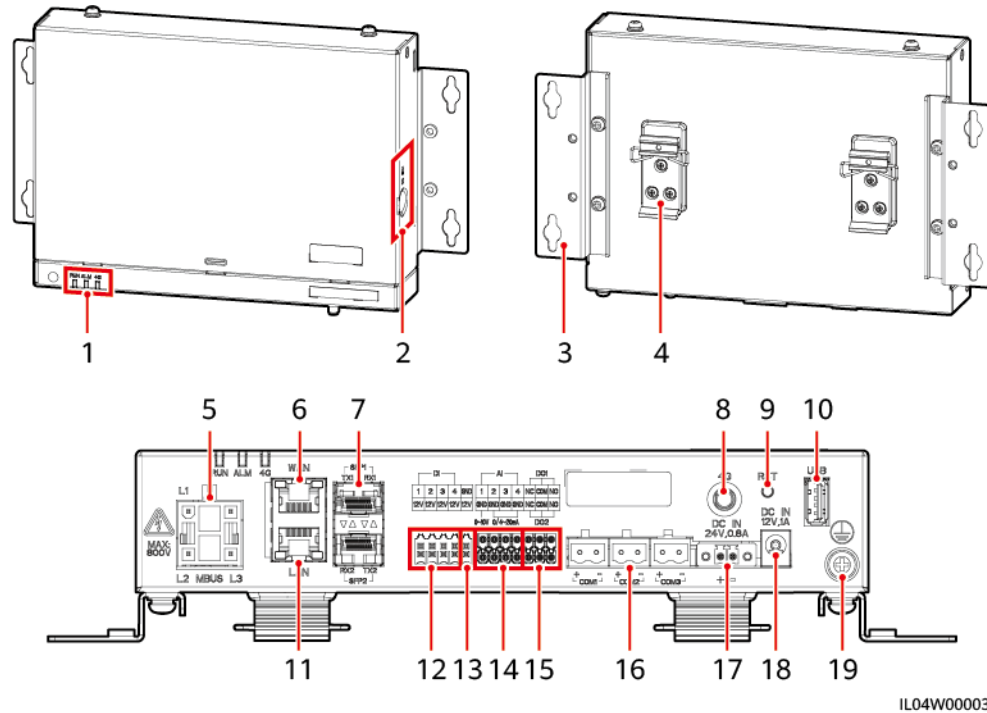

Figure 2-31 Appearance



IL04W00003

- | | | |
|--------------------------------|--------------------------------|----------------------------|
| (1) LED indicators | (2) SIM card slot | (3) Mounting ear |
| (4) Guide rail clamp | (5) MBUS port (reserved) | (6) GE port (WAN) |
| (7) SFP port | (8) 4G antenna port (reserved) | (9) RST button |
| (10) USB port | (11) GE port (LAN) | (12) DI port |
| (13) 12 V output power port | (14) AI port | (15) DO port |
| (16) COM port | (17) 24 V input power port | (18) 12 V input power port |
| (19) Protective earthing point | - | - |

Indicators

Indicator	Status	Description	
Running indicator (RUN) 	Green off	Not powered on	
	Blinking green slowly (on for 1s and then off for 1s)	The communication with the management system is normal.	
	Blinking green fast (on for 0.125s and then off for 0.125s)	The communication with the management system is interrupted.	
Alarm/Maintenance indicator (ALM) 	Alarm status	Red off	No system alarm is generated.
		Blinking red slowly (on for 1s and then off for 4s)	The system raises a warning.
		Blinking red fast (on for 0.5s and then off for 0.5s)	The system raises a minor alarm.
		Steady red	The system raises a major alarm.
	Maintenance status	Green off	No local maintenance is in progress.
		Blinking green slowly (on for 1s and then off for 1s)	Local maintenance is in progress.
		Blinking green fast (on for 0.125s and then off for 0.125s)	Local maintenance fails or the connection to the app is to be set up.
		Steady green	Local maintenance succeeded.

2.6.2.2 SmartModule

Appearance

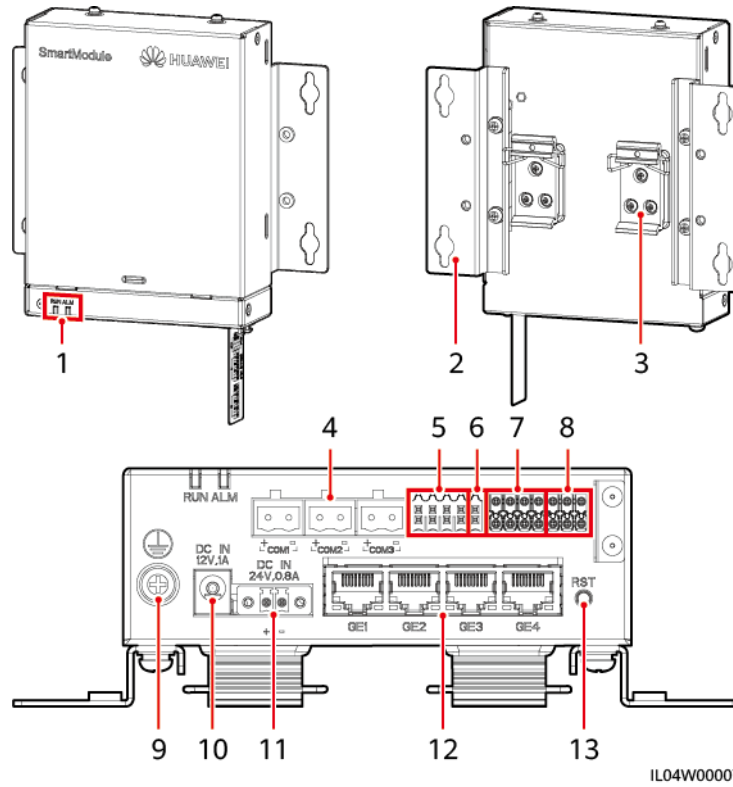

Figure 2-32 Appearance



- | | | |
|----------------------------|----------------------------|-----------------------------|
| (1) LED indicator | (2) Mounting ear | (3) Guide rail clamp |
| (4) COM port | (5) DI port | (6) 12 V output power port |
| (7) AI port | (8) PT port | (9) Protective ground point |
| (10) 12 V input power port | (11) 24 V input power port | (12) GE port |
| (13) RST button | - | - |

IL04W00007

Indicators

Indicator	Status	Description	
Running indicator (RUN) RUN 	Green off	Not powered on	
	Blinking green slowly (on for 1s and then off for 1s)	The communication with the CMU is normal.	
	Blinking green fast (on for 0.125s and then off for 0.125s)	The communication with the CMU is interrupted.	
Alarm/maintenance indicator (ALM) ALM 	Alarm status	Red off	No alarm is raised for the SmartModule.
		Blinking red slowly (on for 1s and then off for 4s)	The SmartModule runs with an expired digital certificate.
		Blinking red fast (on for 0.5s and then off for 0.5s)	The SmartModule digital certificate is invalid.
		Steady red	Reserved

2.6.2.3 I/O Expansion Board

NOTE

Only some models are equipped with the I/O expansion board.

The I/O expansion board is located at the top right of the fire cylinder in the control unit cabin. It controls and monitors the door status sensor, sensors, and air conditioners in the ESS, connects cables to the fire suppression system, and black starts the system.

Figure 2-33 Position of the I/O expansion board

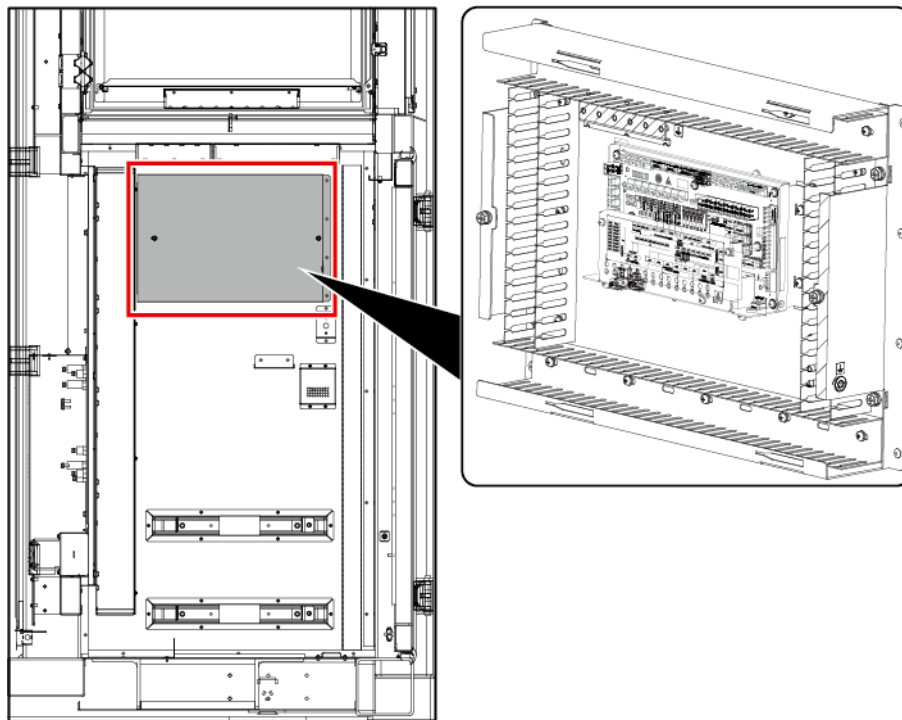

IB04W00105

(1) I/O expansion board

Technical Specifications	I/O Expansion Board
Model	ENF1DETC
Operating voltage	220 V AC/12 V DC/24 V DC
Operating current	≤ 1 A
Operating temperature	-30°C to +55°C
Humidity	≤ 95% RH (non-condensing)
Dimensions (H x W x D)	113.7 mm x 251 mm x 54.5 mm

2.6.3 Environmental Control System

2.6.3.1 T/H Sensor

Figure 2-34 Appearance

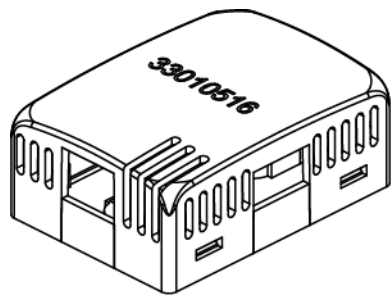

IB04W00024

NOTE

The appearance of the T/H sensor depends on the actual delivery.

Table 2-20 T/H sensor technical specifications

Technical Specifications	T/H sensor
Temperature measuring range	-20°C to +80°C
Temperature precision	≤ ±0.5°C (25°C) ≤ ±1°C (full measuring range)
Operating temperature	-20°C to +80°C
Operating voltage	9-16 V DC
Storage temperature	-40°C to +80°C
Signal output	Two RJ45 ports, bidirectional cascading

The T/H sensor uses an RJ45 connector.

Figure 2-35 Pins of an RJ45 connector

RJ45 female connector

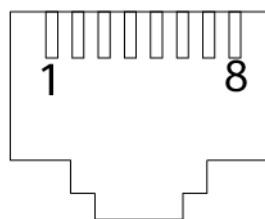

PC03WC0015

Table 2-21 Pin definitions of an RJ45 connector

Pin	Description
Pin 1 or Pin 4	A
Pin 2 or Pin 5	B
Pin 3	V+
Pin 6	Reserved
Pin 7	Reserved
Pin 8	V-

2.6.3.2 Air Conditioner in the Control Unit Cabin

Figure 2-36 Appearance of the air conditioner in the control unit cabin

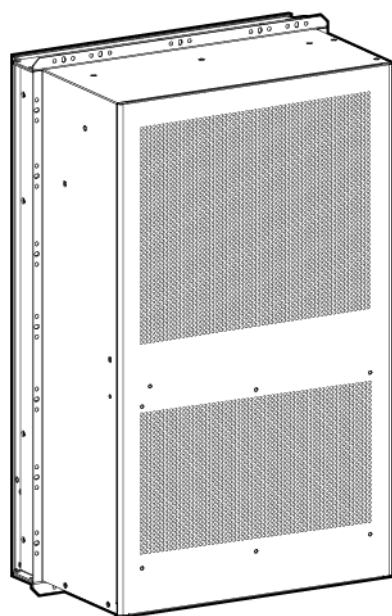

IB04W00015

Technical Specifications	Air Conditioner in the Control Unit Cabin
Air conditioner model	PC3000D-3
Operating temperature	-30°C to +55°C
Rated DC input voltage	-48 V DC
Rated DC input power	1015 W
Rated input current	20.5 A
Cooling capacity (L35/ L35)	2000 W

Technical Specifications	Air Conditioner in the Control Unit Cabin
Heating capacity	1100 W
Dimensions (H x W x D)	<ul style="list-style-type: none">• 746 mm x 446 mm x 300 mm (without flanges)• 783 mm x 479 mm x 300 mm (with flanges)
Net weight	40 kg
IP rating	IP55
Refrigerant	R134a
Surface treatment	Electrostatic spraying

2.6.3.3 Air Conditioner in the Battery Cabin

Figure 2-37 Appearance

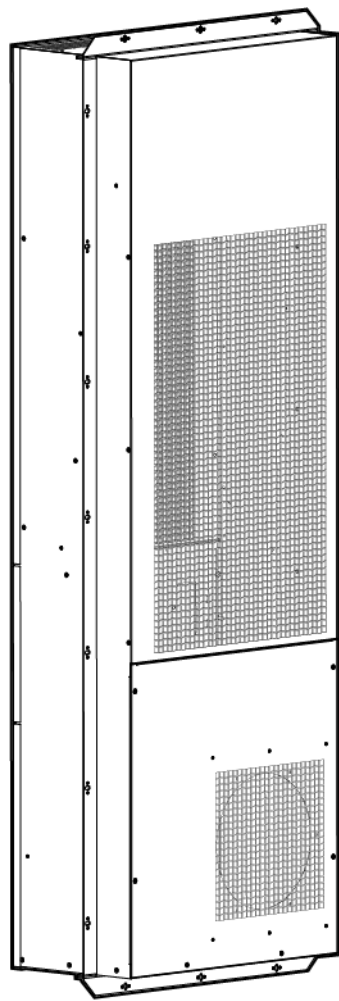

IB04W00014

Technical Specifications	Air Conditioner in the Battery Cabin
Model	PC6H
Rated voltage	208–230 V AC
Voltage range	176–264 V AC
Rated cooling capacity	<ul style="list-style-type: none"> ● 6350 W (L25/L45) ● 9300 W (L25/L35)
Rated heating capacity	3000 W (PTC)
Rated cooling power	<ul style="list-style-type: none"> ● 4150 W (L25/L45) ● 4120 W (L25/L35)
Rated heating power	3000 W (PTC)
Refrigerant (g)	R134a
Operating temperature	–30°C to +55°C
Humidity	5%–100% RH
Dimensions (H x W x D)	1770 mm x 620 mm x 300 mm (with flanges)
Transport performance	Transported by train, vehicle, air, or sea
IP rating	IP55
Fire-retardant performance	Complies with UL 94.
External circulation corrosion	Complies with DKBA0.450.0065.
Safety	Complies with EN 60335, IEC 60950, UL 60950, UL 1995, and UL 484.
Net weight	125 kg

2.6.3.4 Electrode Water Sensor

The water sensor detects water based on the resistance change between both electrodes.

When the electrodes detect water, they are short-circuited and the CMU reports an alarm.

Figure 2-38 Appearance

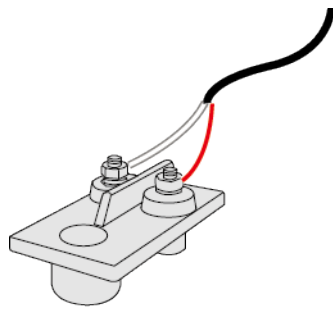

PO01WC0769

Technical Specifications	Electrode Water Sensor
Operating temperature	-40°C to +80°C
Storage temperature	-40°C to +80°C

2.6.3.5 Door Status Sensor

Figure 2-39 Appearance

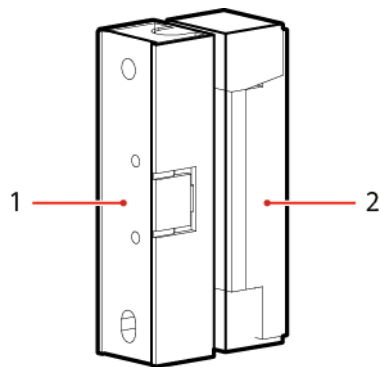

PO02WC0009

(1) Switch

(2) Magnet

Technical Specifications	Door Status Sensor
Connection method	Wiring terminals
Rated current	500 mA
Startup distance	25–45 mm
Rated Power	10 W
Securing method	Screw
Hole spacing	40±0.8 mm

Technical Specifications	Door Status Sensor
Switch voltage	100 V DC (Max)
Contact withstand voltage	150 V DC (Max)
Impedance	0.3 ohms
Switch status	Steady on
Outer material	White acrylonitrile butadiene styrene (ABS) engineering plastic

2.6.3.6 Light

Figure 2-40 Appearance

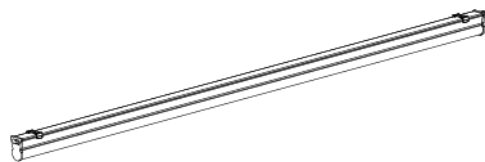

IB04W00057

Technical Specifications	Light
Installation mode	Ceiling-mounting
Type	LED lights
Light holder	Integrated with the lights
IP rating	IP20
Rated voltage	220 V AC
Frequency	50 Hz
Power	10.5 W (68 x 0.2 W)
Color temperature	5700 k
Color	White

2.6.4 Fire Suppression System

 NOTE

The component models in this section may vary.

2.6.4.1 CO Sensor

The CO sensor is used to check the concentration of CO in combustible gases.

Figure 2-41 Appearance

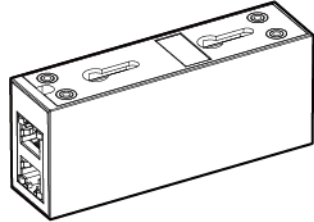

IB03W00001

Technical Specifications	CO Sensor
Dimensions (H x W x D)	40 mm x 97 mm x 25 mm
Operating voltage	8–30 V DC
Stability	≤ ±3% FS/year
Precision	≤ ±10% FS
Power consumption	0.12 W
Output signal	RS485
Operating temperature	–25°C to +55°C
Humidity	5%–95% RH (non-condensing)
Resolution	≤ 30 ppm
Response time	≤ 60s
Cabling mode	RJ45 network port
Installation mode	Gourd-shaped mounting hole/Nut/Magnet

Figure 2-42 Pins of an RJ45 connector

RJ45 female connector

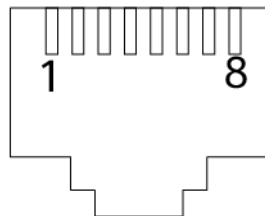

PC03WC0015

Table 2-22 Pin definitions of an RJ45 connector

Pin	Description
Pin 1 or pin 4	A
Pin 2 or pin 5	B
Pin 3	V+
Pin 6	Reserved
Pin 7	Reserved
Pin 8	V-

2.6.4.2 Air Exhaust Module

The air exhaust module is the actuator of the active air exhaust system. When the combustible gas is released from the battery, the air exhaust module reduces the concentration of combustible gas in the battery cabin.

Figure 2-43 Appearance

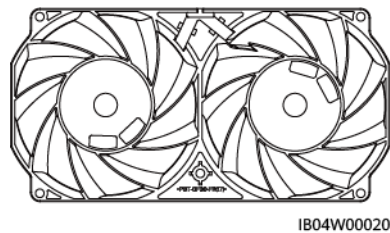

Technical Specifications	Air Exhaust Module
Dimensions (H x W x D)	38 mm x 194 mm x 99 mm
Operating voltage	36–72 V DC
Rated rotating speed	9500±10% RPM
Operating temperature	-25°C to +70°C

2.6.4.3 Air Exhaust Controller

The air exhaust controller TCUE receives commands from the CMU and adjusts the fan speed.

Figure 2-44 Appearance

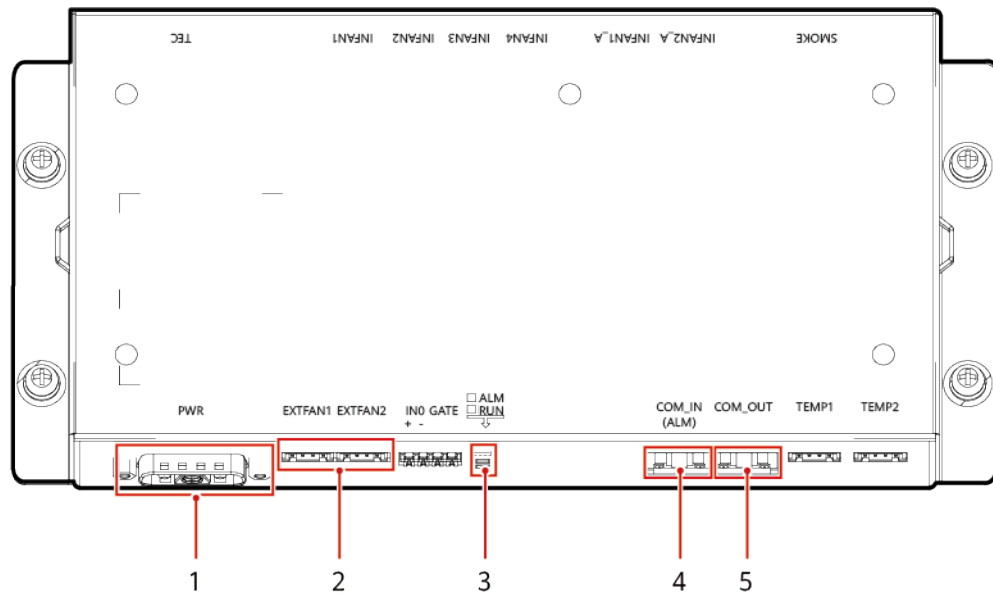

XW00000209

- (1) Power input ports
- (2) Fan ports
- (3) Indicators
- (4) Communications port 1
- (5) Communications port 2

Table 2-23 Indicator description

Silkscreen	Color	Status	Description
RUN	Green	Steady on	Power supply to the board is normal but no program is running.
		Blinking at 0.5 Hz	The system is running properly.
		Blinking at 4 Hz	Serial port communication is interrupted or the board is not registered.
		Off	The system is not powered on.
ALM	Red	Steady on	Power supply to the board is normal but no program is running.
		Blinking at 0.5 Hz	An alarm is generated.
		Off	No alarm is generated.

2.6.4.4 Extinguishant Control Panel

The extinguishant control panel is used for fire alarms and automatic fire suppression control. For details, see the extinguishant control panel manual delivered with the ESS.

Model: K11031M2

Figure 2-45 Appearance

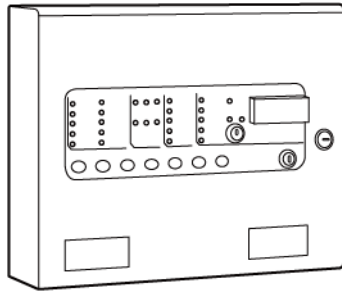

IB04W00068

Technical Specifications	Extinguishant Control Panel
Model	K11031M2
Dimensions (H x W x D)	310 mm x 385 mm x 90 mm
Operating voltage	<ul style="list-style-type: none"> 230 V+10%/-15% AC Sealed lead-acid batteries connected in series 12 V/7 Ah x 2
Power	AC input \leq 100 W
Capacity	<ul style="list-style-type: none"> Number of detector loops: 3 Number of detectors connected to each loop: \leq 32
Detector loop requirements	<ul style="list-style-type: none"> Wire system of the detector loop: two-wire system Length of the detector loop: \leq 1000 m
Enclosure material	Low-carbon steel
Operating temperature	-5°C (\pm 3°C) to +55°C (\pm 2°C)
Humidity	\leq 95% RH (non-condensing)
IP rating	IP30

Technical Specifications	Sealed Lead-Acid Battery
Rated voltage	12 V
Capacity	7 Ah

Technical Specifications	Sealed Lead-Acid Battery
Required certification	CE or UL certification
Complied standard	IEC 61056

Model: JB-QBL-QM210

Figure 2-46 Appearance

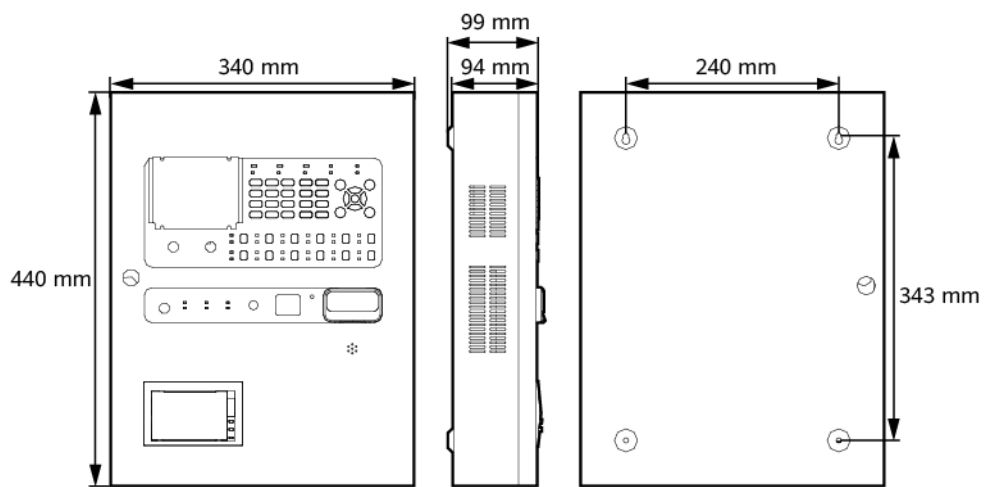

IB04W00032

Technical Specifications	Extinguishant Control Panel
Model	JB-QBL-QM210
Dimensions (H x W x D)	440 mm x 340 mm x 99 mm
Operating voltage	<ul style="list-style-type: none"> AC input voltage: 220±20% V AC, 50 Hz Maintenance-free battery 12 V DC/5 Ah x 2
24 V DC output	Long-term and continuous: 3 A
Power	AC input ≤ 120 W
Capacity	<ul style="list-style-type: none"> Number of detector loops: 3 (One is connected to a common heat detector, one is connected to a common smoke detector, and the remaining one is reserved.) Number of detectors connected to each loop: ≤ 24
Wiring mode	Non-polarized two-wire system

Technical Specifications	Extinguishant Control Panel
Detector loop requirements	<ul style="list-style-type: none">• Wire system of the detector loop: two-wire system• Length of the detector loop: ≤ 1000 m
Enclosure material	A3 steel
Installation mode	Wall-mounted
Operating temperature	-10°C to +55°C
Humidity	≤ 95% RH (non-condensing)
IP rating	IP30

Technical Specifications	Sealed Lead-Acid Battery
Rated voltage	12 V
Capacity	5 Ah
Required certification	CE or UL certification
Complied standard	GB 19639

2.6.4.5 Fire Cylinder

The fire cylinder stores fire extinguishant and is used together with related components, including solenoid valves, pressure gauges, and pipes.

NOTICE

Keep the fire cylinder away from direct sunlight.

Figure 2-47 Appearance

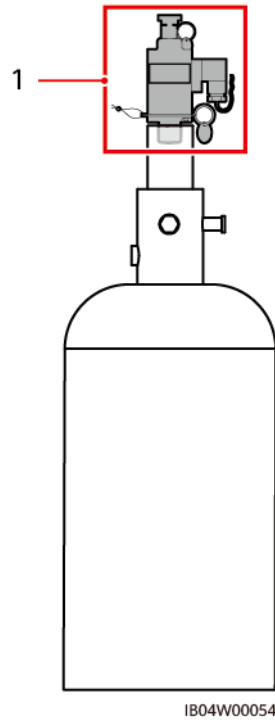

(1) Position of the solenoid valve after installation

NOTE

The actual appearance and color of the fire cylinder may vary.

Technical Specifications	Fire Cylinder					
	Model	227M38 UFAA	SPS020-MS-032B-EN	P0009438	NCM38U FAA	GQQ40/2.5
Operating voltage	24 V DC	24 V DC	24 V DC	24 V DC	24 V DC	24 V DC
Storage pressure (at 20°C)	2.5 Mpa	2.5 Mpa	2.5 Mpa	2.5 Mpa	2.5 Mpa	2.5 Mpa

Technical Specifications	Fire Cylinder					
	Maximum operating pressure (at 50°C)	4.2 Mpa	4.2 Mpa	3 Mpa	3 Mpa	4.2 Mpa
Startup mode	Electromagnetic startup	Electromagnetic startup	Electromagnetic startup	Electromagnetic startup	Electromagnetic startup	Electromagnetic startup
Electromagnetic startup voltage / current	24 V DC/0.6 A	24 V DC/0.6 A	24 V DC/0.6 A	24 V DC/0.6 A	24 V DC/1 A	24 V DC/1 A
Operating temperature	-10°C to +55°C	-10°C to +60°C	-10°C to +55°C	-10°C to +55°C	0°C to 50°C	0°C to 50°C
Relative humidity	≤ 95% RH (non-condensing at 40°C)	≤ 95% RH (non-condensing at 40°C)	≤ 95% RH (non-condensing at 40°C)	≤ 95% RH (non-condensing at 40°C)	≤ 95% RH (non-condensing)	≤ 95% RH (non-condensing)
Outer diameter of cylinder	≤ 324 mm	324 mm	330 mm	300 mm	328 mm	328 mm
Cylinder height	≤ 706 mm	730 mm	≤ 850 mm	≤ 850 mm	918 mm	918 mm
Extinguishant release time	6s to 10s	≤ 10s	≤ 10s	≤ 10s	≤ 10s	≤ 10s

Technical Specifications	Fire Cylinder					
Hose	Length: 800 mm; diameter: DN20	Length: 800 mm; diameter: DN20	Length: 800 mm; diameter: DN20	Length: 700 mm; diameter: DN20	Length: 800 mm; diameter: DN20	Length: 800 mm; diameter: DN20
Extinguishant	Heptafluoropropane	Heptafluoropropane	Perfluorohexanone	Perfluorohexanone	Heptafluoropropane	Perfluorohexanone
Cylinder volume	38 L	32 L	40 L	38 L	40 L	40 L

2.6.4.6 Input/Output Module

The input/output modules receive early fire signals from the CMU and send the signals to the extinguishant control panel to implement early fire response and control.

 **NOTE**

Only some models are equipped with the input/output module.

Figure 2-48 Input/Output module

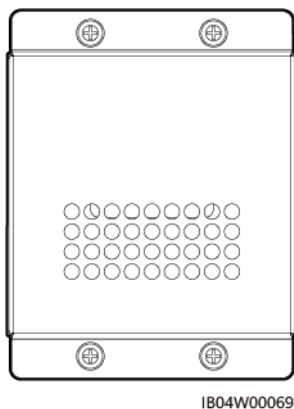
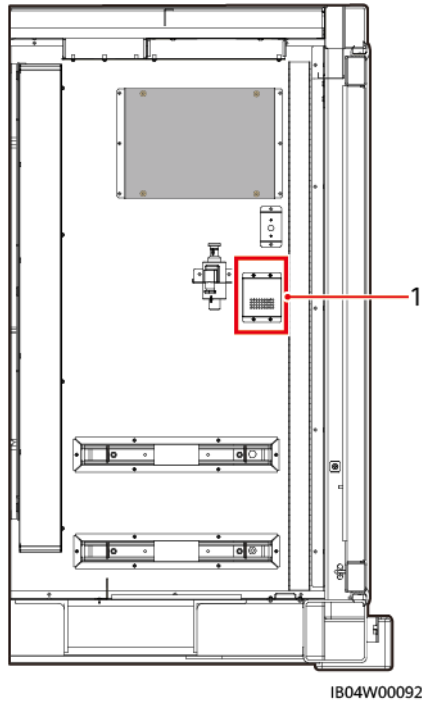

Figure 2-49 Position of the input/output module



(1) Position of the input/output module

Table 2-24 Technical Specifications of the input/output module

Technical Specifications	Input/Output Module
Model	KZJ-956
Working mode	Non-polarized two-wire system
Quiescent current	< 0.6 mA
Operating current	< 10 mA
Output control contact capacity	2 A; 30 V DC
Working status indication	<ul style="list-style-type: none"> The indicator blinks about every 12 seconds in the inspection state, and is steady on in the output state. The input indicator is steady on in the input state.
Operating temperature	-10°C to +50°C
Relative humidity	≤ 95% RH (non-condensing at 40°C ±2°C)
Terminal load	47 kilo-ohm resistor
Dimensions (H x W x D)	86 mm x 86 mm x 40 mm (with a base)

Technical Specifications	Input/Output Module
Weight	Approx. 130 g (with a base)

2.6.4.7 Fire Signal Transfer Board

NOTE

Only some models are equipped with the fire signal transfer board.

Figure 2-50 Appearance

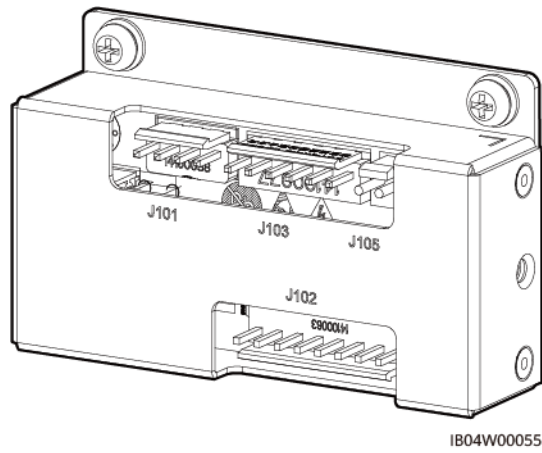
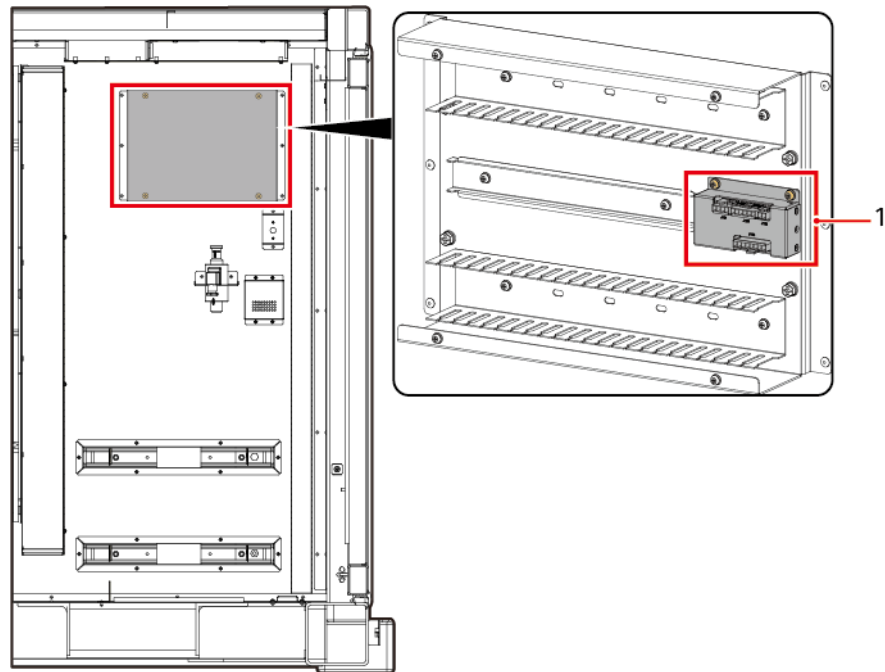

Figure 2-51 Position of the fire signal transfer board



(1) Position of the fire signal transfer board

Technical Specifications	Fire Signal Transfer Board
Model	ENF1DETAA
Operating voltage	24 V
Operating current	≤ 1 A
Operating temperature	-30°C to +55°C
Humidity	≤ 95% RH (non-condensing)
Dimensions (H x W x D)	55 mm x 95 mm x 24 mm

2.6.4.8 Heat Detector

Figure 2-52 Appearance

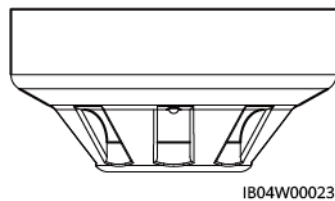

Table 2-25 Indicator description

Item	Color	Status	Description
Indicators	Red	Steady on	Enters alarm status
		Blinking	Enters monitoring status

Table 2-26 Technical specifications of the heat detector

Technical Specifications	Heat Detector	
Configuring model	55000-121-EH/ 55000-121-WZ	JTW-ZD-920
Dimensions	100 mm diameter x 50 mm height (with base)	100 mm diameter x 56 mm height (with base)
Operating voltage	Supply voltage: 9 V to 33 V	24 V
Net weight	Approx. 80 g	Approx. 65 g
Alarm category	A1R	A2R, 54°C to 70°C

Technical Specifications	Heat Detector	
Enclosure material	Polycarbonate, white	ABS, white
Cabling mode	Polarized two-wire system	Non-polarized two-wire system
Operating current	Monitoring status < 55 μ A @24 V DC; alarm status < 52 mA	Monitoring status < 300 μ A; alarm status < 1.5 mA
Operating temperature	-20°C to +90°C	-10°C to +50°C
Humidity	\leq 95% RH (non-condensing)	\leq 95% RH (non-condensing)
Installation mode	Ceiling-mounted	Ceiling-mounted
Encoding mode	No encoding	The encoder can be used for onsite encoding. The address ranges from 1 to 324.
Protected area	About 50 m ² (storey height \leq 8 m), referring to GB50116-2013 Code for Design of Automatic Fire Alarm System	About 30 m ² (storey height \leq 8 m), referring to GB50116-2013 Code for Design of Automatic Fire Alarm System
Applicable base	45681-200	DZ-916
IP rating	IP54	IP30

2.6.4.9 Smoke Detector

The smoke detector can detect the smoke concentration in the environment.

⚠ CAUTION

Do not use smoke detectors in condensation scenarios. Otherwise, false alarms may be generated. If a false alarm is generated, handle the alarm by referring to section 2.4 "3802 Fire Alarm" in the [LUNA2000-2.0MWH and 1.0MWH Series Smart String ESS Alarm Reference](#).

Figure 2-53 Appearance

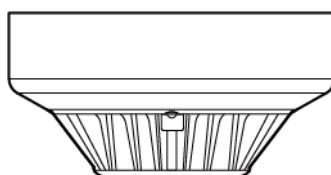

IB04W00027

Table 2-27 Indicator description

Item	Color	Status	Description
Indicator	Red	Steady on	Enters alarm status
		Blinking	Enters monitoring status

Table 2-28 Technical specifications

Technical Specifications	Smoke Detector
Model	55000-316
Dimensions	100 mm diameter x 50 mm height (with mounting base)
Operating voltage	Supply voltage: 9 V DC to 33 V DC
Net weight	Approx. 99 g
Enclosure material	Polycarbonate, white
Cabling mode	Polarized two-wire system
Operating current	<ul style="list-style-type: none"> Power-up surge current: 115 μA at 24 V Alarm LED current: 4 mA
Operating temperature	-20°C to +60°C
Humidity	\leq 95% RH (non-condensing)

Table 2-29 Technical specifications

Technical Specifications	Smoke Detector
Model	JTY-GD-930
Dimensions	100 mm diameter x 54 mm height (with mounting base)
Operating voltage	24 V
Net weight	Approx. 82 g
Enclosure material	ABS, white
Cabling mode	Non-polarized two-wire system
Operating current	Monitoring status < 300 μ A; alarm status < 1.5 mA

Technical Specifications	Smoke Detector
Operating temperature	-10°C ~ +55°C
Humidity	≤ 95% RH (non-condensing)
Installation height	≤ 12 m
Encoding mode	The encoder can be used for onsite encoding. The address ranges from 1 to 324.
Protection area	About 80 m ² (storey height ≤ 12 m), referring to GB50116-2013 Code for Design of Automatic Fire Alarm System
Installation mode	Ceiling-mounted
Applicable base	DZ-916

2.6.4.10 Fire Alarm Horn/Strobe

The fire alarm horn/strobe is used for audible and visual alarm in the area where an accident occurs.

Table 2-30 Indicator description

Item	Color	Status	Description
Indicator	Red	Steady on	The fire alarm horn/strobe is in the alarm state.
		Blinking	The fire alarm horn/strobe is in the monitoring state.

Model: 958CHL1001

Figure 2-54 Appearance

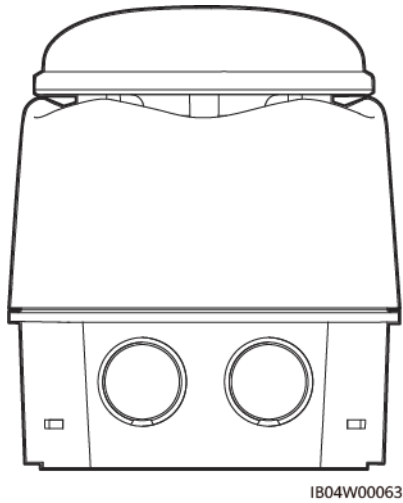

Technical Specifications	Fire Alarm Horn/Strobe
Model	958CHL1001
Operating voltage	Bus 24 V DC
Operating current	Maximum 55 mA @ 24 V DC
Flashing frequency	1 Hz
Operating temperature	-20°C to +70°C
Humidity	≤ 95% RH (non-condensing)
Alarm volume	88+ dBA @ 24 V
Dimensions (H x W x D)	109 mm x 92 mm x 92 mm (with a base)
Weight	Approx. 155 g (with a base)
Enclosure material	ABS, red
Wiring mode	Polarized two-wire system
IP rating	IP33C

Model: SG-993

Figure 2-55 Appearance

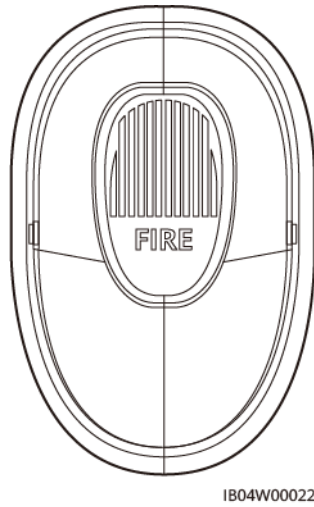

Technical Specifications	Fire Alarm Horn/Strobe
Model	SG-993
Operating voltage	Bus 24 V DC
Operating current	Monitoring status < 1 mA; alarm status < 120 mA
Flashing frequency	1–1.5 Hz
Operating temperature	0–55°C
Humidity	≤ 95% RH (non-condensing)
Alarm volume	75–95 dB
Dimensions (H x W x D)	152 mm x 99 mm x 53 mm (with a base)
Weight	Approx. 155 g (with a base)
Enclosure material	ABS, red
Installation mode	Wall-mounted
Encoding mode	Electrical coding via the encoder. The address range is 1 to 324.
Wiring mode	Non-polarized two-bus (L1, L2) system and power cable
IP rating	IP30

2.6.4.11 Extinguishant Release Indicator

The extinguishant release indicator is used for audible and visual alarm in the extinguishant protection area.

Model: K27102

Figure 2-56 Appearance



IB04W00059

Technical Specifications	Extinguishant Release Indicator
Model	K27102
Operating voltage	Bus -15 V DC to +30 V DC
Operating current	Maximum 140 mA @ 24 V DC
Operating temperature	-15°C to +40°C
Humidity	≤ 95% RH (non-condensing)
Dimensions (H x W x D)	195 mm x 300 mm x 50 mm
Net weight	Approx. 2 kg
Enclosure material	ABS, gray
Wiring mode	Polarized two-wire system
IP rating	IP30

Model: QM-ZSD-02

Figure 2-57 Appearance

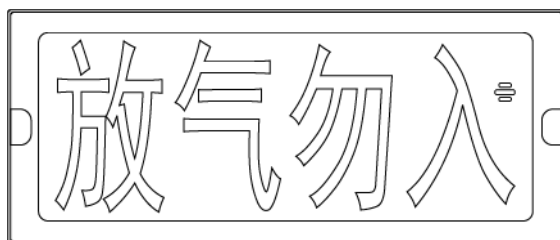

IB04W00017

Technical Specifications	Extinguishant Release Indicator
Model	QM-ZSD-02
Operating voltage	Bus 24 V + 24 V DC
Operating current	<ul style="list-style-type: none"> Bus current in static state: $\leq 500 \mu\text{A}$ When an alarm is generated, bus current $\leq 4 \text{ mA}$, 24 V DC current $\leq 150 \text{ mA}$
Flashing frequency	1-2 Hz
Operating temperature	0-55°C
Humidity	$\leq 95\%$ RH (non-condensing)
Luminous text surface brightness	50-300 cd/m^2
Sound pressure level	75-120 dB
Tone changing period	0.2-5s
Dimensions (H x W x D)	150 mm x 330 mm x 35 mm
Net weight	Approx. 435 g
Enclosure material	ABS, white
Encoding mode	Electrical coding via the encoder. The address range is 1 to 324.
Wiring mode	Four-wire, non-polarized two-bus (L1, L2) signal system and 24 V DC power cable (non-polarized wiring)
Installation mode	Wall-mounted
IP rating	IP30

2.6.4.12 Water Sprinkler System

The water sprinkler system is used to put out a fire in the ESS if the fire suppression system fails or the fire cannot be put out due to other uncontrollable factors.

NOTE

Some models are configured with a water sprinkler system. The actual configurations may vary.

NOTICE

The valve of the water sprinkler system is located on the side of the ESS and cannot be monitored through the SACU. Therefore, the customer shall enhance the management on the ESS site to prevent false triggering. Equipment damage caused by false triggering is not covered by the warranty.

Figure 2-58 Position of the water sprinkler port

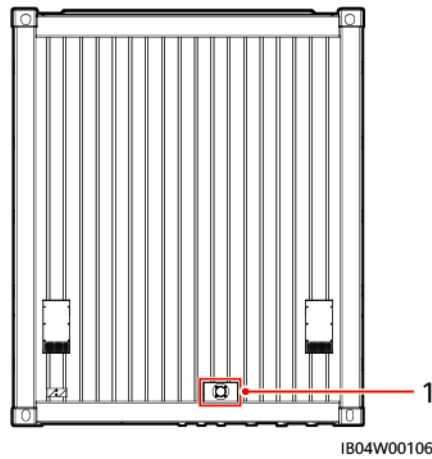

(1) Position of the water sprinkler port

Figure 2-59 Water sprinkler system layout
Front View

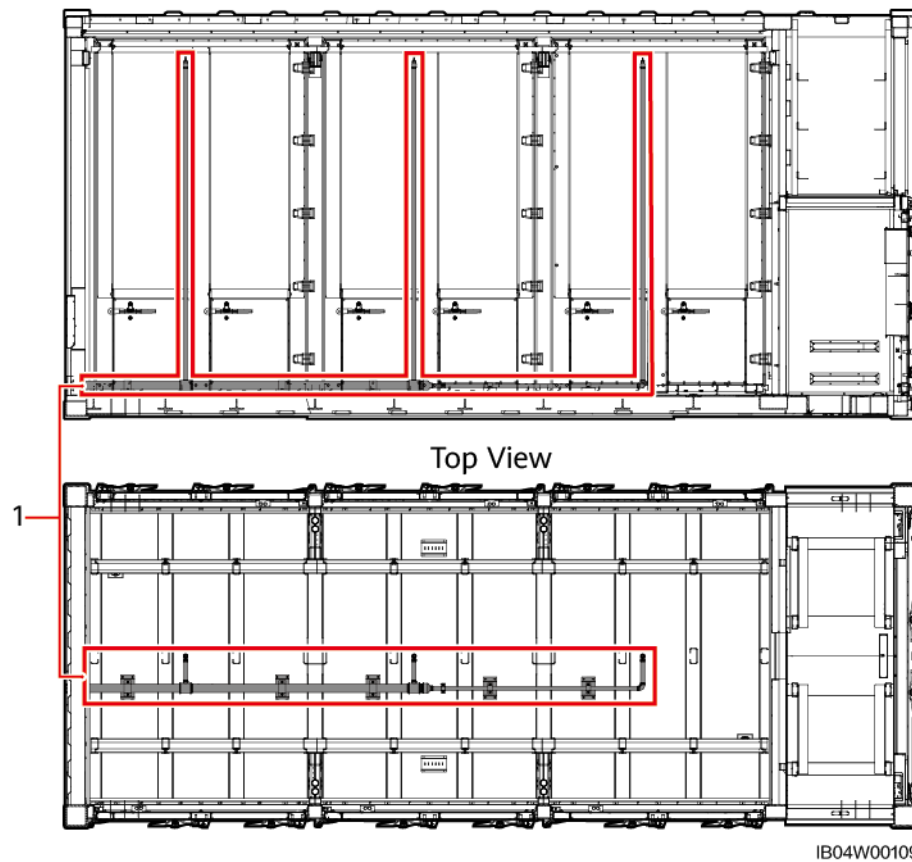

(1) Water sprinkler system layout

Table 2-31 Port specifications

Item	Specifications
External thread	BSPT 2"
Thread length	20 mm

Table 2-32 Water inlet requirements

Item	Specifications
Total inlet water flow	175.38 L/min
Water inlet pressure	0.94 bar
Water inlet pipe diameter	DN50

Startup Requirements

NOTICE

- Check that the extinguishant monitoring devices are connected to the plant control system.
- Check that the ambient temperature monitoring devices in the ESS are connected to the plant control system.

- Check the status of the extinguishant in the ESS via the plant control system. If the extinguishant is not released, do not start the water sprinkler system.
- Check that the extinguishant has been released and at least two temperature monitoring points exceed 80°C in the ESS via the plant control system. Then start the water sprinkler system.
- Start the water sprinkler system in the ESS if open flames outside the ESS are detected through the video surveillance of the plant control system.

NOTE

It is recommended that the video surveillance system with the infrared temperature measurement function be used.

Emergency Rescue Suggestions

Rescue personnel are not allowed to stand in the door opening areas of the ESS, and must be away from the areas at a distance of greater than or equal to 20 m.

2.7 Working Principles

2.7.1 Circuit Diagrams

NOTE

The ESS has various circuit diagrams. The following figures are for reference only.

Table 2-33 Switch configurations

Model	Air Conditioner Position in the Battery Cabin	Air Conditioner Switch No.	Battery Pack Fan Switch No.	Smart Rack Controller Switch No.	DC Circuit Breaker No. in the Control Unit Cabin
LUNA2000-2.0MWH-4 H1	5/11	3FCB5, 3FCB11	7FCB7-7FCB12	7FCB16-7FCB18	1Q2-3Q2

Model	Air Conditioner Position in the Battery Cabin	Air Conditioner Switch No.	Battery Pack Fan Switch No.	Smart Rack Controller Switch No.	DC Circuit Breaker No. in the Control Unit Cabin
LUNA2000-2.0MWH-2H1	1/3/5/7/9/11	3FCB1, 3FCB3, 3FCB5, 3FCB7, 3FCB9, 3FCB11	7FCB7-7FCB15, 7FCB19-7FCB27	7FCB16, 7FCB17, 7FCB18	1Q2-3Q2
LUNA2000-2.0MWH-2H1	1/4/7/10	3FCB1, 3FCB4, 3FCB7, 3FCB10	7FCB7-7FCB12	7FCB16, 7FCB17, 7FCB18	1Q2-6Q2
LUNA2000-2.0MWH-2H0	2/4/6/8/10/12	3FCB2, 3FCB4, 3FCB6, 3FCB8, 3FCB10, 3FCB12	7FCB7-7FCB15, 7FCB19-7FCB27	7FCB16, 7FCB17, 7FCB18	1Q2-3Q2
LUNA2000-2.0MWH-HE2H1	1/4/7/10	3FCB1, 3FCB4, 3FCB7, 3FCB10	7FCB7-7FCB12	7FCB16, 7FCB17, 7FCB18	1Q2-6Q2
LUNA2000-2.0MWH-HE1H1	1/3/5/7/9/11	3FCB1, 3FCB3, 3FCB5, 3FCB7, 3FCB9, 3FCB11	7FCB7-7FCB15, 7FCB19-7FCB27	7FCB16, 7FCB17, 7FCB18, 7FCB28, 7FCB29, 7FCB30	1Q2-6Q2
LUNA2000-2.0MWH-1H1	1/3/5/7/9/11	3FCB1, 3FCB3, 3FCB5, 3FCB7, 3FCB9, 3FCB11	7FCB7-7FCB15, 7FCB19-7FCB27	7FCB16, 7FCB17, 7FCB18, 7FCB28, 7FCB29, 7FCB30	1Q2-6Q2
LUNA2000-2.0MWH-1H1	1/2/4/5/7/8/10/11	3FCB1, 3FCB2, 3FCB4, 3FCB5, 3FCB7, 3FCB8, 3FCB10, 3FCB11	7FCB7-7FCB15, 7FCB19-7FCB27	7FCB16, 7FCB17, 7FCB18, 7FCB28, 7FCB29, 7FCB30	1Q2-6Q2

Model	Air Conditioner Position in the Battery Cabin	Air Conditioner Switch No.	Battery Pack Fan Switch No.	Smart Rack Controller Switch No.	DC Circuit Breaker No. in the Control Unit Cabin
LUNA2000-2.0MWH-1H0	1/2/4/5/7/8/10/11	3FCB1, 3FCB2, 3FCB4, 3FCB5, 3FCB7, 3FCB8, 3FCB10, 3FCB11	7FCB7- 7FCB15, 7FCB19- 7FCB27	7FCB16, 7FCB17, 7FCB18, 7FCB28, 7FCB29, 7FCB30	1Q2-6Q2
LUNA2000-1.0MWH-1H1	1/5/7	3FCB1, 3FCB5, 3FCB7	7FCB7- 7FCB15	7FCB16- 7FCB18	1Q2-6Q2
LUNA2000-1.0MWH-ES1H1	1/5/7	3FCB1, 3FCB5, 3FCB7	7FCB7- 7FCB15	7FCB16- 7FCB18	1Q2-6Q2

LUNA2000-2.0MWH-4H1

Figure 2-60 Circuit diagram 1

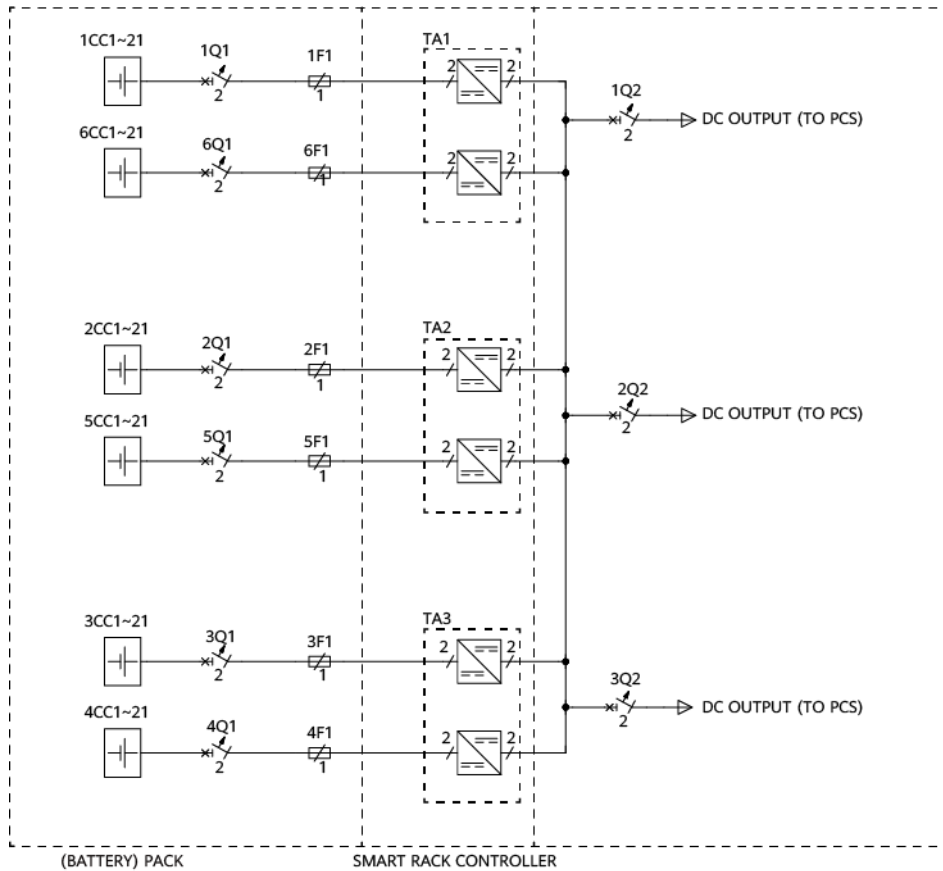

IB04P00016

Figure 2-61 Circuit diagram 2

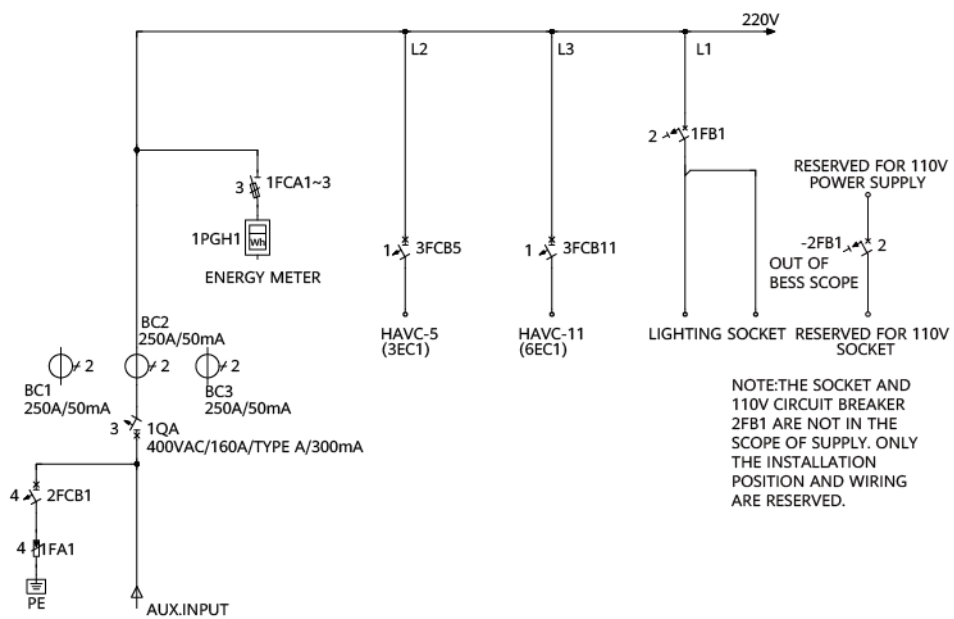

IB04P00017

Figure 2-62 Circuit diagram 3

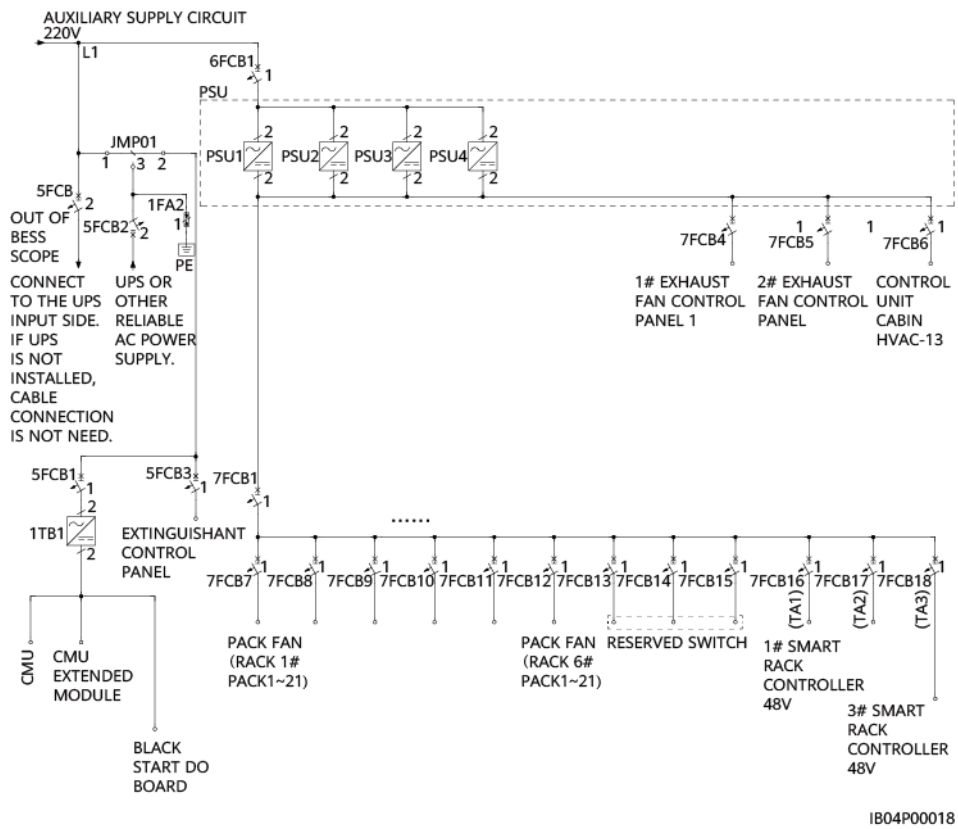

LUNA2000-1.0MWH-1H1/LUNA2000-1.0MWH-ES1H1

Figure 2-63 Circuit diagram 1

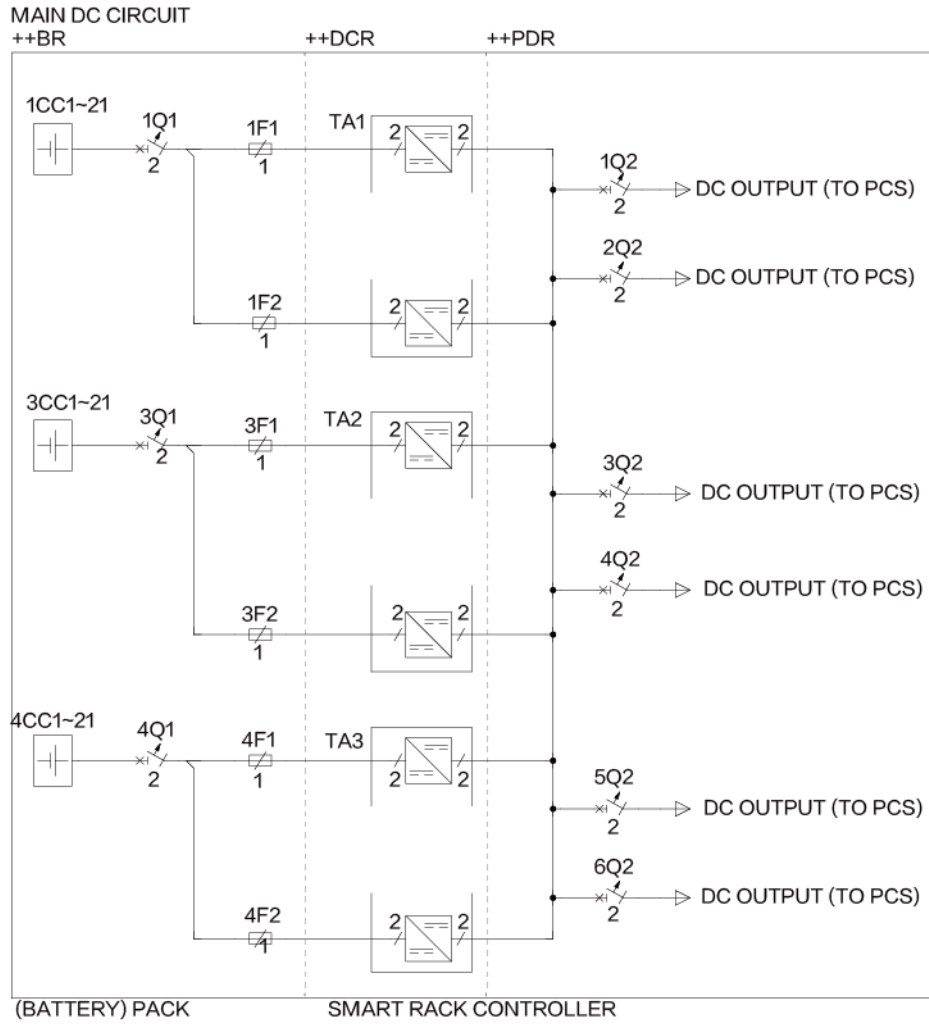
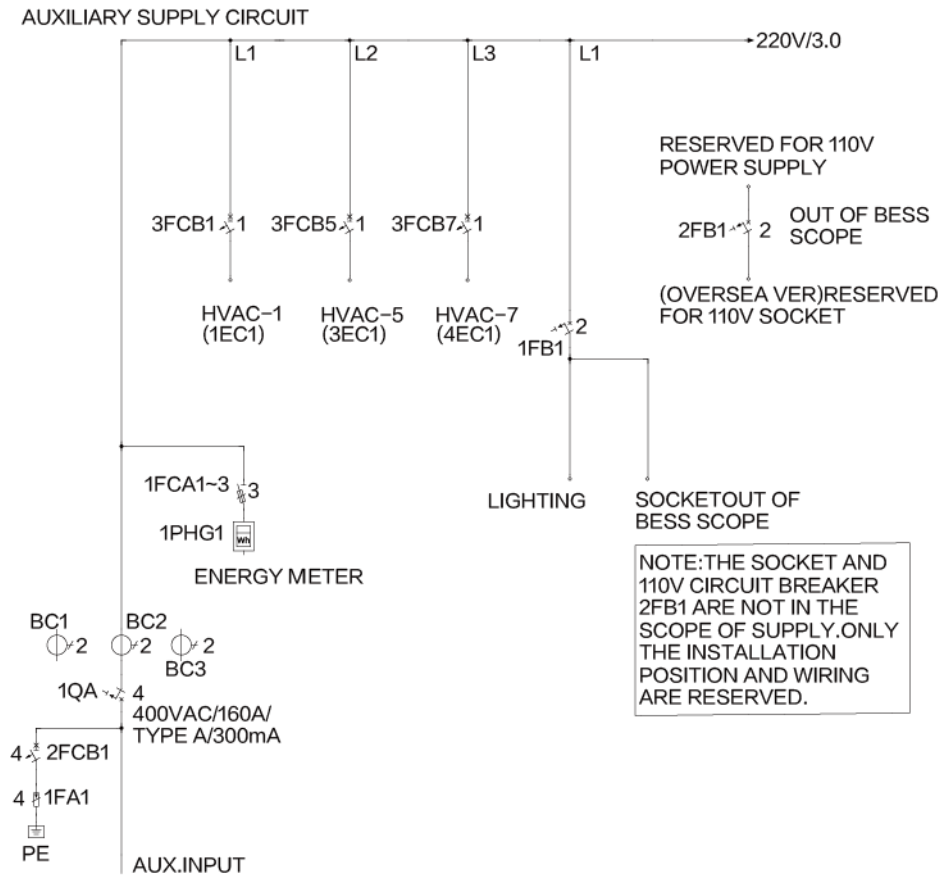
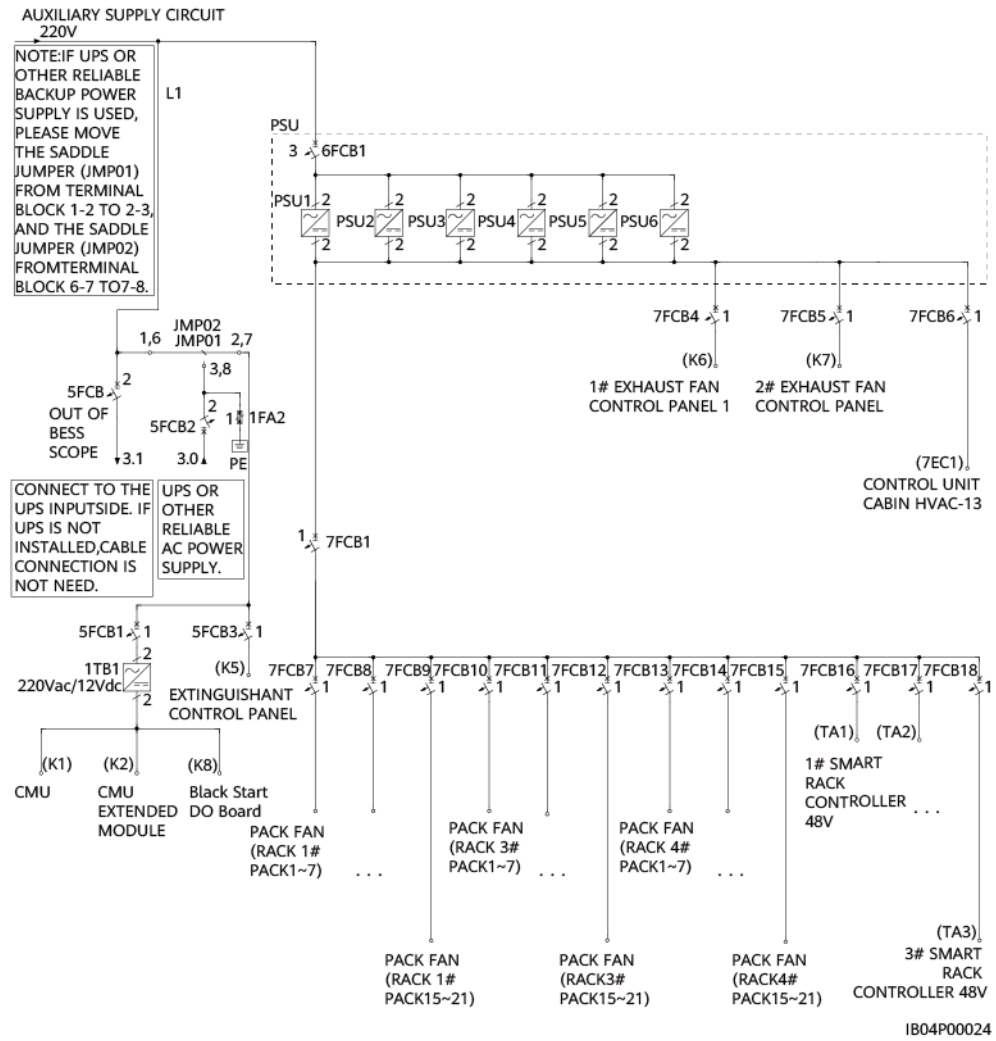

Figure 2-64 Circuit diagram 2



IB04P00023

Figure 2-65 Circuit diagram 3



LUNA2000-2.0MWH-1H1/LUNA2000-2.0MWH-HE1H1

Figure 2-66 Circuit diagram 1

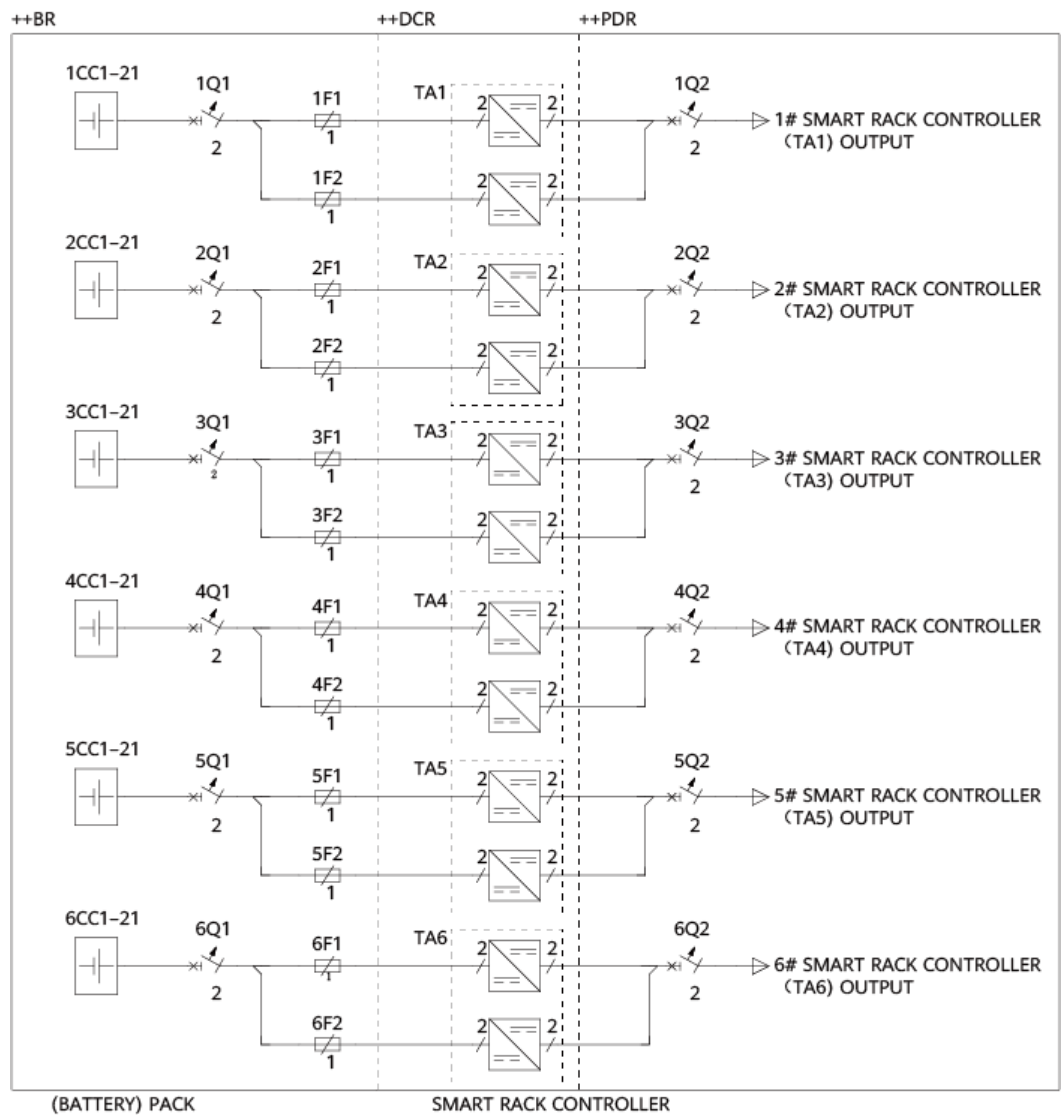

IB04P00028

Figure 2-67 Circuit diagram 2

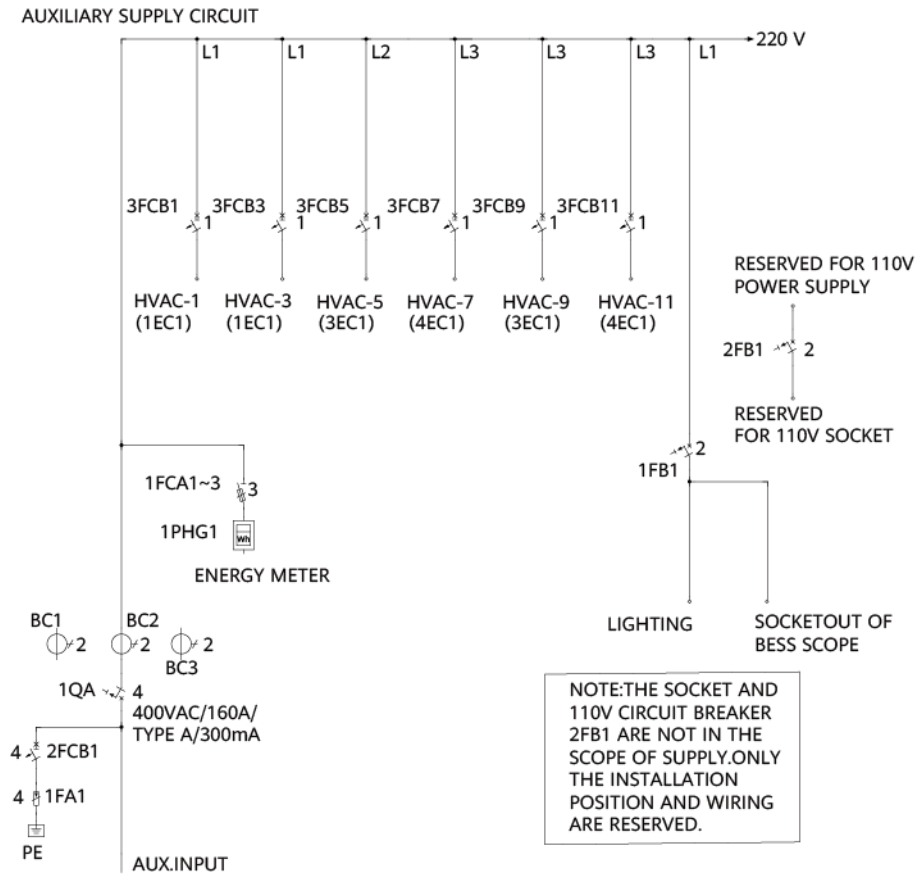

IB04P00029

Figure 2-68 Circuit diagram 3

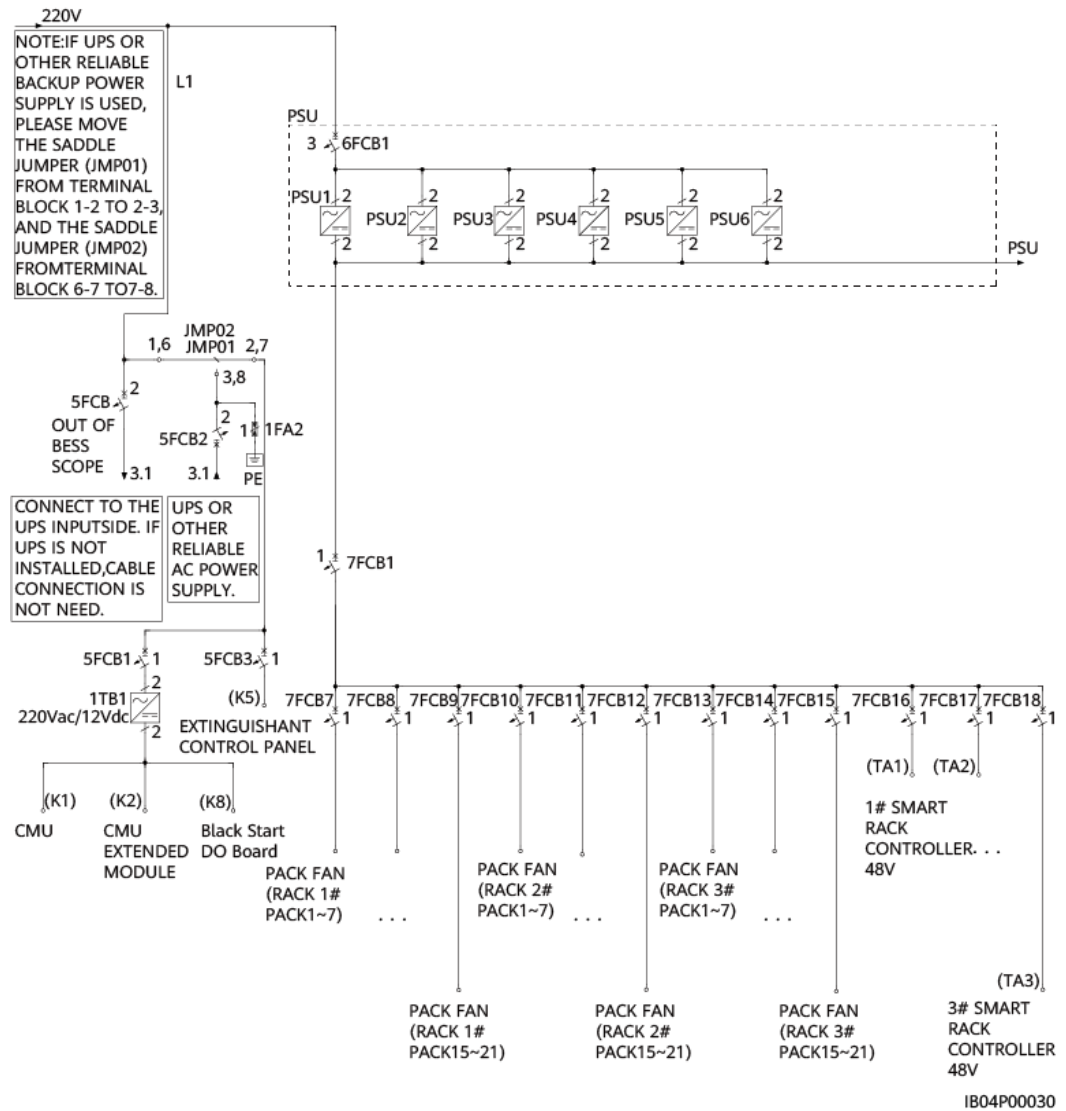
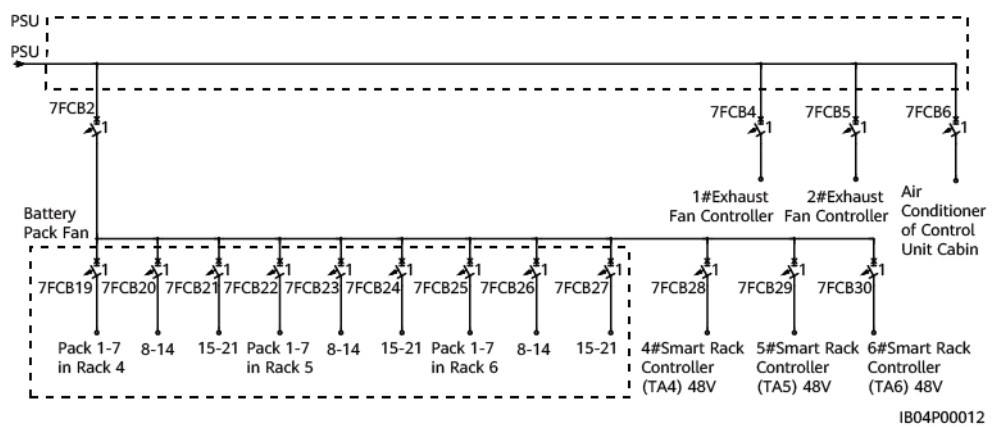
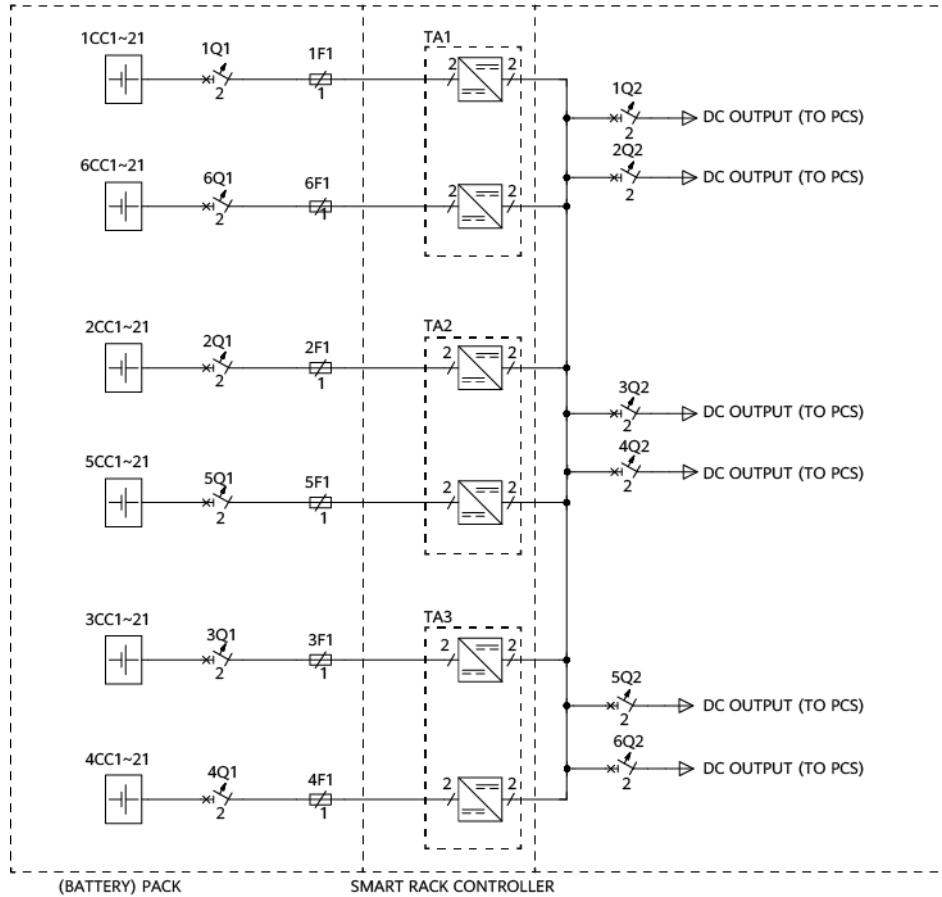

Figure 2-69 Circuit diagram 4



LUNA2000-2.0MWH-2H1/LUNA2000-2.0MWH-HE2H1/LUNA2000-2.0MWH-2H0

Figure 2-70 Circuit diagram 1



IB04P00020

Figure 2-71 Circuit diagram 2

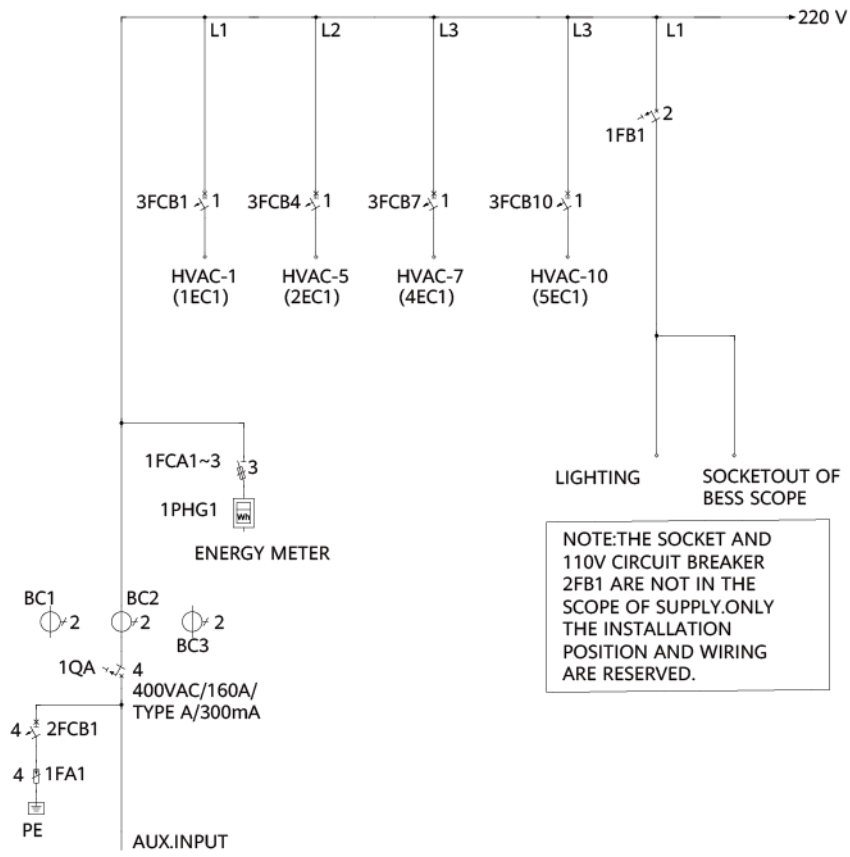

IB04P00026

Figure 2-72 Circuit diagram 3

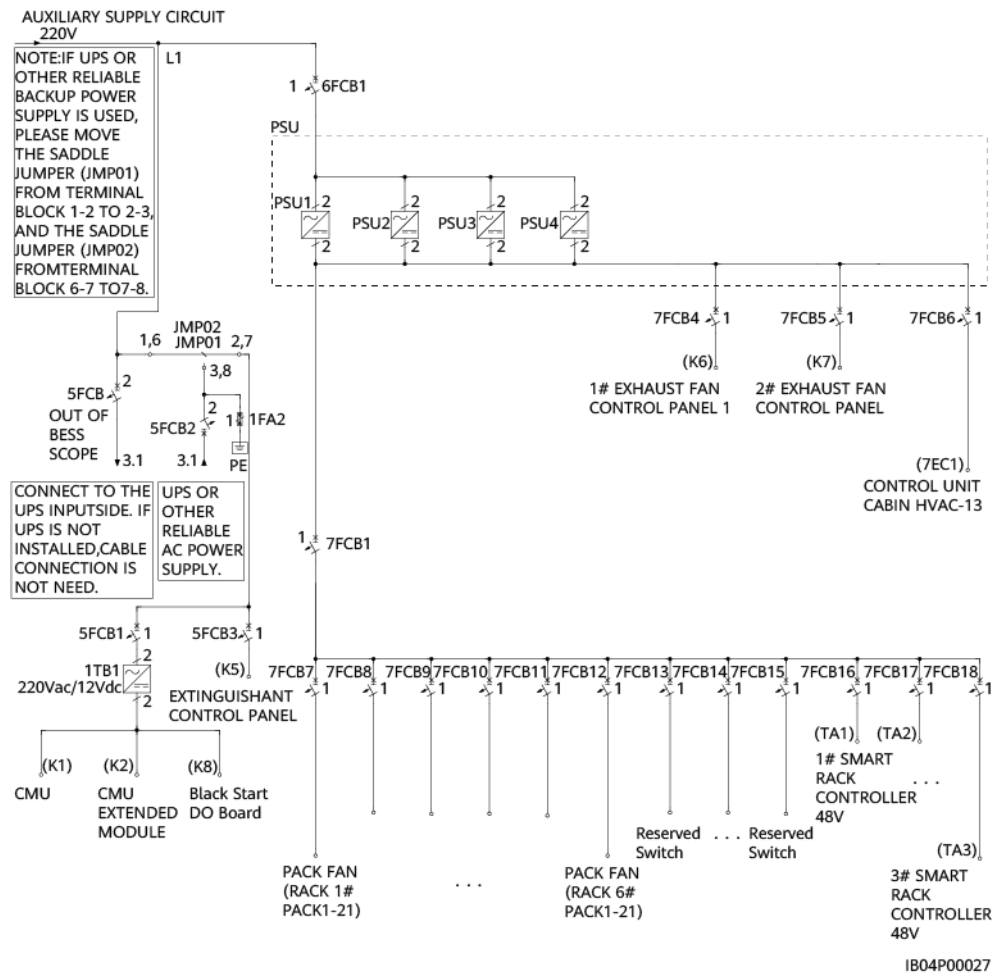

2.7.2 Working Modes

The ESS has six working modes: running, hibernation, self-check, fault, offline, and loading.

Table 2-34 Working mode description

Working Mode	Description
Running	The ESS is charging from an external DC source or discharging for external devices.
Hibernation	The ESS stops charging and discharging and shuts down the Smart Rack Controllers. <ul style="list-style-type: none"> In the running mode, if the ESS receives a hibernation command, it enters the hibernation mode. In the hibernation mode, if the ESS receives a running command, it enters the running mode.
Self-check	The ESS is in progress of a self-check.

Working Mode	Description
Fault	If a Smart Rack Controller or a battery pack is faulty, the ESS enters the fault mode.
Offline	Smart Rack Controllers are disconnected from the CMU.
Loading	After the CMU starts, the ESS is waiting for the energy storage units (ESUs) to be connected.

2.8 Typical Application Scenarios

For details about the on-grid scenario, see [LUNA2000-2.0MWH and 1.0MWH Series Utility-Scale Energy Storage On-Grid Solution User Manual](#). For details about the microgrid scenario, see [LUNA2000-2.0MWH and 1.0MWH Series Utility-Scale Energy Storage Microgrid Solution User Manual](#) or [LUNA2000-2.0MWH and 1.0MWH Series Commercial and Industrial Off-Grid Solution User Manual \(Japan\)](#).

3 Transportation and Storage

3.1 Transportation Requirements

General Requirements

- Be cautious to prevent injury when moving heavy objects.



< 18 kg
(< 40 lbs)



18–32 kg
(40–70 lbs)



32–55 kg
(70–121 lbs)

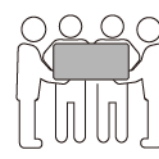

55–68 kg
(121–150 lbs)



> 68 kg
(> 150 lbs)

CZ0000110

- If multiple persons need to move a heavy object together, determine the manpower and work division with consideration of height and other conditions to ensure that the weight is equally distributed.
- If two persons or more move a heavy object together, ensure that the object is lifted and landed simultaneously and moved at a uniform pace under the supervision of one person.
- Wear personal protective gears such as protective gloves and shoes when manually moving the equipment.
- To move an object by hand, approach to the object, squat down, and then lift the object gently and stably by the force of the legs instead of your back. Do not lift it suddenly or turn your body around.
- Move or lift the equipment by holding its handles or lower edges. Do not hold the handles of modules that are installed in the equipment.
- Do not quickly lift a heavy object above your waist. Place the object on a workbench that is half-waist high or any other appropriate place, adjust the positions of your palms, and then lift it.
- Move a heavy object stably with balanced force at an even and low speed. Put down the object stably and slowly to prevent any collision or drop from scratching the surface of the equipment or damaging the components and cables.

- When moving a heavy object, be aware of the workbench, slope, staircase, and slippery places. When moving a heavy object through a door, ensure that the door is wide enough to move the object and avoid bumping or injury.
- When transferring a heavy object, move your feet instead of turning your waist around. When lifting and transferring a heavy object, ensure that your feet point to the target direction of movement.
- When transporting the equipment using a pallet truck or forklift, ensure that the tynes are properly positioned so that the equipment does not topple. Before moving the equipment, secure it to the pallet truck or forklift using ropes. When moving the equipment, assign dedicated personnel to take care of it.
- The tilt angle of the ESS shall meet the requirements shown in the figure: $\alpha \leq 5^\circ$.

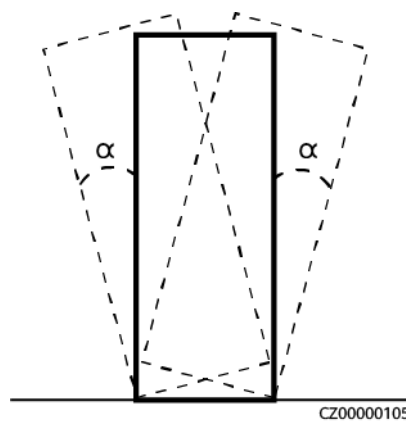

- When moving and transporting an air conditioner, keep it upright and do not place it horizontally or upside down. If the package of the air conditioner is damaged or the tilt indicator on the package changes color, contact the Company's service engineers.

Transportation Requirements

DANGER

Load or unload batteries with caution. Otherwise, the batteries may be short-circuited or damaged (such as leakage and crack), catch fire, or explode.

WARNING

Do not move a battery by holding its terminals, bolts, or cables. Otherwise, the battery may be damaged.

Keep batteries in the correct direction during transportation. They must not be placed upside down or tilted, and must be protected against falling down, mechanical impact, rains, snows, and falling into water during transportation.

- According to the UN *Recommendations on the Transport of Dangerous Goods: Model Regulations* (also referred to as TDG or UN Orange Book),

batteries belong to class 9 dangerous goods and shall pass the related tests required in Part III Subsection 38.3 of the UN *Recommendations on the Transport of Dangerous Goods: Manual of Tests and Criteria*.

- Transportation and storage service providers must have the qualifications for dangerous goods operations required by local laws, regulations, and standards. Rigid box trucks shall be used for transportation and pickup trucks are prohibited.
- Comply with the latest international and national rules on the transportation and storage of dangerous goods, including but not limited to the *International Maritime Dangerous Goods Code (IMDG Code)*, *Agreement concerning the International Carriage of Dangerous Goods by Road (ADR)*, and China's transportation industry standards (JT/T 617) *Regulations concerning road transportation of dangerous goods*, as well as the requirements of the transportation regulatory authorities in the countries of departure, route, and destination. Before transportation and storage, properly pack, label, and mark products according to the local laws, regulations, and standards, and complete related product and packaging tests.
- Choose sea or roads in good conditions for transportation. Do not transport the equipment by railway or air. Avoid tilt or jolt during transportation.
- Monitor the entire transportation process.
- Vehicles for road transport shall meet the load bearing capacity requirements: The weight of a single ESS is about 30 t.
- The speed limit for road transport is 80 km/h on flat roads and 60 km/h on rough roads. In the case of any conflict, comply with local traffic laws and regulations.
- Stacking requirements at ports and during shipping: A maximum of five ESSs shall be permitted to be stacked.
- Before transportation, ensure that the ESS container is intact, the cabin doors are closed and locked, no foreign matter protrudes from the container, and there is no smell of smoke or burning. Otherwise, do not transport the ESS.
- Before transportation, make a compliant and accurate declaration. Ensure that the battery packaging, labels, and markings are intact and there is no abnormal smell, leakage, smoke, or fire. Otherwise, the batteries must not be transported.
- Handle the ESS with care during loading, unloading, and transportation and moisture-proof measures must be in place. The product specifications upon delivery may be affected subsequently by the environment conditions, such as temperature, transportation, and storage.
- The packing case must be solid and strong. Handle the packages with care and take moisture-proof measures during loading, transportation, and unloading. Do not place the packages on one side or upside down. Bind the packages securely to avoid displacement. Ensure that the dangerous goods labels are visible.
- Exercise caution when moving batteries to prevent bumping and ensure personal safety.
- Unless otherwise specified, dangerous goods must not be mixed with goods containing food, medicine, animal feed, or their additives in the same vehicle or container.

- If the local laws, regulations, and standards allow the mixed transportation of specified different dangerous goods and that of dangerous goods and common goods, the dangerous goods shall be isolated according to the local laws, regulations, and standards. If there is no specific local requirement, refer to the following requirements for isolation when dangerous goods and common goods are in the same vehicle or container:
 - Use a spacer that is as high as the packages.
 - Keep a distance of at least 0.8 m around.
- Before transporting a faulty battery (with scorch, leakage, bulge, or water intrusion), insulate its positive and negative terminals, pack it, and place it in an insulated explosion-proof box as soon as possible. Record information such as the site name, address, time, and fault symptom on the box.
- When transporting faulty batteries, avoid approaching flammable material storage areas, residential areas, or other densely populated places, such as mass transit facilities or elevators.

3.2 Storage Requirements

General Requirements

- Proof that the product is stored according to the requirements must be available, such as temperature and humidity log data, storage environment photos, and inspection reports.
- The storage environment must be clean and dry. The product must be protected against rain and water.
- The air must not contain corrosive or flammable gases.
- Do not tilt the product or place it upside down.
- If equipment except battery packs has been stored for more than two years, it must be checked and tested by professionals before use.

ESS Storage Requirements

- Do not stack the ESSs.
- The ground for (long-term or temporary) storage is level, and the height tolerance of the ground in contact with the container is less than 5 mm.
- The container doors are closed tightly.
- Storage temperature: -40°C to $+60^{\circ}\text{C}$; relative humidity: 5%–95% RH
- Place desiccant in control unit cabins and battery cabins for long-term storage.
- The main power loop of the ESS must be disconnected during onsite storage. It is recommended that the auxiliary power loop be powered on to ensure that the monitoring system works properly.

Battery Storage Requirements





WARNING

- Ensure that batteries are stored in a dry, clean, and ventilated indoor environment that is free from sources of strong infrared or other radiations, organic solvents, corrosive gases, and conductive metal dust. Do not expose batteries to direct sunlight or rain and keep them far away from sources of heat and ignition.
- If a battery is faulty (with scorch, leakage, bulge, or water intrusion), move it to a dangerous goods warehouse for separate storage. The distance between the battery and any combustible materials must be at least 3 m. The battery must be scrapped as soon as possible.
- Place batteries correctly according to the signs on the packing case during storage. Do not place batteries upside down, lay them on one side, or tilt them. Stack batteries in accordance with the stacking requirements on the packing cases.
- Store batteries in a separate place. Do not store batteries together with other devices. Do not stack batteries too high. The site must be equipped with qualified fire fighting facilities, such as fire sand and fire extinguishers.
- After batteries are powered off, static power consumption and self-discharge loss may occur in internal modules, which may cause battery damage due to overdischarge. Do not store batteries in low SOC and charge batteries in a timely manner. Permanent battery faults caused by delayed charge are not covered by the warranty. Storing the batteries in low SOC occurs in scenarios including but not limited to the following:
 - The power cables or signal cables are not connected.
 - The batteries cannot be charged due to a system fault after discharge.
 - The batteries cannot be charged due to incorrect configurations in the system.
 - The batteries cannot be charged due to long-term mains failure.
 - The batteries cannot be charged because the switch of the Smart Rack Controller, Smart PCS, or main loop component is off.

CAUTION

It is recommended that batteries be used soon after being deployed onsite. Batteries that have been stored for an extended period shall be charged periodically. Otherwise, they may be damaged.

-
- Packaging label description

Label	Description
	<p>This way up: The package shall be vertically oriented during transport and storage.</p>
	<p>Fragile: The package contains fragile objects and shall be handled with care.</p>
	<p>Keep dry: The package shall be kept away from rain.</p>
	<p>Stacking limit by number: The packages shall not be vertically stacked beyond the specified number. The actual label may vary.</p>

- The storage environment requirements are as follows:
 - Ambient temperature: -40°C to $+60^{\circ}\text{C}$ (0°C to 30°C are recommended. If batteries are stored at a temperature higher than 40°C for extended periods, the battery performance and service life may be deteriorated.)
 - Relative humidity: 5%–95% RH (recommended: about 45% RH)
 - Dry, clean, and well-ventilated
 - Away from corrosive organic solvents and gases
 - Away from direct sunlight
 - At least 2 m away from heat sources
- The batteries in storage must be disconnected from external devices. The indicators (if any) on the batteries must be off.
- The storage duration starts from the latest charge time labeled on the battery package. If a battery is qualified after charge, update the latest charge time (recommended format: YYYY-MM-DD HH:MM) and the next charge time (Next charge time = Latest charge time + Charge interval) on the label.
- The following table lists the maximum charge intervals for batteries delivered separately. Charge the batteries promptly and calibrate the SOC to at least 50%. Otherwise, the battery performance and service life may be deteriorated.

Storage Temperature (T)	Maximum Charge Interval ^a
$-40^{\circ}\text{C} < T \leq +30^{\circ}\text{C}$	15 months
$30^{\circ}\text{C} < T \leq 40^{\circ}\text{C}$	11 months
$40^{\circ}\text{C} < T < 60^{\circ}\text{C}$	7 months
Note a: The interval starts from the latest charge time labeled on the battery package.	

- The following table lists the maximum total storage and transportation time for batteries delivered with the ESS. Charge the batteries promptly and calibrate the SOC to at least 50%. Otherwise, the battery performance and service life may be deteriorated.

Storage Temperature (T)	Maximum Total Storage and Transportation Time ^a
$-40^{\circ}\text{C} < T \leq +30^{\circ}\text{C}$	11 months
$30^{\circ}\text{C} < T \leq 40^{\circ}\text{C}$	7 months
$40^{\circ}\text{C} < T < 60^{\circ}\text{C}$	3 months
Note a: The total time starts from the time when the product is shipped.	

- Do not unpack batteries. If charging is necessary, they must be charged by professionals as required and then returned to their original packaging after charging.
- The warehouse keeper shall collect battery storage information every month and periodically report the battery inventory information. The batteries in long-term storage shall be charged in a timely manner.

 **CAUTION**

- Only trained and qualified personnel are allowed to charge batteries. Wear insulated gloves and use dedicated insulated tools during the operation.
 - Observe onsite during charge and handle any exceptions in a timely manner.
 - If a battery experiences an abnormality such as bulging or smoking during charge, stop charging immediately and dispose of it.
-
- When stored in low SOC, the batteries must be charged within the maximum interval corresponding to the SOC when the batteries are powered off. If the batteries are not charged within the specified interval, they may be damaged due to overdischarge.

Power-Off SOC Before Storage	Maximum Charge Interval
SOC \geq 50%	Refer to the charge intervals for batteries delivered separately.
5% \leq SOC < 50%	20 days
SOC < 5%	48 hours

- For details about how to charge batteries, see [3.3 Charging Requirements for a Single Battery](#).
- If batteries have been stored for longer than allowed, promptly report the event to the person in charge.
- Ensure that batteries are delivered based on the "first in, first out" rule.
- Handle batteries with caution to avoid damage.

Storage Requirements for Fire Suppression Equipment

- At room temperature (about 25°C), charge the backup battery of the extinguishant control panel at least once every six months. The charge interval is halved for every 10°C increase in temperature.
- When the fire suppression equipment is stored as spare parts, the ambient temperature shall range from 0°C to 50°C and the humidity shall be less than or equal to 95% RH.

Storage Requirements for a Smart Rack Controller

If a spare Smart Rack Controller will not be used immediately, store it according to the following requirements:

- Do not remove the packaging. Check the packaging regularly (recommended: once every three months). Replace any packing materials that become damaged during storage. If the Smart Rack Controller is unpacked but will not be used immediately, put it back to the original packaging with the desiccant, and seal with tape.
- Storage temperature: -40°C to +70°C; relative humidity: 5%–95% RH
- Stack Smart Rack Controllers with caution to prevent them from falling over, resulting in personal injury or equipment damage.

3.3 Charging Requirements for a Single Battery

Material Delivery Check

There must be a battery charge label on the packing case. The charge label must specify the latest charge time and the next charge time.

Conditions for Determining Overdue Storage

- Do not store batteries for extended periods.

- The following table lists the maximum charge intervals for batteries delivered separately. Charge the batteries promptly and calibrate the SOC to at least 50%. Otherwise, the battery performance and service life may be deteriorated.

Storage Temperature (T)	Maximum Charge Interval ^a
$-40^{\circ}\text{C} < T \leq +30^{\circ}\text{C}$	15 months
$30^{\circ}\text{C} < T \leq 40^{\circ}\text{C}$	11 months
$40^{\circ}\text{C} < T < 60^{\circ}\text{C}$	7 months
Note a: The interval starts from the latest charge time labeled on the battery package.	

- The following table lists the maximum total storage and transportation time for batteries delivered with the ESS. Charge the batteries promptly and calibrate the SOC to at least 50%. Otherwise, the battery performance and service life may be deteriorated.

Storage Temperature (T)	Maximum Total Storage and Transportation Time ^a
$-40^{\circ}\text{C} < T \leq +30^{\circ}\text{C}$	11 months
$30^{\circ}\text{C} < T \leq 40^{\circ}\text{C}$	7 months
$40^{\circ}\text{C} < T < 60^{\circ}\text{C}$	3 months
Note a: The total time starts from the time when the product is shipped.	

- If batteries have been stored for longer than allowed, promptly report the event to the person in charge.
- Dispose of deformed, damaged, or leaking batteries directly irrespective of how long they have been stored.
- The storage duration starts from the latest charge time labeled on the battery package. If a battery is qualified after charge, update the latest charge time (recommended format: YYYY-MM-DD HH:MM) and the next charge time (Next charge time = Latest charge time + Charge interval) on the label.
- Batteries can be charged for a maximum of three times during storage. Dispose of batteries if the maximum charge times are exceeded.
- You can obtain the battery production completion time by querying the delivery record based on the battery pack serial number (SN) or consulting the Company's service engineers.

Preparing Charging Devices

- Multimeter
- Clamp meter
- Insulated torque socket wrench
- Charger

Inspection Before Charge

1. Before charging a battery, you need to check its appearance. Charge the qualified battery or dispose of the unqualified one.
2. The battery is qualified if it is free from the following symptoms:
 - Deformation
 - Shell damage
 - Leakage
3. Check that the accessories are complete based on the packing list delivered with the charger.

Full Charge Strategy

The charging ambient temperature ranges from 15°C to 40°C.

Charge and Discharge Current (Unit: Ampere)	Charging Duration (Excluding Equalization)
20	24 hours (fully discharge the battery and then charge the battery to 50% SOC)
40 ^[1]	12 hours (fully discharge the battery and then charge the battery to 50% SOC)
Note 1: In customized mode, use the AC 220 V/20 A (6 mm ²) power cable delivered with the charger.	

Charging Procedure

NOTE

Prepare the battery qualified for charge.

- Step 1** Connect the communications port on the charger to the COM-2 and 48V-2 ports on the battery using the CAN communications cable (48 V) delivered with the charger.
- Step 2** Connect the positive and negative cable ports on the charger to the positive and negative ports on the battery using the positive and negative DC input power cables delivered with the charger.
- Step 3** Connect the AC INPUT port on the charger to the utility power source using the power cable delivered with the charger.
- Step 4** Turn on the AC circuit breaker of the charger.
- Step 5** Turn on the DC circuit breaker of the charger.
- Step 6** Operate the charger according to its manual.

Step 7 After the discharge and charge are complete, wait until the fan in the charger keeps running for about 5 minutes to dissipate the residual heat, turn off the AC and DC circuit breakers, and remove the cables.

----End

4 Site Requirements

4.1 Site Selection Requirements

NOTICE

Refer to the GB 51048 *Design code for electrochemical energy storage station*, NFPA 855 *Standard for the Installation of Stationary Energy Storage Systems*, and local laws and regulations.

The site selection requirements for the ESS are as follows:

- The ESS applies only to outdoor scenarios and must not be deployed indoors.
- The horizontal level of the installation site shall be above the highest water level of that area in history and at least 300 mm above the ground. The site must not be located in a low-lying land.
- No obstacle shall be above the ESS. For example, the ESS must not be installed under a parking shed and PV modules must not be installed on the top of the ESS.
- For safety purposes, keep safety distances between the ESS and surrounding buildings and facilities.
 - The distance between the ESS and residential buildings must be greater than or equal to 12 m, and the distance between the ESS and densely populated buildings such as schools and hospitals must be greater than 30.5 m.
 - The distance between the ESS and production buildings in commercial and industrial scenarios must be greater than or equal to 12 m. If the distance does not meet the requirement, fire walls shall be installed between the ESS and production buildings. The fire walls shall have a 3-hour or higher fire resistance rating and shall extend 1.5 m above and 1.5 m beyond the physical boundary of the ESS. In addition, the clearance requirements for equipment transportation, installation, and maintenance shall be considered.
- There must be no vegetation, especially flammable plants within 3 m of the ESS or the site to protect the ESS from possible fires.

- It is recommended that outdoor open electrochemical energy storage plants be equipped with fences and walls. The external walls of an electrochemical energy storage plant deployed in a power plant or power transformation and distribution station shall be permitted to serve as the enclosure and isolation walls.
- The safety distances between the ESS and buildings shall comply with local fire protection regulations or standards.
- The ESS and the site must be in an environment free from explosion risks.
- Transportation to the site shall be convenient and fire suppression facilities shall be reliable.

 **NOTE**

- When installing, commissioning, and operating the ESS, ensure that at least two gas fire extinguishers are provided near each unit to ensure fire safety.
- The distance between the exhaust device of an ESS and the heating and ventilation vents, air intake vents of air conditioners, windows, doors, unloading platforms, and fire sources of other buildings or facilities must be greater than 4.6 m.
- Reserve sockets for the water fire suppression system at the ESS site.
- Outdoor fire hydrants shall be installed around the plant. The distance between fire hydrants shall be less than or equal to 60 m. The number of outdoor fire hydrants shall be calculated based on the flow rate and protection radius of fire hydrants. The maximum protection radius shall be less than or equal to 150 m, and the flow rate shall be greater than or equal to 15 L/s.
- The site area must meet the requirements and there shall be space for capacity expansion.
- The site shall be in a well-ventilated place.
- The ESS shall not be installed in salt-affected or polluted areas because this will cause corrosion. The ESS shall be used in the following or better environments:
 - Outdoor environment more than 2000 m away from the coast. You are advised not to use the ESS in an area 500 m to 2000 m away from the coast. (If you need to use it, confirm with the vendor or the Company's engineers.) Do not use the ESS in an area less than 500 m away from the coast.
 - More than 1500–3000 m away from heavy pollution sources such as smelteries, coal mines, and thermal power plants
 - More than 1000–2000 m away from medium pollution sources such as chemical, rubber, and electroplating industries
 - More than 500–1000 m away from light pollution sources such as packing houses, tanneries, boiler rooms, slaughterhouses, landfill sites, and sewage treatment plants

 **NOTE**

You are advised to select another site if the safety distance for a site cannot meet the requirements of relevant national standards.

Do not select the sites that are not recommended by industry standards and regulations, including but not limited to the following areas:

- Areas with sources of strong vibration, loud noises, and strong electromagnetic interference

- Areas with dust, oil fumes, harmful gases, corrosive gases, etc.
- Areas with corrosive, flammable, and explosive materials
- Areas with existing underground facilities
- Areas with adverse geological conditions such as rubbery soil and soft soil layer, or prone to waterlogging and land subsidence
- Under a reservoir, water landscape, and water room

 **NOTE**

- If areas prone to waterlogging cannot be avoided, install water blocking and drainage facilities or raise the ground.
- Cable trenches shall not be used for drainage. Fire retardant sealing shall be implemented at cable holes (such as holes through partition walls and floors).
- Areas prone to earthquakes and with seismic fortification intensity higher than 9
- Areas prone to debris flow, landslide, quicksand, karst caves, and other direct hazards
- Areas within the mining land subsidence (dislocation) zone
- Areas within the scope of blasting hazard
- Areas prone to flood due to a dam or levee failure
- Protection areas for important water supply sources
- Protection areas for historic relics
- Populated areas, high-rise buildings, and underground buildings
- Intersections and busy roads of urban main roads

Requirements for flood and waterlogging prevention in site selection:

- The site design elevation of a large-scale electrochemical energy storage system (power ≥ 100 MW) shall be higher than the flood level with a probability of 1% or the historical highest waterlogging level.
- The site design elevation of a medium- or small-scale electrochemical energy storage system (power < 100 MW) shall be higher than the flood level with a probability of 2% or the historical highest waterlogging level.
- If the site design elevation cannot meet the preceding requirements, change the site location or take different flood and waterlogging prevention measures based on the site requirements.
- For energy storage plants prone to wind and waves from rivers, lakes, and seas, the elevation of flood prevention facilities shall consider the wind and wave height with a probability of 2% and an additional safety height of 0.5 m.
- When a large amount of catchment water flows into or passes through the site, it is recommended that side ditches or drainage ditches be built to drain water from the ground in an organized manner.

Security fencing:

It is recommended that physical walls or fences be used for isolation and protection in the energy storage equipment area. The fences shall be equipped with a door lock and the recommended fence height is greater than 2.2 m. Fire walls shall be permitted to be substituted for part or all of the fences, depending on the actual design plans.

4.2 Clearance Requirements

Clearance must be reserved for installation and O&M, as required in the following:

- Reserve at least 3000 mm clearance on the long sides and the control unit cabin side of the ESS, respectively.

NOTE

If the preceding safety distance requirements cannot be met, install fire walls between the ESSs. Ensure that the length and height of the fire walls extending above and beyond the physical boundary of the ESS installation meet the requirements in section "Site Selection Requirements".

- Set up a maintenance aisle around or on one side of the container. The net width of the aisle shall be no less than 1200 mm.
- The preceding clearance requirements are for reference only in terms of installation and O&M. The clearances must also comply with local fire control requirements.

4.3 Foundation Requirements

NOTE

The foundation layout design shall meet the space requirements for ESS installation and O&M. The design institute can contact local Huawei pre-sales engineers to obtain the drawings about the foundation.

Before installation, build concrete platforms and trenches on the selected ground. The foundation construction requirements are as follows:

- The dimensions of the foundation shall meet the installation and bearing requirements of the container.
- The foundation must be above the highest water level of the local area in history and at least 300 mm above the ground.
- The horizontal error between the foundation and the contact surface shall be less than 5 mm.
- The resistance of a bond shall be less than or equal to 0.1 ohms.
- The ESS uses bottom cabling. Cables shall be pre-buried under the control unit cabin.
- The inner diameter of the protective tube shall be greater than or equal to 1.5 times the outer diameter of the cable (including the protective layer).
- Construct drainage facilities based on the local geological conditions and municipal drainage requirements to ensure that no water will accumulate at the equipment foundation. The foundation construction must meet the local drainage requirements for the maximum historical rainfall. The drained water must be disposed of in accordance with local laws and regulations.
- After the foundation is excavated, prevent water from entering the foundation. If water enters the foundation, excavate and refill the affected parts.

- Cable trenches (if any) shall not be used for drainage. Fire retardant sealing shall be implemented at cable holes (such as holes through partition walls and floors).

Table 4-1 Check items

No.	Check Item	Acceptance Criteria
1	Cabling space at the bottom	<ul style="list-style-type: none"> • If no maintenance space at the bottom is required, it is recommended that the cabling space at the bottom of the container be greater than or equal to 1.1 m. • If maintenance space at the bottom is required, it is recommended that the cabling space at the bottom of the container be greater than or equal to 1.3 m.
2	Cable	<ul style="list-style-type: none"> • The bending radius of a cable is greater than or equal to 15 times the cable diameter. • The voltage drop of the farthest loop does not exceed 5%. • The sensitivity, voltage level, and thermal stability of the cables meet the local design specifications.

Figure 4-1 Foundation diagram

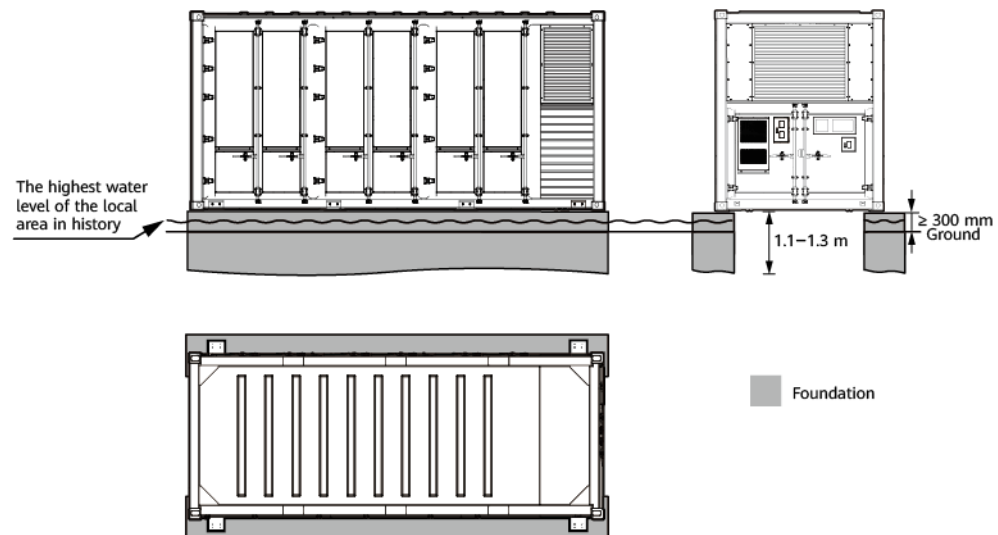

IB04W00103

5 Installation

5.1 Installation Preparations

5.1.1 Preparing Tools





 NOTE





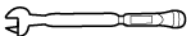





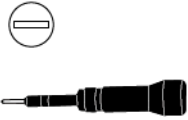
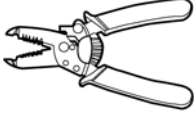
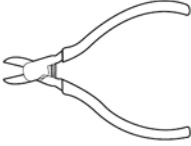

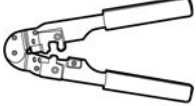
- The tools shown in the figures are for reference only.
- The tool table may not list out some tools required onsite. Onsite installation personnel and the customer need to prepare the tools based on site requirements.

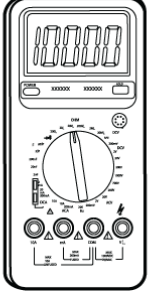

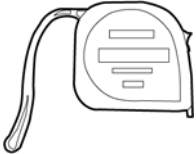

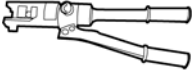



Installation Tools

 CAUTION

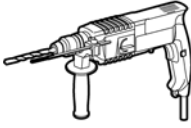

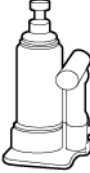

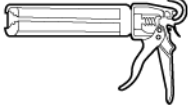



Tools such as socket wrenches, torque wrenches, and screwdrivers must be insulated tools.

			
Adjustable torque wrench	Insulated torque socket wrench (including an extension bar)	Insulated torque socket wrench (including an extended socket)	Phillips insulated torque screwdriver

 <p>Flat-head insulated torque screwdriver</p>	 <p>Wire strippers</p>	 <p>Diagonal pliers</p>	 <p>Utility knife</p>
 <p>Cable cutter</p>	 <p>RJ45 crimping tool</p>	 <p>Vacuum cleaner</p>	 <p>Multimeter DC voltage measurement range ≥ 1500 V DC</p>
 <p>Marker</p>	 <p>Steel measuring tape</p>	 <p>Digital or bubble level</p>	 <p>Hydraulic pliers</p>
 <p>Heat shrink tubing</p>	 <p>Heat gun</p>	 <p>Cable tie</p>	 <p>Insulated ladder</p>

 <p>Crane</p>	 <p>Steel wire rope sling and shackle</p>	 <p>Rubber mallet</p>	 <p>Hammer drill</p>
 <p>Drill bit ($\Phi 14$ mm, $\Phi 16$ mm, and $\Phi 20$ mm)</p>	 <p>Fire alarm tester</p>	 <p>Jack</p>	 <p>Laser level</p>
 <p>Sealant gun</p>	 <p>Sealant</p>	<p>-</p>	<p>-</p>

Personal Protective Equipment (PPE)

 <p>Insulated gloves</p>	 <p>Protective gloves</p>	 <p>Safety goggles</p>	 <p>Dust mask</p>
 <p>Safety shoes</p>	 <p>Reflective vest</p>	 <p>Safety helmet</p>	 <p>Safety harness</p>

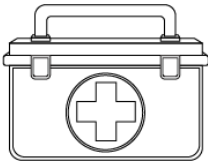
 Medical kit	-	-	-
--	---	---	---

5.1.2 Installation Environment Check

Check the site requirements one by one, and start installation only after all requirements are met. The Company will not be liable for any consequences in the case that the installation environment does not meet the requirements.

NOTICE

Mark the safe zone: Use red caution belts to delimit a safe zone, clean up obstacles in the safe zone, and place construction signs and warning signs in prominent positions.

5.2 Unpacking and Acceptance

NOTICE

- After placing the equipment in the installation position, unpack it with care to prevent scratches. Keep the equipment stable during unpacking.
- After unpacking, check whether the fastening components and removable components are loose. If they are loose, notify the carrier and manufacturer immediately.
- To prevent ingress of foreign objects, do not remove the blue protective film on the outdoor air conditioner unit of the ESS during storage. Remove the blue protective film before power-on and commissioning.

5.3 Installing the ESS

5.3.1 Determining the Installation Position of the ESS

Prerequisites

- The site requirements are met.
- Check and adjust the height of the concrete platforms to ensure that the height difference between the upper surfaces of all platforms does not exceed 5 mm.

NOTICE

Concrete platform levelness is critical to the ESS installation. Ensure that the concrete platforms meet requirements before installing the ESS.

- Determine the installation position and orientation of the ESS based on site conditions.

Procedure

- Step 1** Determine the reference points for installing the ESS on the concrete platforms. Mark the reference points using a marker.
- Step 2** On the basis of the reference points, mark the mounting positions for the four angle steel brackets of the ESS using an ink line and a long soft measuring tape.

NOTICE

When marking the positions for angle steel brackets, ensure that the four positions form a rectangle.

Figure 5-1 Positions of angle steel brackets

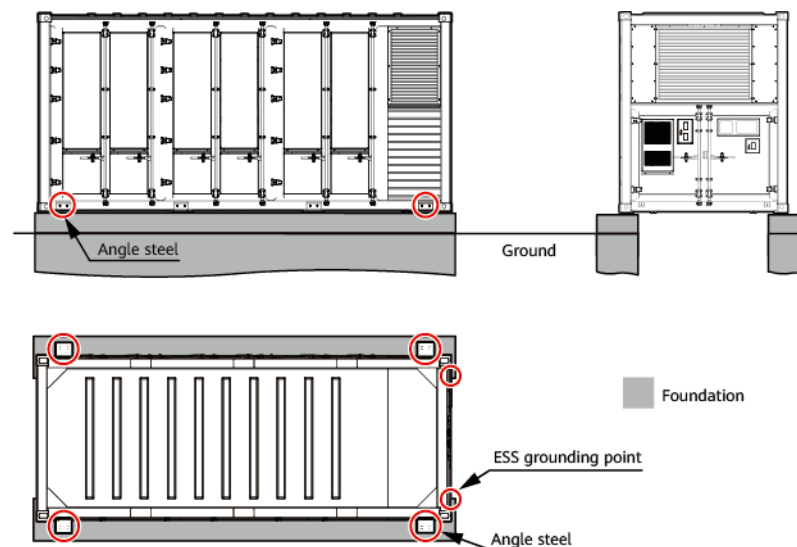

IB04W00103

----End

5.3.2 Hoisting the ESS

Prerequisites

- Before installing the equipment, check the ESS for damage, such as holes and cracks, and check the equipment model. If the appearance is abnormal or the equipment model is incorrect, contact your vendor.
- Select an appropriate crane based on standards of the crane company, and ask a professional to assess the crane onsite.

- The steel hoisting ropes are available.
- Before hoisting, ensure that the crane and hoisting ropes meet the load-bearing requirements.
- The doors of the ESS to be hoisted have been closed.
- It is recommended that the ESS be hoisted outdoors when the weather is clear and there is no wind.
- When installing or removing the hoisting equipment, do not drag it on the ESS to prevent scratches.

Hoisting Precautions

Table 5-1 Hoisting precautions

Stage	Precautions
Before hoisting	Ensure that the crane can hoist a load greater than 50 t and that the working radius is greater than or equal to 10 m. If the onsite environment does not meet the required working conditions, ask a professional to assess the conditions.
	Only trained and qualified personnel are allowed to perform hoisting operations.
	Check that hoisting tools are complete and in good condition.
	Ensure that the hoisting tools are secured to a load-bearing object or wall.
	Ensure that the crane and steel hoisting ropes provide the required load-bearing capacity.
	Ensure that all ESS doors are closed and locked.
	Ensure that the steel hoisting ropes are securely connected.
	It is recommended that the equipment be hoisted from left to right or from right to left.
During hoisting	Do not allow any unauthorized person to enter the hoisting areas and do not stand under the crane arm.
	Ensure that the crane is properly located and avoid long-distance hoisting.
	Ensure that the ESS is stable and the diagonal gradient of the ESS is less than or equal to 5 degrees.
	Ensure that the angle between two ropes is less than or equal to 90°.
	Lift and land the ESS slowly to prevent shock to the devices inside it.

Stage	Precautions
	Remove the hoisting ropes after ensuring that the ESS is placed evenly on the concrete platforms.
	Do not drag hoisting ropes and hoisting tools or bump hoisted objects against hard objects.

NOTE

- You are advised to level concrete platforms before hoisting the ESS.
- The levelness error of concrete platforms shall be less than or equal to 5 mm.
- Install the hoisting brackets and ropes, which shall be prepared by the customer.

Procedure

Step 1 Connect hoisting ropes, and hoist the ESS onto the concrete platforms.

NOTICE

The distances between the edge of the foundation and the four corners of the ESS shall be the same. The following figure uses one corner as an example.

Figure 5-2 Hoisting the ESS

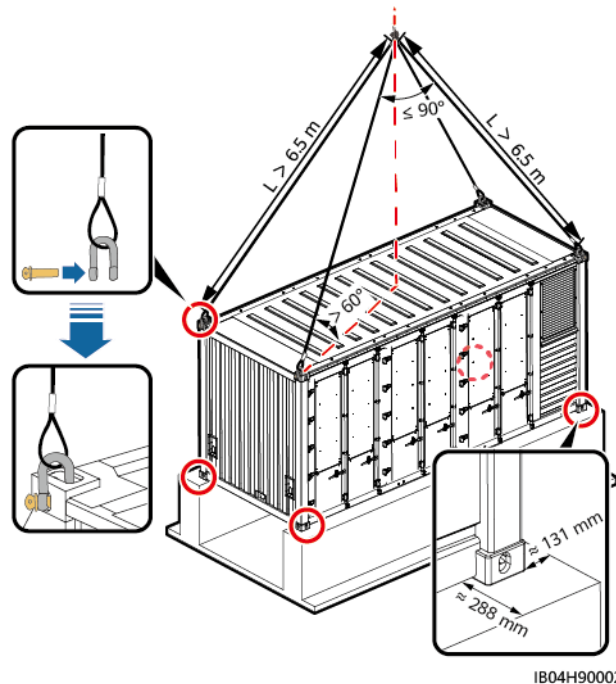

Step 2 Cut open the protective cover using a utility knife and remove the protective cover.

 **WARNING**

- When removing the protective cover, take protective measures for working at heights.
 - Do not remove the protective cover in bad weather conditions such as rain and snow.
-

----End

5.3.3 Opening the Doors of the ESS

 **CAUTION**

Do not open the container door in rainy, snowy, lightning, or dusty weather conditions.

NOTICE

Do not open the cabinet door when the humidity is high (relative humidity $\geq 80\%$ continuously), for example, on rainy days. If the cabinet door is open for 0.5 hour or longer when the humidity is high, manually perform forced dehumidification in off-grid and on/off-grid scenarios. Otherwise, the equipment may fail or the microgrid may collapse. You can check the running scenario on the SmartLogger WebUI. For details, see the *SmartLogger3000 User Manual*.

Perform dehumidification as follows:

1. Check that the auxiliary AC power supply to the ESS is powered on. In off-grid scenarios, the diesel generator or other external auxiliary power supply is used. In on/off-grid scenarios, the power grid supplies auxiliary power when available.
 2. Log in to the SmartLogger WebUI and choose **Monitoring > ESS > CMU > Running Param.**
 3. Choose **Temper And Hum > Control mode**, set **Control mode** to **Manual**, and submit the settings.
 4. Click **Starting up** and confirm the operation to start forced dehumidification. View the alarm information (ID is 3859) to check that the system has started forced dehumidification. The alarm will be automatically cleared after the dehumidification is complete, which takes about 10 to 20 minutes.
-

Step 1 Use a cable cutter to cut off the TSA approved lock on the door of the control unit cabin.

 **NOTE**

Only some models are equipped with the TSA approved lock. The actual products delivered may vary.

Figure 5-3 Positions of the safety lock and TSA approved lock

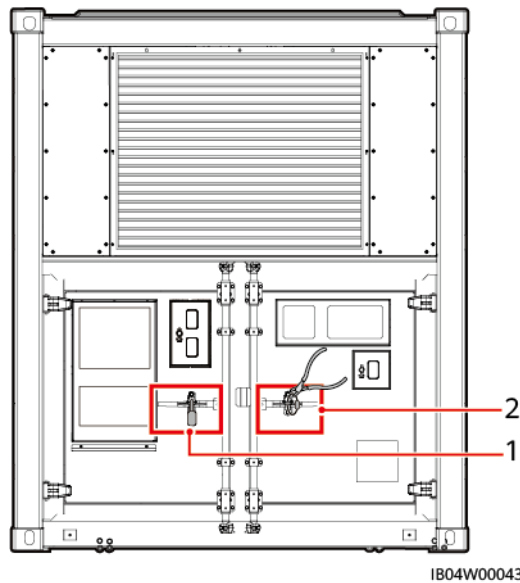

(1) Safety lock

(2) TSA approved lock

Step 2 Open the door, take the keys from the control unit cabin, and use the keys to open the safety lock.

Figure 5-4 Opening the door of the control unit cabin

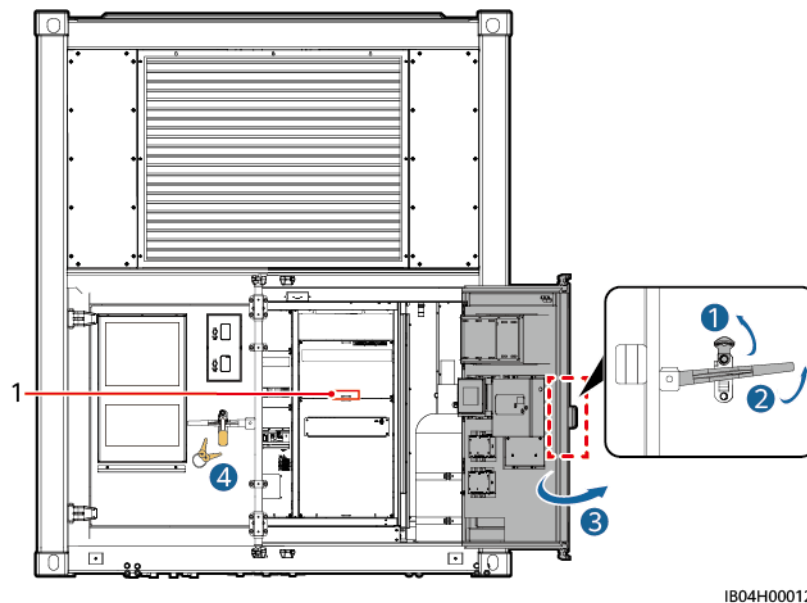

(1) Position of keys

Step 3 Use the keys to open the safety locks on the right handles of the battery cabins, and then open the doors of the battery cabins.

NOTE

- At least two persons are required to open the doors.
- After a door is opened, secure it using a door strut to prevent the door from moving.

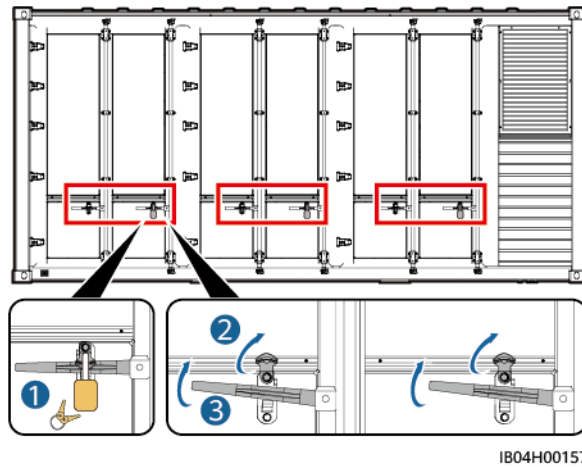

Step 4 Obtain the packing list and the quick guide. Check the materials against the packing list.

NOTE

- Lock the doors promptly and store the keys properly under the management of dedicated personnel.
- If any materials are missing, contact technical support.

----End

5.3.4 Grounding the ESS

Prerequisites

WARNING

Do not connect devices such as fuses and switches to ground cables.

CAUTION

The grounding shall comply with the local electrical safety regulations.

- The ESS is installed.
- The grounding requirements are clear.

Context

The requirements of ground cable are as follows:

Table 5-2 Ground cable description

Cable	Type	Cross-Sectional Area	Outer Diameter	Source
Ground cable	Single-core outdoor copper cable and M10/M12 OT/DT terminal	16-95 mm ²	10-32 mm	Prepared by the customer
The specifications of the ground cable are subject to this table or calculated according to IEC 60364-5-54.				

Connect Ground Cables

Step 1 Connect the main ground bar of the control unit cabin.

NOTICE

- The ground cable of the main ground bar in the control unit cabin must be connected.
- After connecting the ground cable of the main ground bar in the control unit cabin, close the cabin door in time.

Figure 5-5 Connecting the ground cable

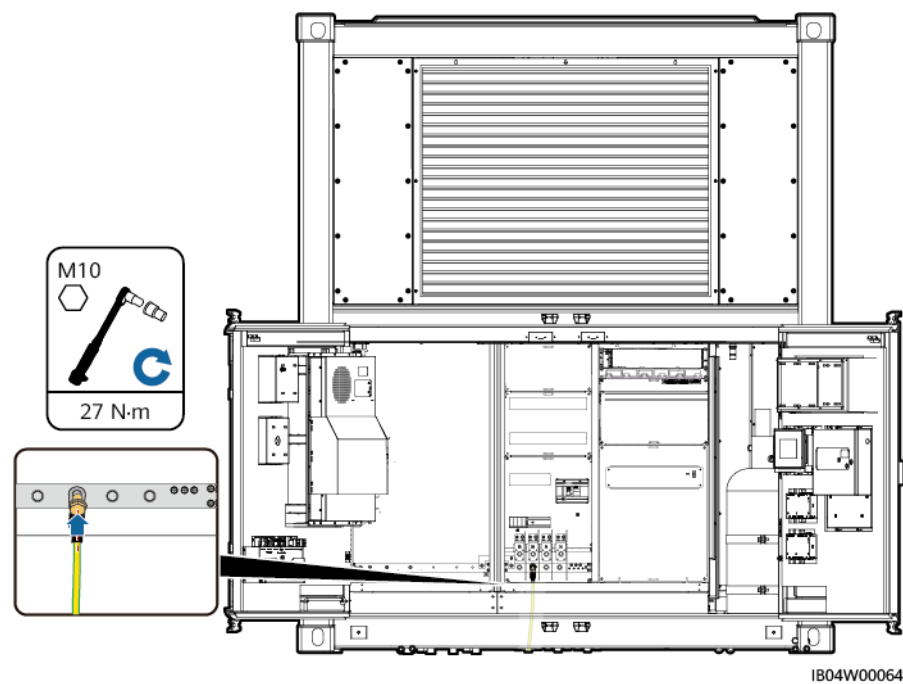
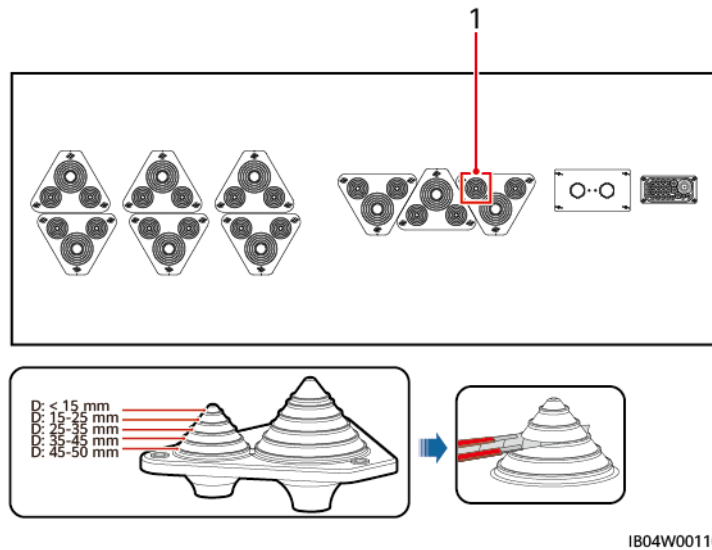

Figure 5-6 Position of the ground cable hole and pagoda connector cutting



(1) Ground cable hole

NOTE

The position for cutting the pagoda connector is for reference only. The actual cable usage may vary.

Step 2 Connect ground cables or ground lugs to the ground points of the ESS enclosure.

NOTE

There is one ground point on the left and right sides of the ESS. It is recommended that both ground points be grounded. Ground at least one ground point depending on the actual situation.

- Method 1: Connect ground cables to the ground points of the ESS using M12x30 stainless steel bolt assemblies. The ground cables can be routed through plastic-coated metal hoses based on site requirements.

Figure 5-7 Installing ground cables

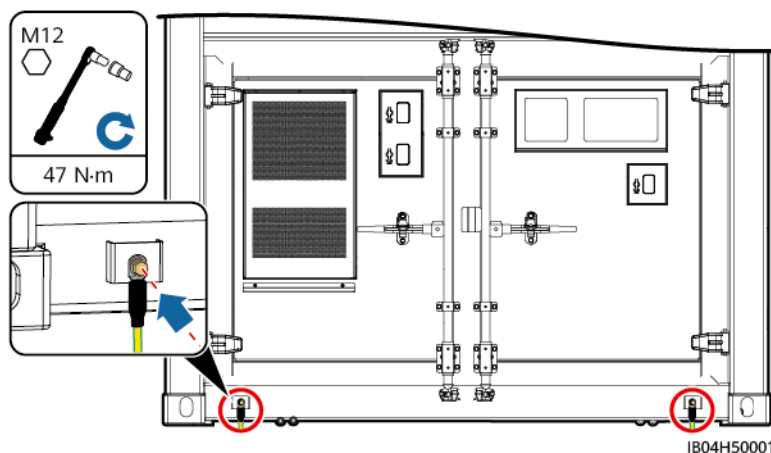

- Method 2: Connect ground lugs to the ESS ground points using M12x30 stainless steel bolt assemblies.

 NOTE

- Ground lug: Use ground lugs made of hot-dip zinc-coated flat steel sheet with a cross-sectional area of 40 mm x 4 mm, and leave 300 mm of each ground lug out of the concrete platform (same as the height between the foundation and the ground).
- Before the installation, remove the tinfoil from the ground lugs.

Figure 5-8 Installing ground lugs

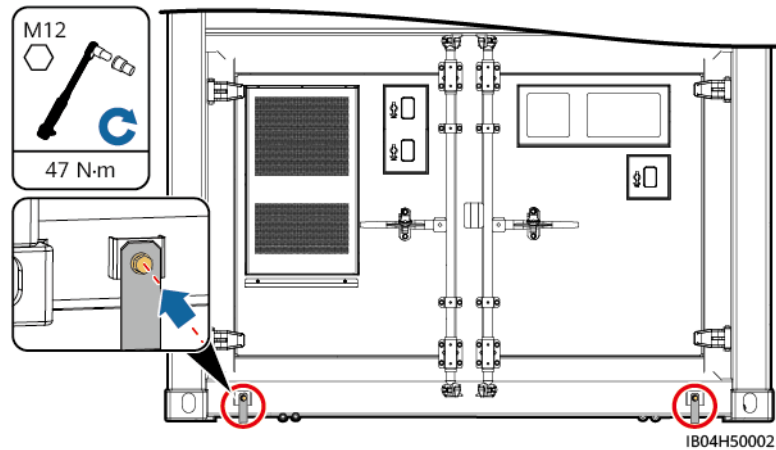

----End

5.3.5 Securing the ESS

Step 1 Open the door of the control unit cabin to get the angle steel brackets in the carton. Secure the ESS using four angle steel brackets.

 CAUTION

- To prevent the claw hammer from damaging the expansion bolt, use a wooden block between the claw hammer and the top of the bolt for protection.
- Ensure that the expansion bolts are tightened when securing the angle steel brackets to the base.

 NOTE

- There are four mounting holes where angle steel brackets contact the base. Mark all mounting holes.
- Each angle steel bracket must be secured by two mounting holes. It is recommended that the outer two mounting holes be used. If steel bars in a concrete base block the drill bit or when the position deviation occurs during the first drilling, use the inner mounting holes.

Figure 5-9 Securing the ESS

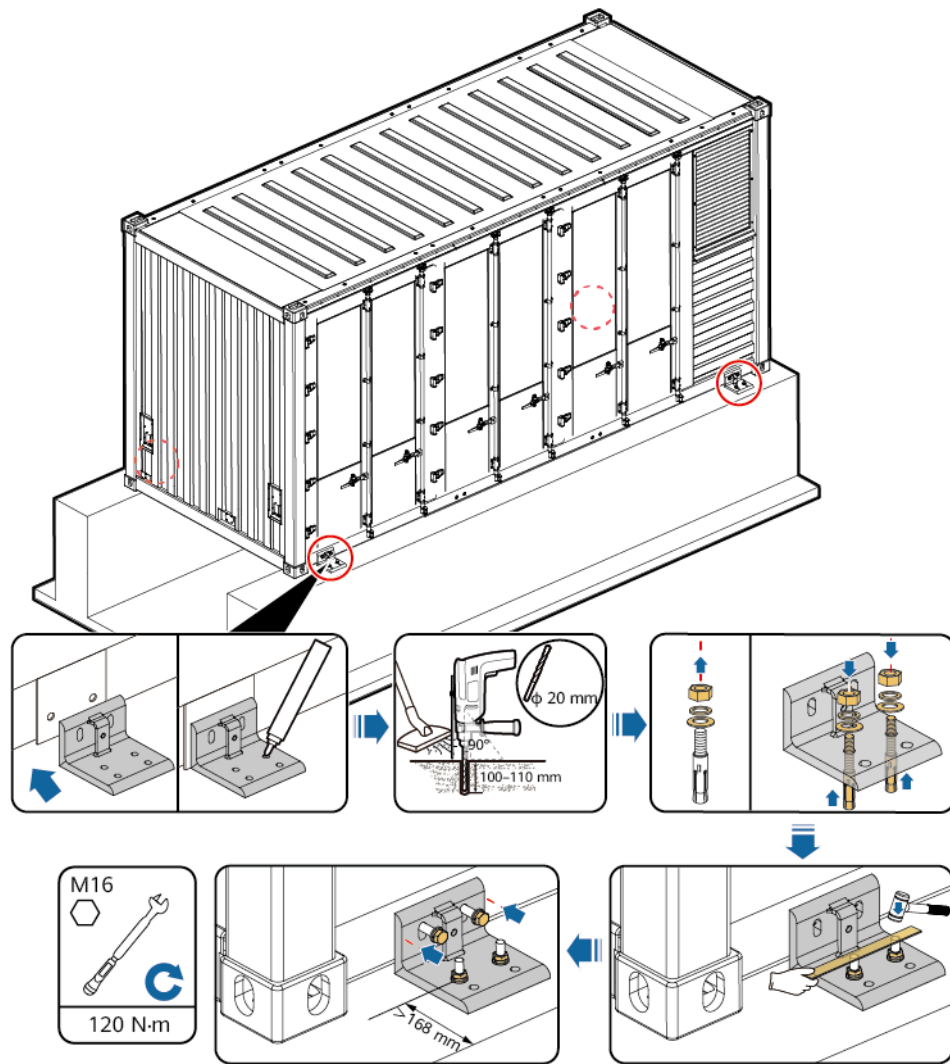

IB04H00009

----End

Follow-up Procedure

After the ESS is secured, verify the installation to ensure normal use of products and smooth subsequent installation.

Table 5-3 Verifying the installation

No.	Check Item	Check Method	Criteria
1	Bolts and nuts	Tighten the bolts and nuts again using a wrench with the same torque.	Bolts and nuts are tightened.

No.	Check Item	Check Method	Criteria
2	Check whether the doors of the ESS can be opened and closed properly.	Open and close the doors of the ESS.	All doors of the ESS can be opened and closed properly.

 NOTE

If the doors of the ESS cannot be opened or closed properly, see [11.1 How to Level the ESS When Doors Cannot Be Opened or Closed](#).

After the ESS is leveled, if the doors of the ESS can be opened but cannot be closed properly, slightly lift the lock bars and try to close the doors again.

5.3.6 (Optional) Anti-corrosion Measures on the Bottom of the ESS

After installing the ESS, you are advised to apply sealant at the gaps between the bottom of the ESS and the foundation to improve the anti-corrosion capability of the ESS.

 CAUTION

Do not perform anti-corrosion measures on the bottom of the ESS in harsh weather conditions such as lightning, rain, snow, sandstorm, and level 6 or stronger wind.

Prerequisites

Anti-corrosion materials and tools are available.

Table 5-4 Anti-corrosion materials and tools

Item	Type	Quantity	Source
Sealant	Silicone weatherproof sealant	About 4 L per ESS	Prepared by the customer
Sealant gun	Compatible with the sealant	1	Prepared by the customer
Utility knife	-	1	Prepared by the customer
Scraper	-	1	Prepared by the customer
Note: During construction, fill the sealant into the sealant gun according to the manufacturer's instructions.			

 **CAUTION**

Seal the remaining sealant promptly after use. Otherwise, the sealant will harden, decreasing its fluidity and adhesiveness. Do not use hardened sealant.

Procedure

Step 1 Clean the surfaces for applying sealant.

Clean the bottom of the ESS and the foundation surfaces. Ensure that the area for applying sealant is free from dust, water, oil stains, or other dirt.

Step 2 Apply sealant at the gaps between the bottom of the ESS and the foundation.

Construction method:

- The angle between the sealant gun and the foundation surface shall be 45 degrees.
- Press the sealant gun with even force and move it at a steady speed to ensure the sealant fills the gaps between the bottom of the ESS and the foundation evenly. If the gap is large, apply more sealant to ensure the sealing effect.
- Within 3 minutes after application, use a scraper to squeeze the sealant into the gaps and spread it evenly.

NOTE

- If the bottom of the control unit cabin and its opposite compartment is suspended and have no contact with the foundation, you do not need to apply sealant to this area. If the four edges at the bottom of the ESS are in contact with the foundation due to special reasons, apply sealant to the contact surfaces of the four edges.
- After applying the sealant, ensure that it fully adheres to the contact surfaces without air holes, gaps, breaks, light leaks, or water leaks. Clean up any excess sealant to maintain a full and neat finish.

Figure 5-10 Applying sealant

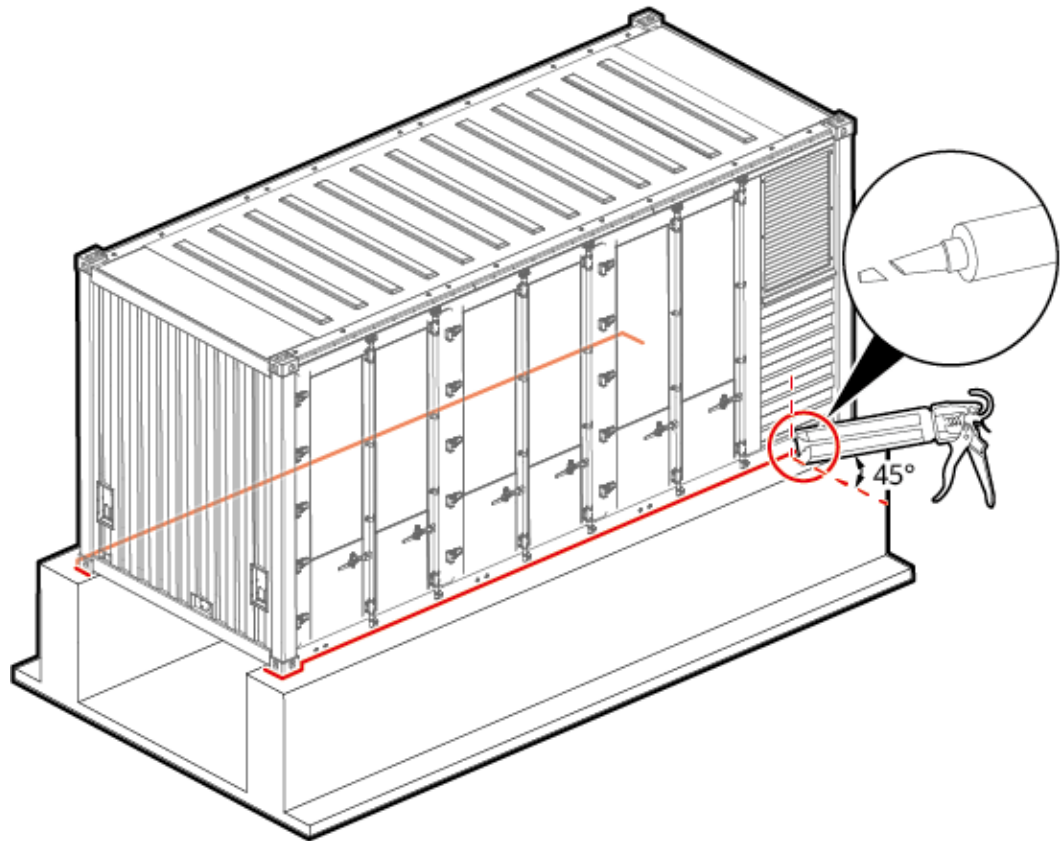

Step 3 Let the sealant sit to solidify.

After applying the sealant, let it sit for 4 hours to solidify.

CAUTION

During this time, avoid any actions that might cause displacement.

----End

5.4 Installing Components

CAUTION

- Ensure that the ESS is not powered on.
 - The installation personnel have taken safety protection measures, for example, wearing insulated gloves and shoes.
-

5.4.1 Installing Copper Bars Between Battery Packs

Prerequisites

The battery cabin door is open.

Procedure

Step 1 Take out the copper bars from the battery cabin.

Figure 5-11 Positions of the copper bars

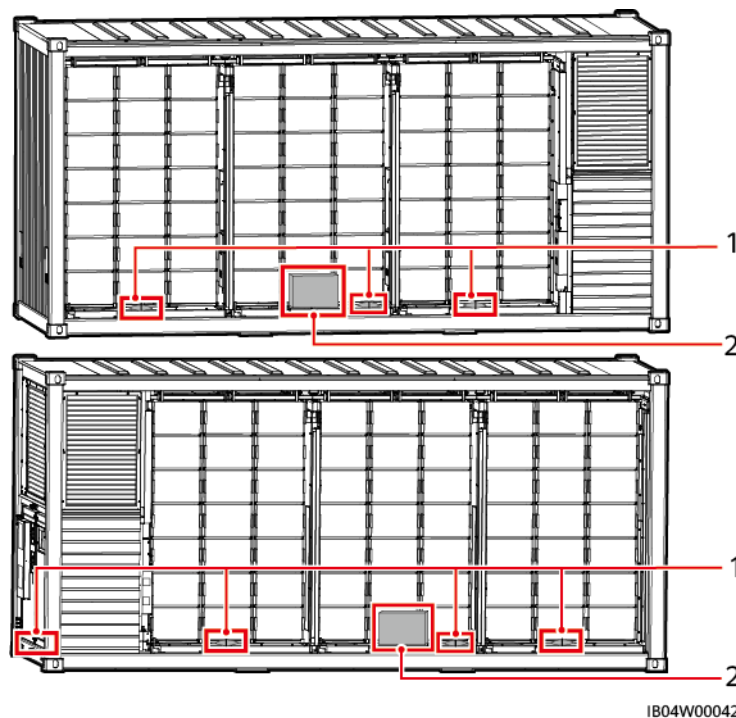

(1) Desiccant (Montmorillonite desiccant, 500 g/bag) (2) Copper bar

NOTE

- 25 bags of desiccants are required in total. Each battery cabin requires four bags, and each control unit cabin requires one bag.
- After cables are connected, do not remove the desiccants before power-on.
- If the ESS has been delivered for more than six months, replace the desiccants with new ones of the same specifications and amount (Montmorillonite desiccant, 500 g/bag).

Step 2 Press to open the cover on the right side of the battery pack.

Figure 5-12 Opening the cover on the right side of the battery pack

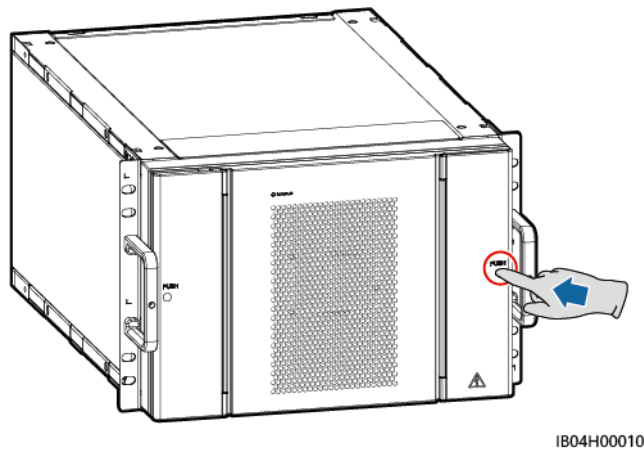

Step 3 Install copper bars between battery packs.

⚠ DANGER

- Do not smoke or have an open flame around batteries.
- The site must be equipped with qualified fire fighting facilities, such as fire sand and carbon dioxide fire extinguishers.
- Wear personal protective equipment and use dedicated insulated tools to avoid electric shocks or short circuits.

⚠ WARNING

Tighten the screws on copper bars or cables to the torque specified in this document. Periodically confirm whether the screws are tightened, check for rust, corrosion, or other foreign objects, and clean them up if any. Loose screw connections will result in excessive voltage drops and batteries may catch fire when the current is high.

⚠ CAUTION

When installing copper bar C, keep away from communications cables and fan power cables of battery packs to prevent cables from being squeezed.

NOTICE

- Use the copper bars delivered with the ESS. Do not use copper bars from ESSs of different models.
- When installing a nut, manually insert the nut into the screw plate, and then use a torque socket wrench to completely secure the nut in place. This prevents the screw thread from being stuck or stripped due to the deviation of the nut position.
- Preinstall nuts according to the recommended torque of 27 N·m.
- Verify the torque of the installed nuts using a torque socket wrench set to 27 N·m.
- Mark the nuts whose torque has been verified using a marker.
- Use an extension bar for the torque socket wrench.

NOTE

Three types of copper bars are included with the equipment and are identified by the silkscreens A, B, and C printed on the front.

Figure 5-13 Installing copper bars between battery packs

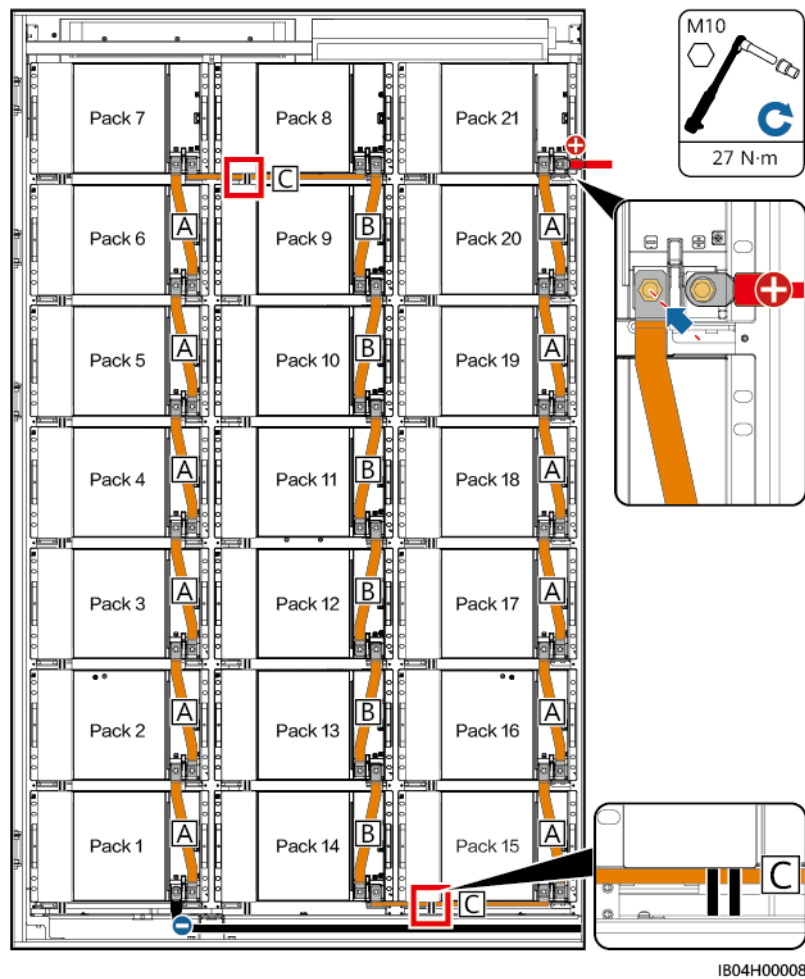

IB04H00008

 NOTE

For some models, each battery rack contains only 19 battery packs. Install copper bars by referring to the following figure.

Figure 5-14 Installing copper bars between battery packs

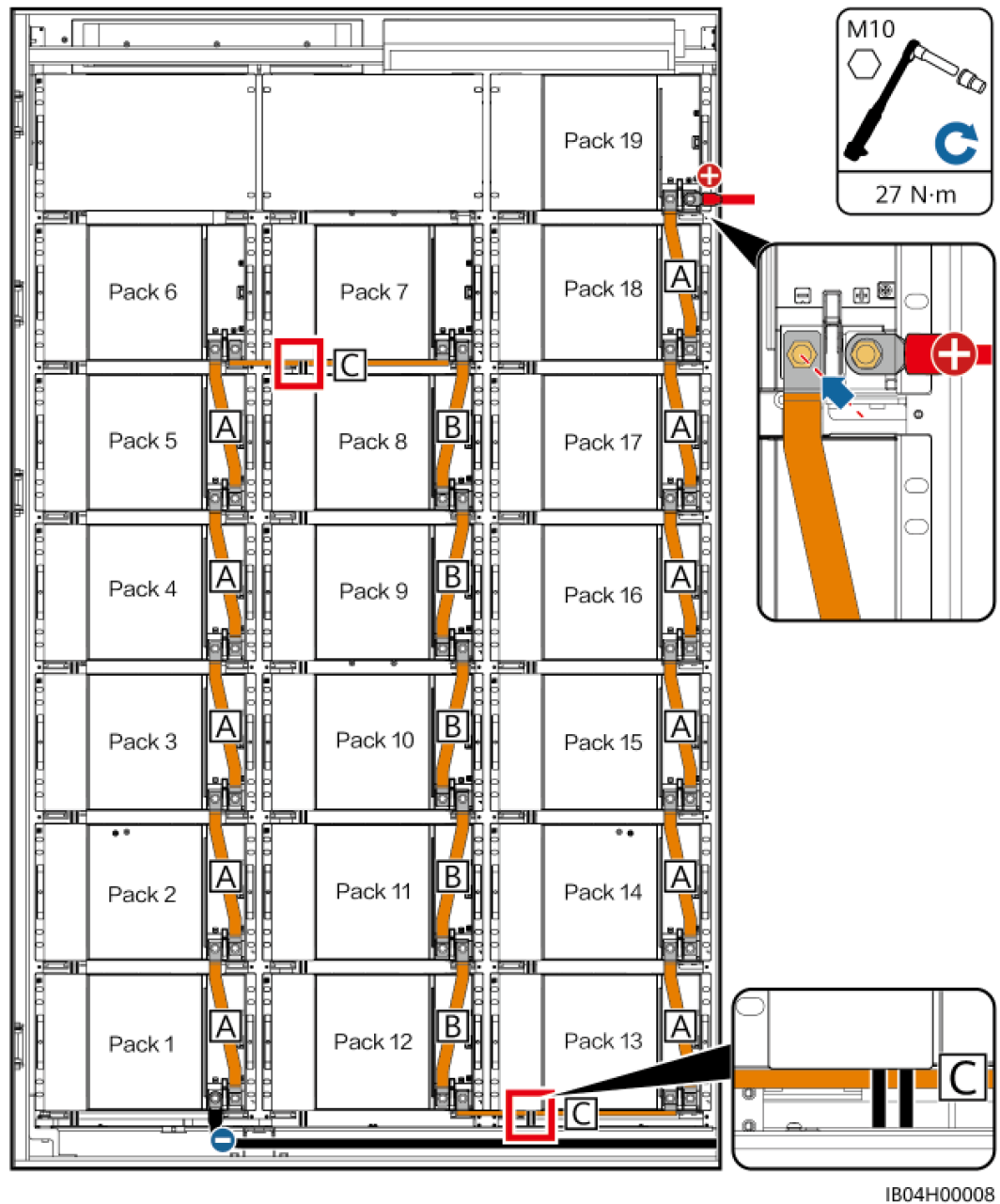

Step 4 Close the battery pack cover.

Step 5 Close the battery cabin door.

----End

5.4.2 Filling the Fire Cylinder with Extinguishant

 **CAUTION**

- This section only specifies the requirements on filling the fire cylinder with extinguishant. This operation shall be performed at a dedicated station.
 - Protect the fire cylinder from collision during transportation and installation.
-

 **NOTE**

This operation applies only to some fire cylinder models, including NCM38UFAA, P0009438, SPS020-MS-032B-EN, and 227M38UFAA.

- Step 1** Remove the hose connector from the ESS pipe using an adjustable torque wrench.
- Step 2** (Optional) Remove the extinguishant release hose from the high-pressure elbow using an adjustable torque wrench.
- Step 3** (Optional) Remove the high-pressure elbow from the changeable-diameter joint using an adjustable torque wrench.

 **NOTE**

- If there is no changeable-diameter joint, remove the high-pressure elbow directly from the fire cylinder.
- If there is no changeable-diameter joint and high-pressure elbow, remove the extinguishant release hose directly from the fire cylinder.

- Step 4** (Optional) Remove the changeable-diameter joint from the release vent using an adjustable torque wrench.

 **NOTE**

If there is no changeable-diameter joint on the fire cylinder, skip this step.

- Step 5** Install the safety cap of the release vent.
- Step 6** Remove the fire cylinder from the bracket.

Figure 5-15 Removal process diagram

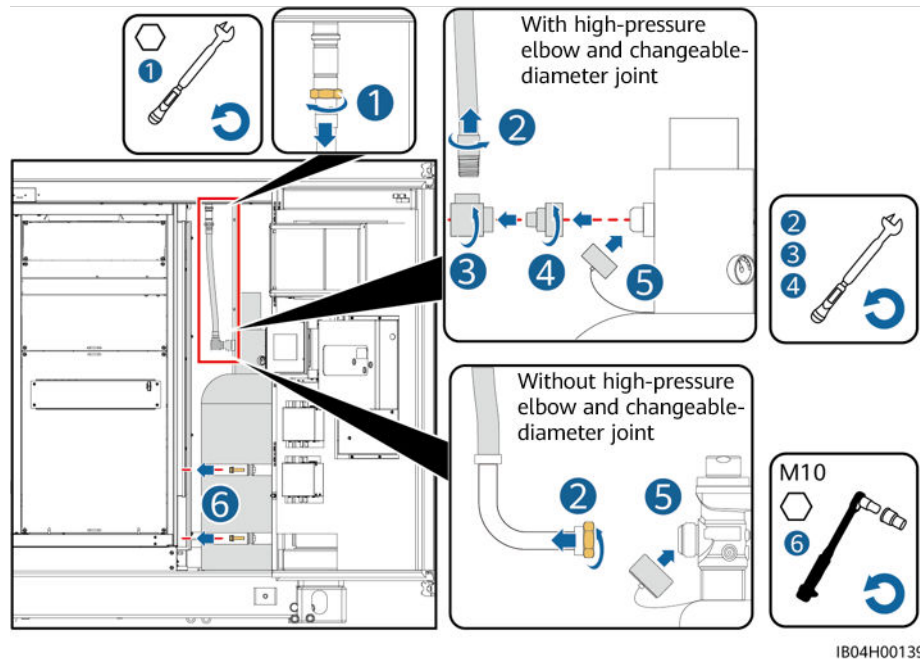

Step 7 Fill the fire cylinder with extinguishant.

Table 5-5 Requirements

Item	Specifications	
Extinguishant	Heptafluoropropane	Perfluorohexanone
Extinguishant weight	26–27 kg	31–32 kg
Purity requirement	≥ 99.9%	
Fire cylinder pressure (by filling nitrogen)	Refer to Pressure requirements under different ambient temperatures .	

Table 5-6 Pressure requirements at different ambient temperatures

Ambient Temperature (°C)	Pressure (Bar) of 227M38UFAA	Pressure (Bar) of SPS020-MS-032B-EN	Pressure (Bar) of P0009438	Pressure (Bar) of NCM38UFAA
0	20.2	16.92	22.1	20.2
5	21.4	18.85	22.8	21.4

Ambient Temperature (°C)	Pressure (Bar) of 227M38UFAA	Pressure (Bar) of SPS020-MS-032B-EN	Pressure (Bar) of P0009438	Pressure (Bar) of NCM38UFAA
10	22.6	20.77	23.5	22.6
15	23.8	22.69	24.3	23.8
20	25.0	24.62	25	25
25	26.2	26.54	25.8	26.2
30	27.4	28.46	26.5	27.4
35	28.6	30.38	27.3	28.6
40	29.8	32.31	28.1	29.8
45	31.0	34.23	28.8	31
50	32.2	36.15	29.5	32.2

Note: The actual cylinder pressure shall not be lower than 90% of the specified pressure at the corresponding ambient temperature.

Step 8 Install the fire cylinder.

Step 9 Remove the safety cap of the release vent.

Step 10 (Optional) Install the changeable-diameter joint to the release vent using an adjustable torque wrench.

Step 11 (Optional) Wrap eight turns of sealing tape around the external threads of the changeable-diameter joint, and install the high-pressure elbow to the changeable-diameter joint using an adjustable torque wrench.

Step 12 (Optional) Wrap eight turns of sealing tape around the external thread connector of the extinguishant release hose and install the extinguishant release hose to the high-pressure elbow using an adjustable torque wrench.

 **NOTE**

- Remove any old sealing tape from the threads.
- If there is no changeable-diameter joint, install the high-pressure elbow directly to the fire cylinder.
- If there is no changeable-diameter joint and high-pressure elbow, install the extinguishant release hose to the fire cylinder.

Step 13 Install the hose connector to the ESS pipe using an adjustable torque wrench.

Figure 5-16 Installation process diagram

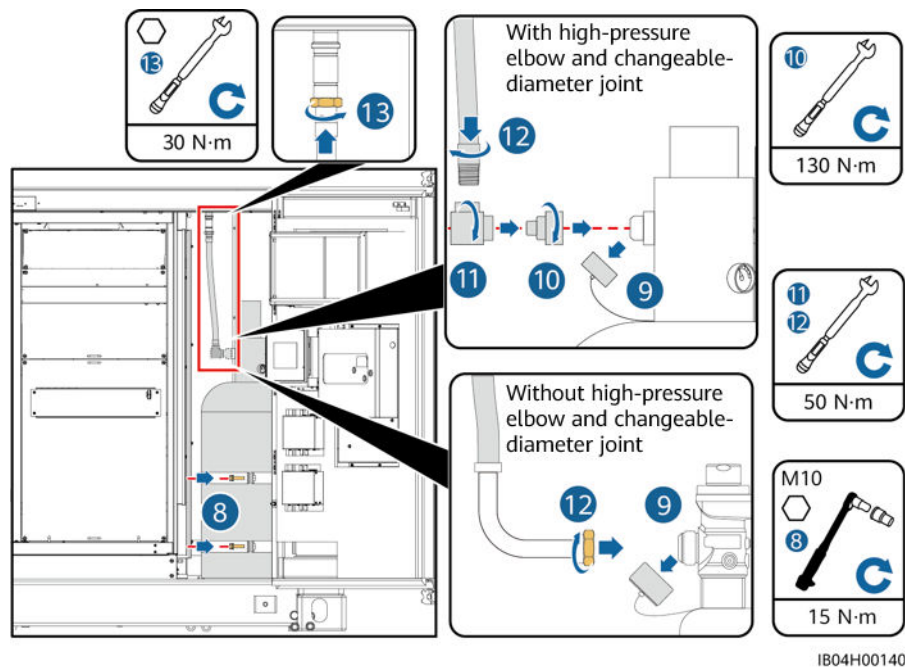

----End

5.4.3 Installing the Battery in the Extinguishant Control Panel

Prerequisites

NOTICE

- The extinguishant control panel has been configured and commissioned before delivery. Non-professional personnel are prohibited from configuring the extinguishant control panel without permission.
- Non-professional personnel are prohibited from operating the Write Enabler button.
- You are advised to power on the battery within 24 hours after unpacking. If the battery cannot be powered on in time, place it in a dry indoor environment without corrosive gases.

NOTE

- The battery is delivered with the product and can be obtained from the control unit cabin. If it needs to be replaced, purchase a battery according to the specifications in [2.6.4.4 Extinguishant Control Panel](#).
- If a battery is damaged, contact the local office.
- Determine the position of the extinguishant control panel.

Figure 5-17 Position of the extinguishant control panel

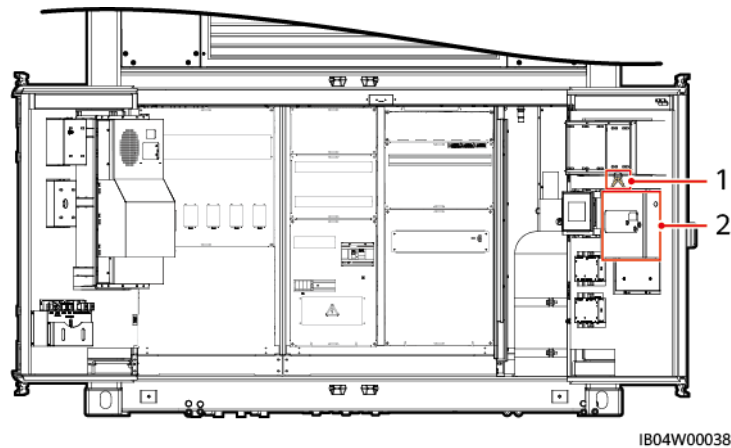

(1) Position of keys

(2) Position of the extinguishant control panel

Procedure

CAUTION

- Do not damage components in the extinguishant control panel during the installation.
- If the power supply is disconnected, restore the power supply to the extinguishant control panel as soon as possible to prevent battery failure.

-
- **Model: JB-QBL-QM210**

CAUTION

If the extinguishant control panel has been powered off for more than 24 hours, the battery switch in the extinguishant control panel must be turned off. Otherwise, the battery may be overdischarged and needs to be replaced.

-
- a. Remove the key from above the extinguishant control panel.
 - b. Open the extinguishant control panel and remove the cover for installing the battery.
 - c. Install the battery and cover in the extinguishant control panel.
 - d. Connect battery cables to the extinguishant control panel.

Figure 5-18 Installing the battery in the extinguishant control panel

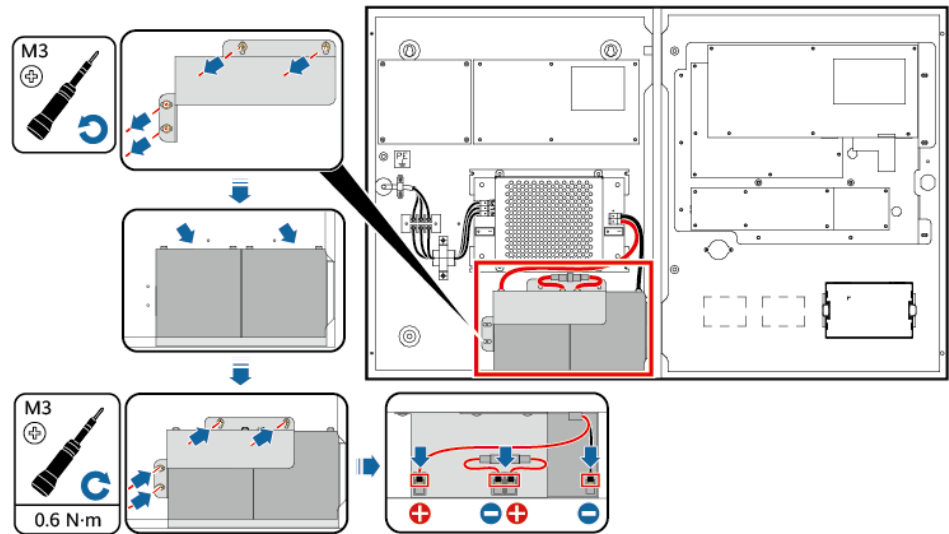

IB04110001

- e. Close the extinguishant control panel.
- f. Remove the key from the extinguishant control panel.

NOTE

Hand over the key to the responsible personnel for safekeeping.

- **Model: K11031M2**

CAUTION

If the extinguishant control panel has been powered off for more than 24 hours, cables between the extinguishant control panel and the battery must be disconnected. Otherwise, the battery may be overdischarged and needs to be replaced.

- a. Remove the key from above the extinguishant control panel and open the extinguishant control panel.
- b. Cut off the cable ties from battery cables on the main board of the extinguishant control panel.
- c. Connect battery cables to the extinguishant control panel.

Figure 5-19 Installing the battery in the extinguishant control panel

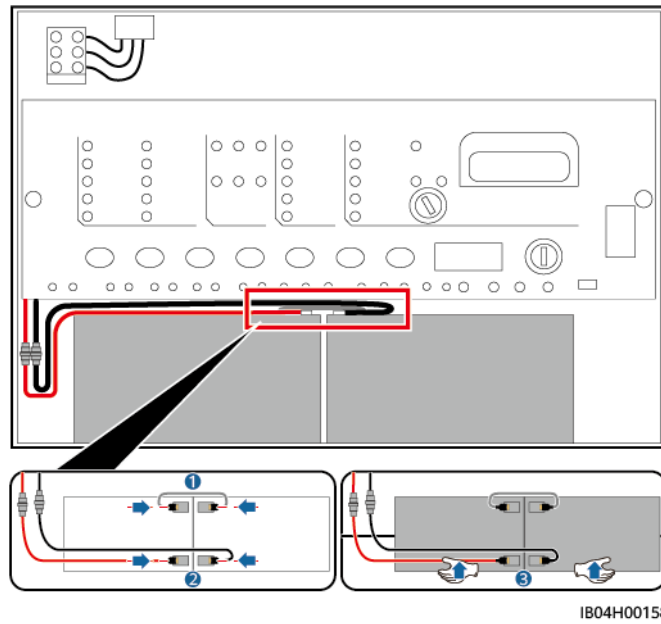

- d. Close the extinguishant control panel.
- e. Remove the key from the extinguishant control panel.

NOTE

Hand over the key to the responsible personnel for safekeeping.

6 Installing Cables

DANGER

- Do not smoke or have an open flame around batteries.
- The site must be equipped with qualified fire fighting facilities, such as fire sand and carbon dioxide fire extinguishers.
- Wear personal protective equipment and use dedicated insulated tools to avoid electric shocks or short circuits.

CAUTION

- Do not connect two or more cables to the positive or negative power port of a battery in parallel.
- Stay away from the equipment when preparing cables to prevent cable scraps from entering the equipment. Cable scraps may cause sparks and result in personal injury and equipment damage.

NOTICE

- Do not install battery packs on rainy, snowy, or foggy days. Otherwise, the battery packs may be corroded by moisture or rain.

6.1 Preparing Cables

CAUTION

Select cables in compliance with local cable standards, especially the electrical specifications and application environment. The key factors include the rated current, cable type, routing method, maximum expected line loss, rated temperature, ambient temperature, thermal resistance, acidity, sedimentation, and environmental protection requirements.

Table 6-1 Cable description

No.	Cable	Type	Conductor Cross-Sectional Area Range	Outer Diameter	Terminal	Source
1	DC power cable (connecting to the PCS, single crimp)	Single-core outdoor copper/copper-clad aluminum/aluminum alloy cable	70–185 mm ²	25–47 mm	M12 OT/DT terminal	Prepared by the customer
	DC power cable (connecting to the PCS, single crimp)	Two-core outdoor copper/copper-clad aluminum/aluminum alloy cable	95–185 mm ²	25–68 mm	M12 OT/DT terminal	Prepared by the customer
	DC power cable (connecting to the PCS, double crimp)	Single-core outdoor copper/copper-clad aluminum/aluminum alloy cable	50–185 mm ²	15–35 mm	M8 OT/DT terminal	Prepared by the customer
	DC power cable (connecting to the PCS, double crimp)	Two-core outdoor copper/copper-clad aluminum/aluminum alloy cable	70–185 mm ²	30–60 mm	M8 OT/DT terminal	Prepared by the customer
	DC power cable (connecting to the DCBOX, single crimp)	Single-core outdoor copper/copper-clad aluminum/aluminum alloy cable	185–400 mm ²	25–47 mm	M12 OT/DT terminal	Prepared by the customer
	DC power cable (connecting to the DCBOX, single crimp)	Two-core outdoor copper/copper-clad aluminum/aluminum alloy cable	240–400 mm ²	25–68 mm	M12 OT/DT terminal	Prepared by the customer
2	AC input power cable (with external grid power supply)	Four-core/Five-core outdoor copper/copper-clad aluminum/aluminum alloy cable	10–185 mm ²	16.5–72 mm	M10 OT/DT terminal	Prepared by the customer

No.	Cable	Type	Conductor Cross-Sectional Area Range	Outer Diameter	Terminal	Source
3	Single-phase AC input power cable (without external grid power supply)	Two-core/Three-core outdoor copper cable	1.5–10 mm ²	5–32 mm	Pin cord end terminal with an insertion depth of 14 mm	Prepared by the customer
4	FE communications cable	CAT 5E outdoor shielded network cable, internal resistance ≤ 1.5 ohms/10 m	-	< 9 mm	Shielded RJ45 connector	Prepared by the customer
5	Optical fiber cable	Four-core or eight-core single-mode armored cable with the transmission wavelength of 1310 nm	-	≤ 18 mm	-	Prepared by the customer

Note:

- FE/SFP communication is supported between the SACU and ESS. If the distance is greater than 100 m, use an optical fiber cable for communication through SFP ports. If the distance is less than or equal to 100 m, use an Ethernet cable for communication through FE ports.
- When the PCS model is LUNA2000-100KTL-NHH1, the length of DC power cables between the ESS and PCS shall be greater than 12 m. For other PCS models, the length of DC power cables between the ESS and PCS shall be greater than 5 m.
- The cable specifications are only recommended values. Select cables based on site requirements. The cable specifications shall be designed by the corresponding design institute.
- In the grid-forming scenario, use the double crimp.

6.2 (Optional) Installing a Socket

Scenario 1

The following table lists the applicable models.

Model	Air Conditioner Position in the Battery Cabin
LUNA2000-2.0MWH-4H1	5/11
LUNA2000-2.0MWH-2H1	1/4/7/10

Model	Air Conditioner Position in the Battery Cabin
LUNA2000-2.0MWH-HE2H1	1/4/7/10
LUNA2000-2.0MWH-HE1H1	1/3/5/7/9/11
LUNA2000-2.0MWH-1H1	1/3/5/7/9/11
LUNA2000-1.0MWH-1H1	1/5/7
LUNA2000-1.0MWH-ES1H1	1/5/7

 **NOTE**

- Cables 1733, 1735, 1734, and 1736 are preinstalled. Cables 1751, 1752, 1757, 1760, 2055, 2056, 1761, and 1762 need to be installed.
- The cables to be installed can be obtained from the position where the cables are bound, as shown in the following figure.

Figure 6-1 Status before installation

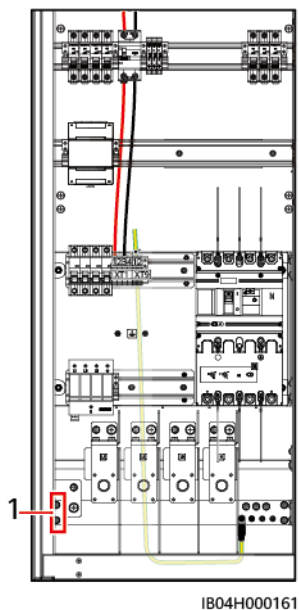

(1) Cable binding position

Step 1 Select a 110 V or 220 V socket as required.

Step 2 Connect the live wire and neutral wire.

- **Installing a 110 V socket**
 - a. Connect the live wire and neutral wire from the mains to positions 1 and 2 of the XT9 terminal block.

Figure 6-2 Connecting the live wire and neutral wire from the mains

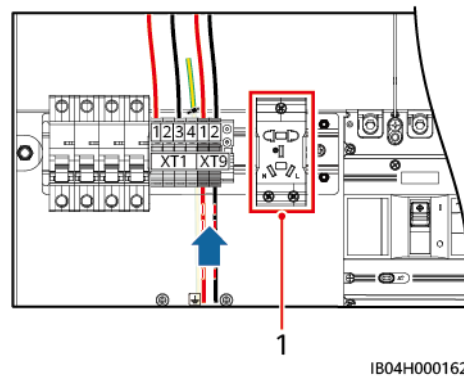

(1) Installation position of the 110 V or 220 V socket

- b. Install the 110 V switch.
- c. Connect the live wire (corresponding to cable 2056) and neutral wire (corresponding to cable 2055) from the upper end of the switch to positions 1 and 2 of the XT9 terminal block. Connect the live wire (corresponding to cable 1751) and neutral wire (corresponding to cable 1752) from the lower end of the switch to the socket.

Figure 6-3 Connecting the live wire and neutral wire

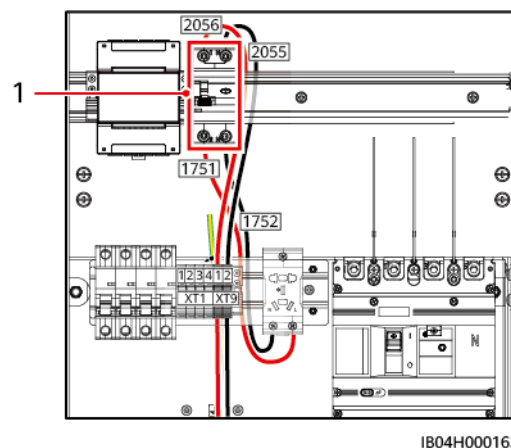

(1) Installation position of the 110 V switch

- **Installing a 220 V socket**
 - a. Connect the live wire (corresponding to cable 1757) and neutral wire (corresponding to cable 1760) from the lower end of the terminal block to the socket.

Figure 6-4 Connecting the live wire and neutral wire between the terminal block and socket

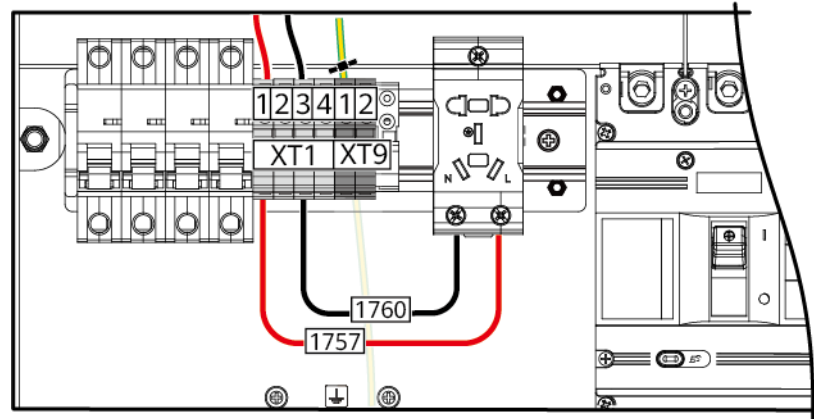

IB04H000164

Step 3 Connecting the ground cable: Determine whether the socket ground cable is routed in from the top or bottom.

NOTE

Step 3 applies to both 220 V and 110 V socket installation scenarios. The following figures use the 220 V socket as an example.

- If the ground cable is routed in from the top, as the cable (1761) has been connected to the ground, remove the other end of the cable from the rear panel and connect it to the ground point of the socket.

Figure 6-5 Routing the ground cable in from the top

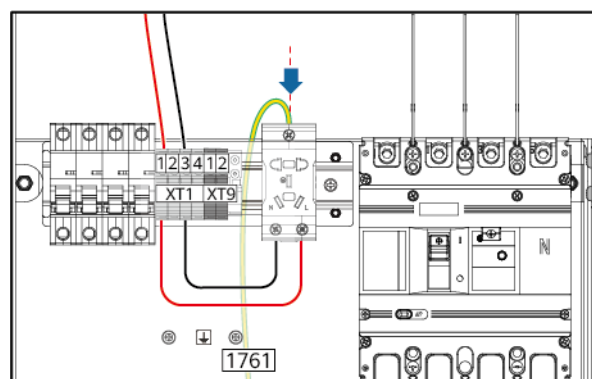

IB04H000165

- If the ground cable is routed in from the bottom, connect one end of the cable (1762) to the ground point of the socket and the other end to the reserved ground point on the rear panel.

Figure 6-6 Routing the ground cable in from the bottom

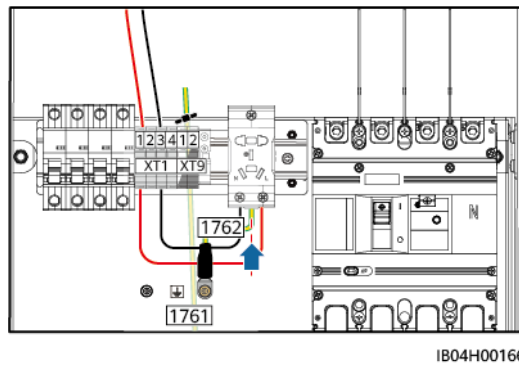

----End

Scenario 2

The following table lists the applicable models.

Model	Air Conditioner Position in the Battery Cabin
LUNA2000-2.0MWH-2H1	1/3/5/7/9/11
LUNA2000-2.0MWH-2H0	2/4/6/8/10/12
LUNA2000-2.0MWH-1H1	1/2/4/5/7/8/10/11
LUNA2000-2.0MWH-1H0	1/2/4/5/7/8/10/11

NOTE

- Cables 1755, 1758, 2066, 2065, 1761, and 1766 are preinstalled. Cables 1756, 1751, 1759, 1752, 1757, 1763, 1760, 1765, 1762, and 1764 need to be installed.
- The cables to be installed can be obtained from the position where the cables are bound, as shown in the following figure.

Figure 6-7 Status before installation

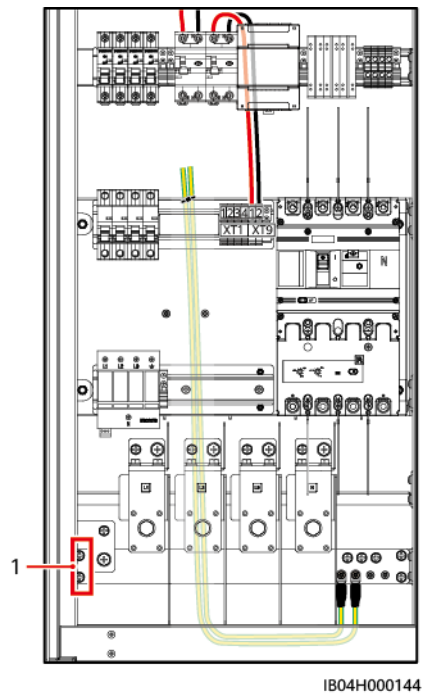

(1) Cable binding position

Step 1 Select a 110 V or 220 V socket as required.

Step 2 Connect the live wire and neutral wire.

- **Installing a 110 V socket**

- a. Connect the live wire and neutral wire from the mains to positions 1 and 2 of the XT9 terminal block.

Figure 6-8 Connecting the live wire and neutral wire from the mains

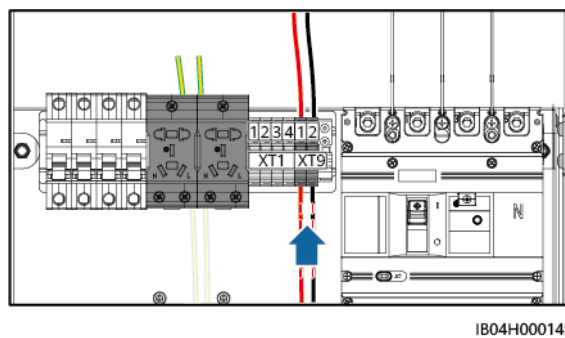

- b. Connect the live wire (corresponding to cable 1751) and neutral wire (corresponding to cable 1752) from the lower end of the switch to positions 1 and 3 of the XT1 terminal block.

Figure 6-9 Connecting the live wire and neutral wire from the lower end of the switch

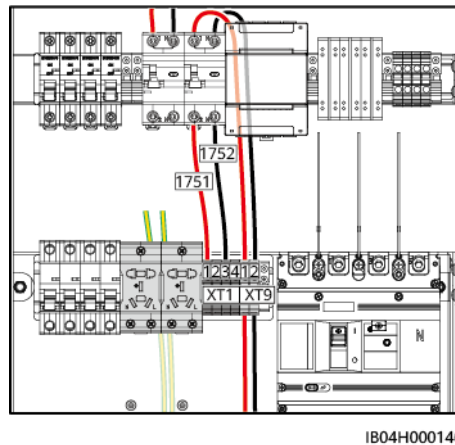

- **Installing a 220 V socket**

Connect the live wire (corresponding to cable 1756) and neutral wire (corresponding to cable 1759) from the lower end of the switch to positions 1 and 3 of the XT1 terminal block.

Figure 6-10 Connecting the live wire and neutral wire from the lower end of the switch

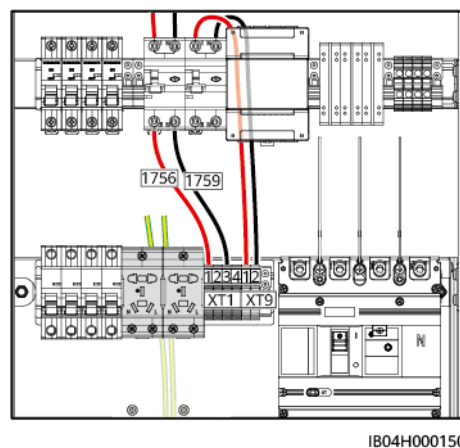

Step 3 Connect the live wires (corresponding to cables 1757 and 1763) and neutral wires (corresponding to cables 1760 and 1765) from the lower end of the terminal block to the socket.

NOTE

Steps 3 and 4 apply to both 220 V and 110 V socket installation scenarios. The following figures use the 220 V socket as an example.

Figure 6-11 Connecting the live wires and neutral wires from the lower end of the terminal block

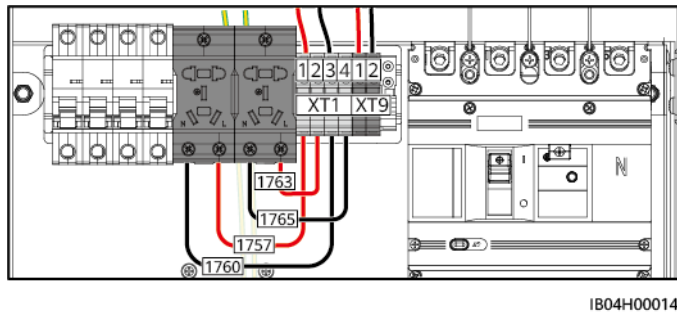

IB04H000147

Step 4 Connecting ground cables: Determine whether the socket ground cables are routed in from the top or bottom.

- If the ground cables are routed in from the top, as the cables (1761 and 1766) have been connected to the ground, remove the other end of the cables from the rear panel and connect them to the ground points of the socket.

Figure 6-12 Routing the ground cables in from the top

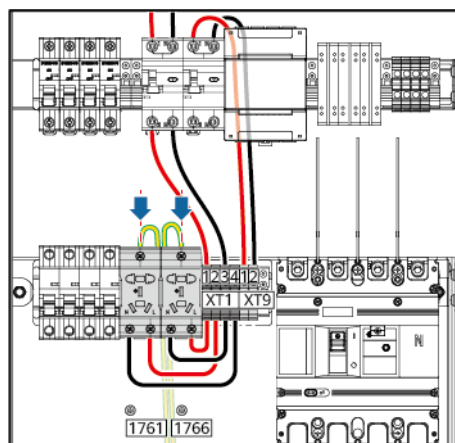

IB04H000148

- If the ground cables are routed in from the bottom, connect one end of the cables (1762 and 1764) to the ground points of the socket and the other end to the reserved ground points on the rear panel.

Figure 6-13 Routing the ground cables in from the bottom

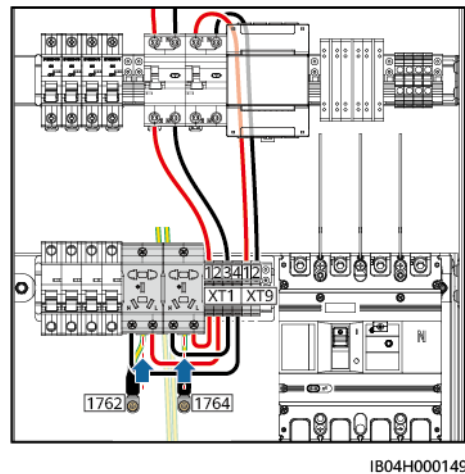

----End

6.3 Installing DC Power Cables (Single Crimp)

Prerequisites

- Before connecting cables, ensure that the ESS is not powered on.
- DC power cables have been pre-buried according to the specifications.
- The OT/DT terminals have been crimped according to the specifications. For details, see [C Crimping an OT or DT Terminal](#).

Procedure

Step 1 Remove the cover.

Figure 6-14 Removing the cover

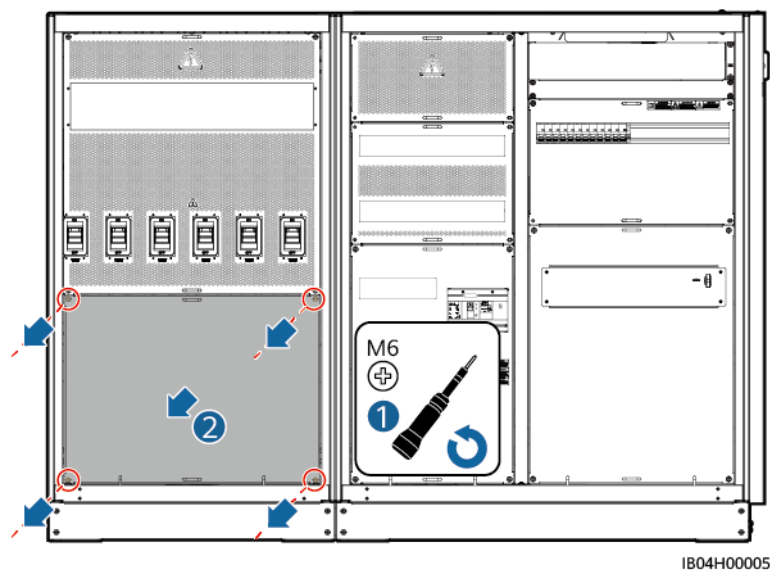

Step 2 Remove the baffle plates.

Figure 6-15 Removing the baffle plates

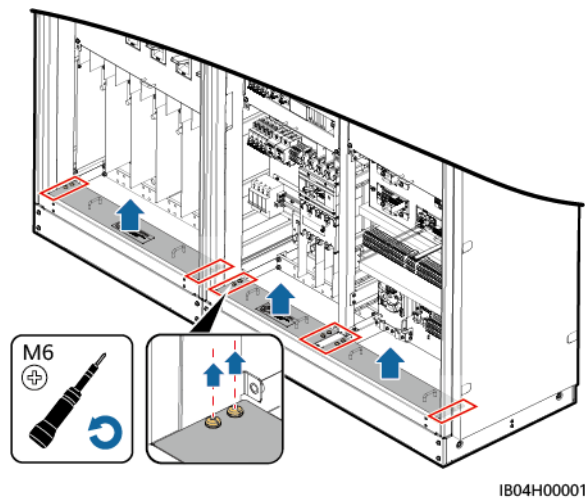

Step 3 Connect the DC power cables.

NOTICE

- The screw assembly whose model is subject to the delivery shall be tightened according to the corresponding standard torque.
- Partially tighten the nuts of the DC power cables to a torque of 5 N·m.
- Lay out the DC power cables according to the design, route the cables to the wiring positions on the corresponding switches, and label the cables.

NOTE

- Tighten the nuts using the torque socket wrench with an extension bar. The length of the extension bar is greater than 30 cm. Secure the screw assembly using an adjustable wrench.
- After connecting the DC power cables, ensure that the OT terminals are properly fitted to and aligned with the copper bar, and that the DC power cables point vertically downward.

Figure 6-16 Cable holes at the bottom

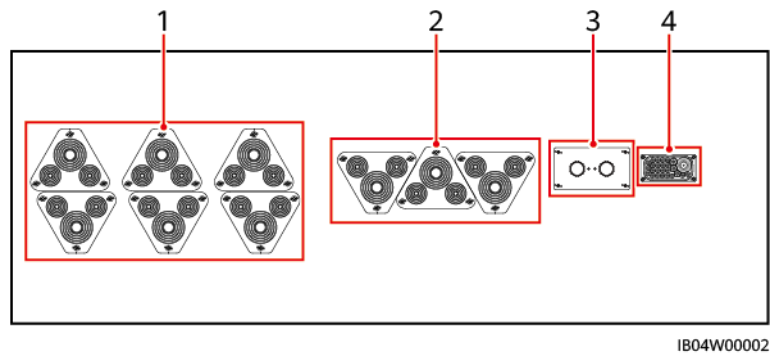

- | | |
|---|--|
| (1) DC power cable hole | (2) AC input power cable or ground cable hole |
| (3) Optical fiber cable or FE communications cable hole | (4) Single-phase AC input power cable or RS485 cable hole (reserved) |

NOTICE

- Preinstall bolts according to the recommended torque of 47 N·m.
- Verify that the torque of the installed bolts is 47 N·m using a torque socket wrench.
- Mark the nuts whose torque has been verified using a marker.
- Verify the torque promptly after connecting the negative DC power cables, and then connect the positive DC power cables.

NOTE

- When armored cables are used, it is recommended that the armored layers be connected to ground points in other cabinets.
- The number of DC power cables to be connected varies depending on the ESS model.

Figure 6-17 Connecting DC power cables (single-core cables, six circuit breakers)

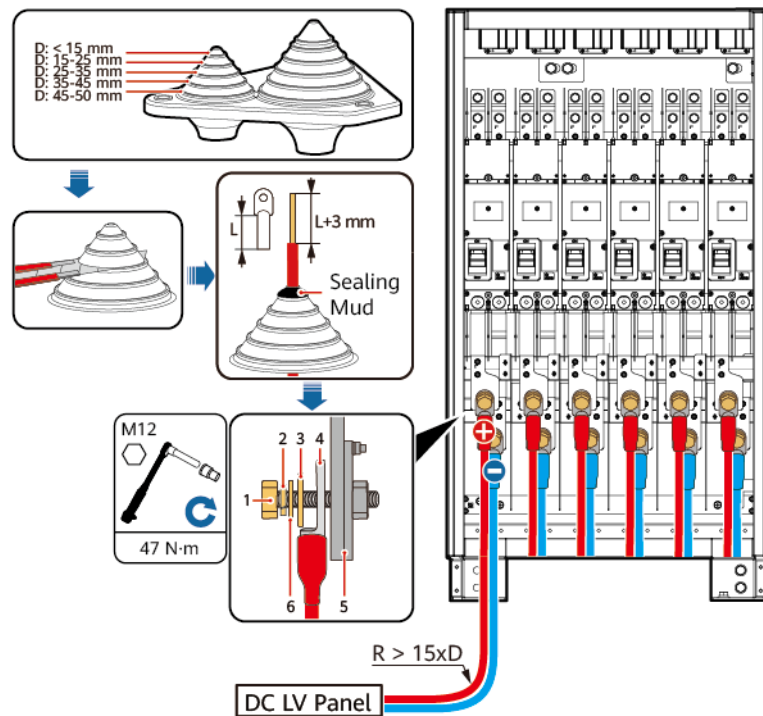

IB04I30001

Figure 6-18 Connecting DC power cables (single-core cables, three circuit breakers)

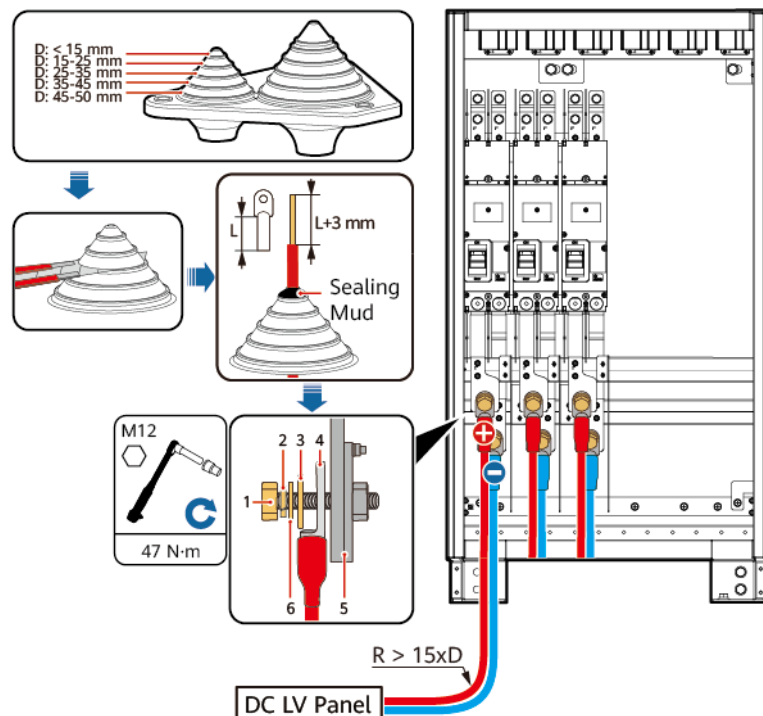

IB04I30003

- | | | |
|---------------------|-------------------|-----------------------------|
| (1) Screw assembly | (2) Spring washer | (3) Large washer (optional) |
| (4) Wiring terminal | (5) Copper bar | (6) Flat washer |

Figure 6-19 Connecting DC power cables (two-core cables, six circuit breakers)

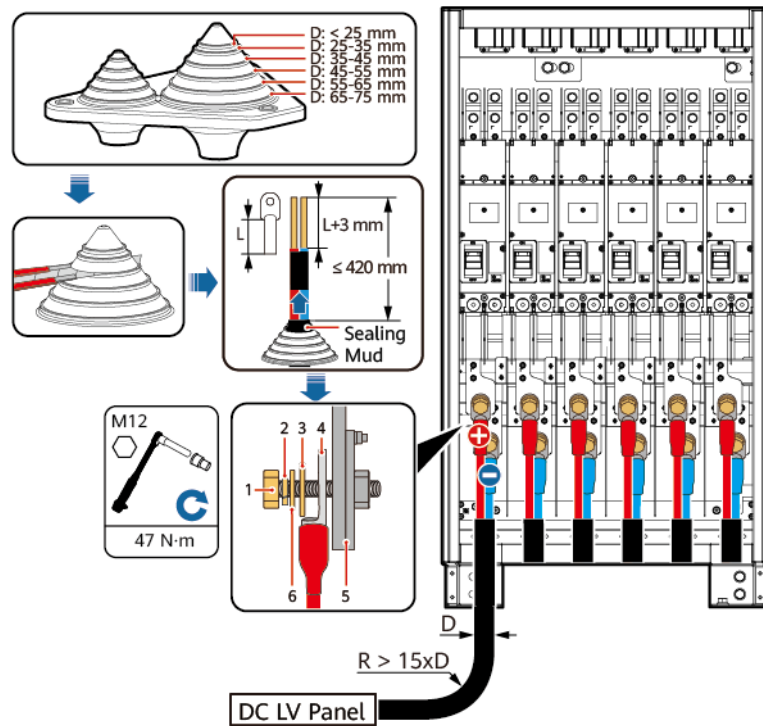

IB04130002

Figure 6-20 Connecting DC power cables (two-core cables, three circuit breakers)

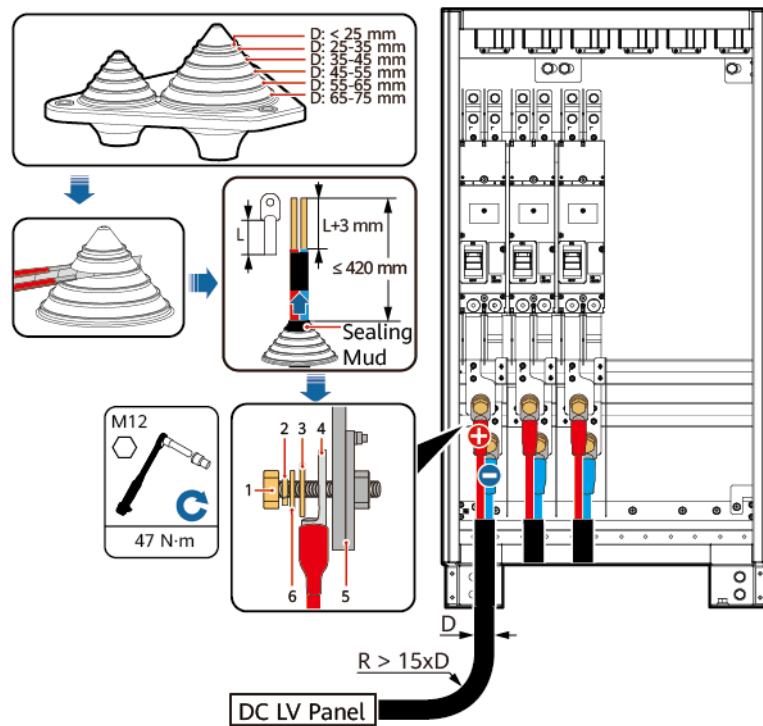

IB04130004

- | | | |
|---------------------|-------------------|-----------------------------|
| (1) Screw assembly | (2) Spring washer | (3) Large washer (optional) |
| (4) Wiring terminal | (5) Copper bar | (6) Flat washer |

Step 4 Install the removed cover.

Figure 6-21 Installing the cover

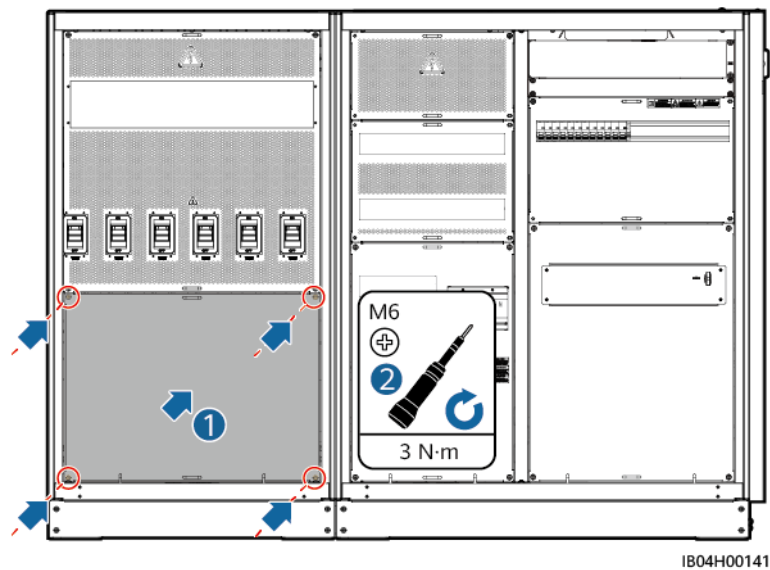

----End

6.4 Installing DC Power Cables (Double Crimp)

Prerequisites

- Before connecting cables, ensure that the ESS is not powered on.
- DC power cables have been pre-buried according to the specifications.
- The OT/DT terminals have been crimped according to the specifications. For details, see [C Crimping an OT or DT Terminal](#).

Procedure

Step 1 Remove the cover.

Figure 6-22 Removing the cover

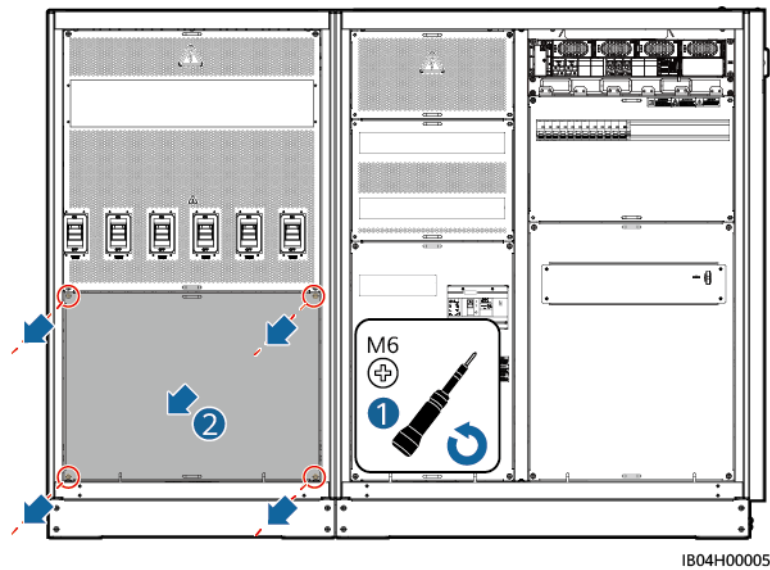

Step 2 Remove the baffle plates.

Figure 6-23 Removing the baffle plates

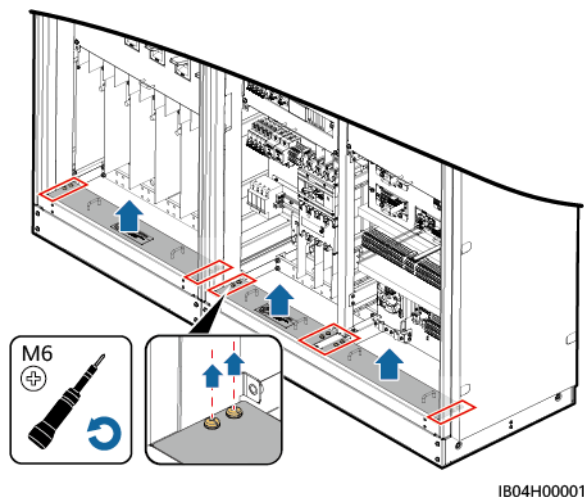

Step 3 Connect the DC power cables.

NOTICE

- The screw assembly whose model is subject to the delivery shall be tightened according to the corresponding standard torque.
- Partially tighten the nuts of the DC power cables to a torque of 5 N·m.
- Lay out the DC power cables according to the design, route the cables to the wiring positions on the corresponding switches, and label the cables.

 NOTE

- Tighten the nuts using the torque socket wrench with an extension bar. The length of the extension bar is greater than 30 cm. Secure the screw assembly using an adjustable wrench.
- After connecting the DC power cables, ensure that the OT terminals are properly fitted to and aligned with the copper bar, and that the DC power cables point vertically downward.

Figure 6-24 Cable holes at the bottom

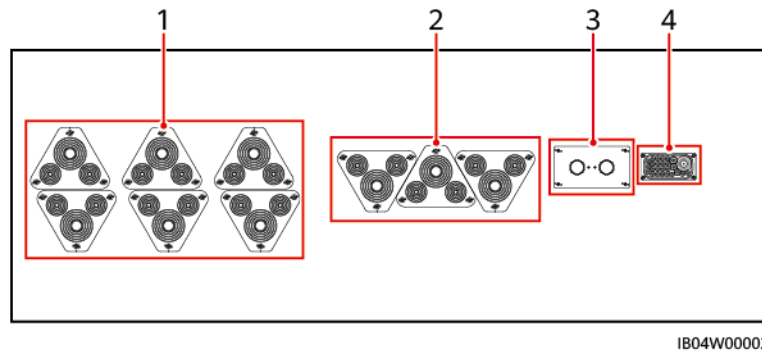

(1) DC power cable hole

(2) AC input power cable or ground cable hole

(3) Optical fiber cable or FE communications
cable hole

(4) Single-phase AC input power cable or
RS485 cable hole (reserved)

NOTICE

- Preinstall bolts according to the recommended torque of 13 N·m.
- Verify that the torque of the installed bolts is 13 N·m using a torque socket wrench.
- Mark the nuts whose torque has been verified using a marker.
- Verify the torque promptly after connecting the negative DC power cables, and then connect the positive DC power cables.

 NOTE

When armored cables are used, it is recommended that the armored layers be connected to ground points in other cabinets.

Figure 6-25 Connecting DC power cables (single-core cables, six circuit breakers)

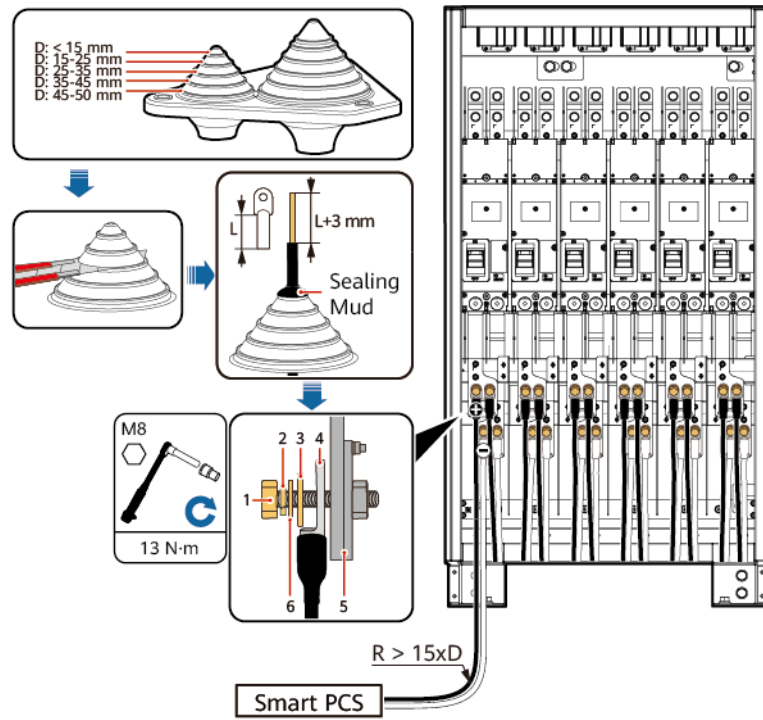

IB04130001

- | | | |
|---------------------|-------------------|-----------------------------|
| (1) Screw assembly | (2) Spring washer | (3) Large washer (optional) |
| (4) Wiring terminal | (5) Copper bar | (6) Flat washer |

Figure 6-26 Connecting DC power cables (single-core cables, three circuit breakers)

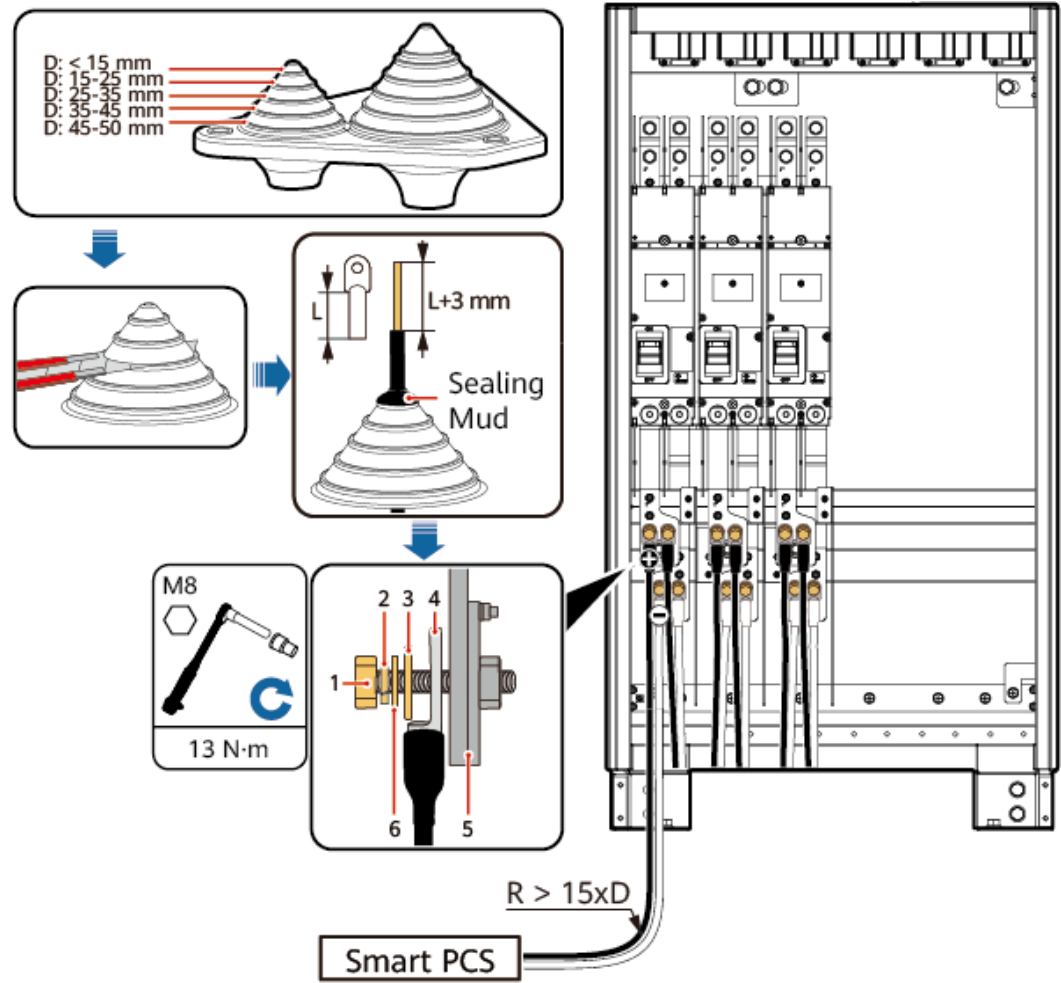

IB04I30001

- | | | |
|---------------------|-------------------|-----------------------------|
| (1) Screw assembly | (2) Spring washer | (3) Large washer (optional) |
| (4) Wiring terminal | (5) Copper bar | (6) Flat washer |

Figure 6-27 Connecting DC power cables (two-core cables, six circuit breakers)

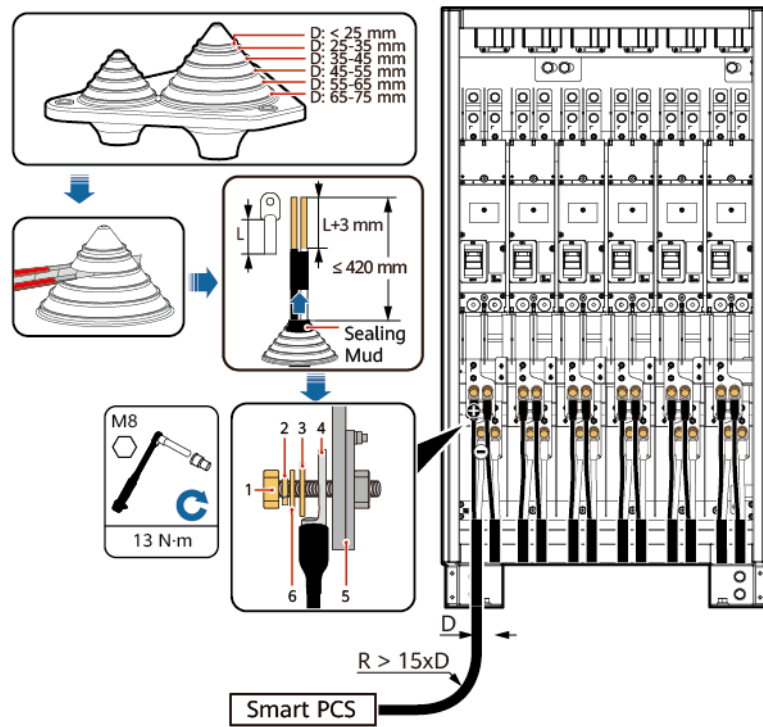

IB04I30002

- | | | |
|---------------------|-------------------|-----------------------------|
| (1) Screw assembly | (2) Spring washer | (3) Large washer (optional) |
| (4) Wiring terminal | (5) Copper bar | (6) Flat washer |

Figure 6-28 Connecting DC power cables (two-core cables, three circuit breakers)

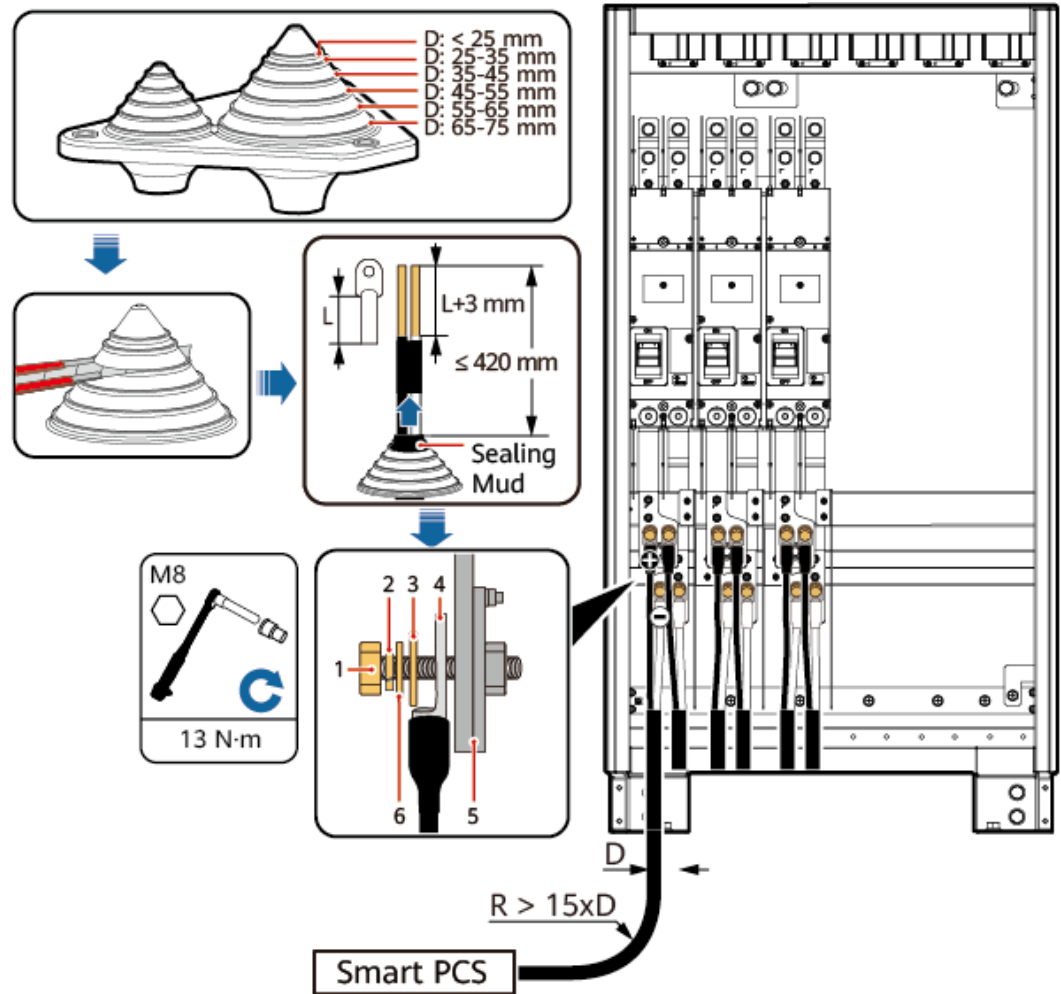

IB04I30002

- | | | |
|---------------------|-------------------|-----------------------------|
| (1) Screw assembly | (2) Spring washer | (3) Large washer (optional) |
| (4) Wiring terminal | (5) Copper bar | (6) Flat washer |

Step 4 Install the removed cover.

Figure 6-29 Installing the cover

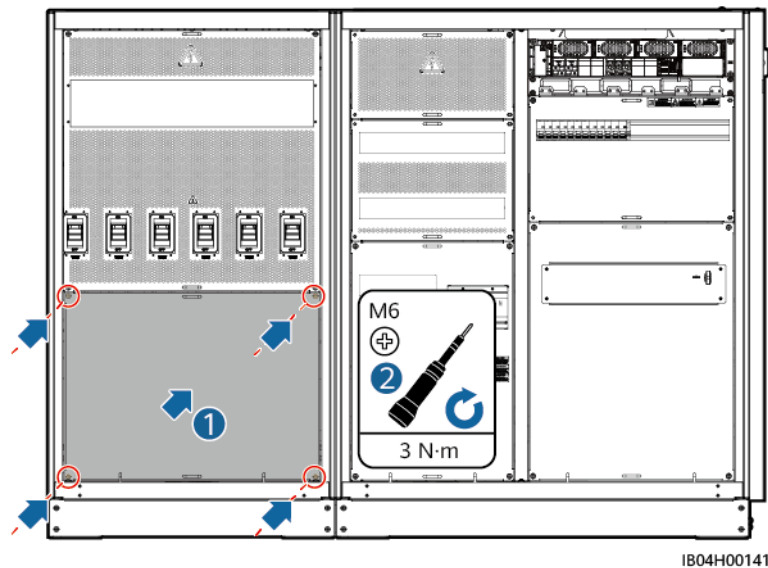

----End

6.5 Installing an AC Input Power Cable (With External Grid Power Supply)

Prerequisites

- Before connecting cables, ensure that the ESS is not powered on.
- AC input power cables have been pre-buried according to the specifications.
- The OT/DT terminals of the AC input power cables have been crimped according to the specifications. For details, see [C Crimping an OT or DT Terminal](#).

Procedure

Step 1 Remove the cover.

Figure 6-30 Removing the cover

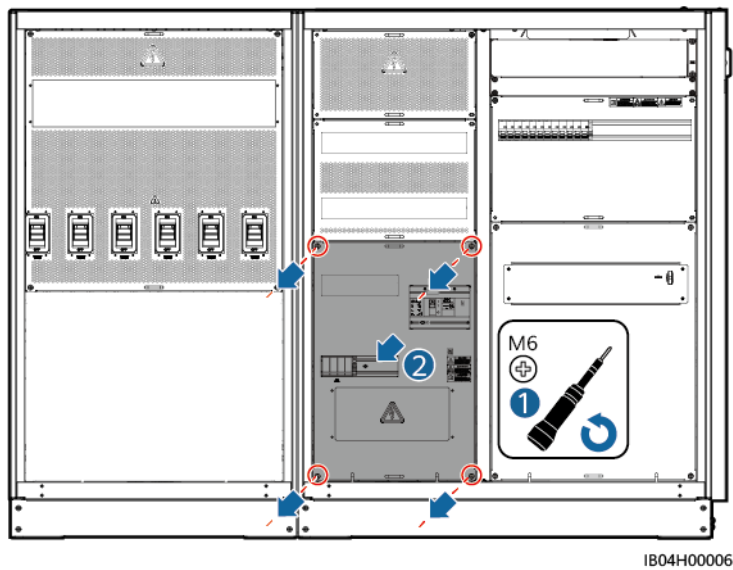

Step 2 Remove the baffle plates.

Figure 6-31 Removing the baffle plates

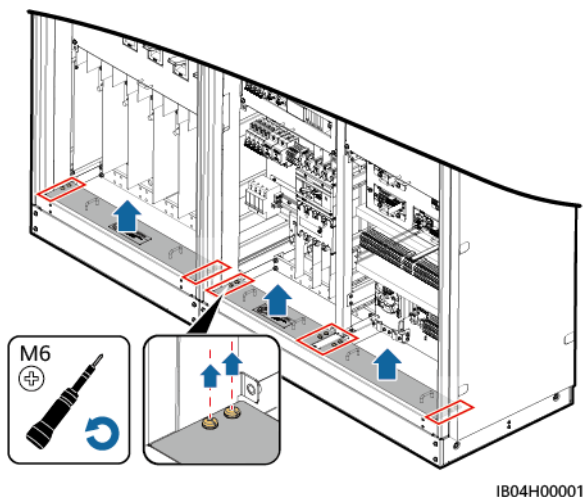

Step 3 Connect AC input power cables.

CAUTION

When connecting AC input power cables, ensure that the cables are not damaged or disconnected. Ensure that the neutral wire is securely connected. Otherwise, AC power devices in the system may be damaged.

Figure 6-33 Connecting the four-core AC input power cable (excluding the ground wire and including the neutral wire)

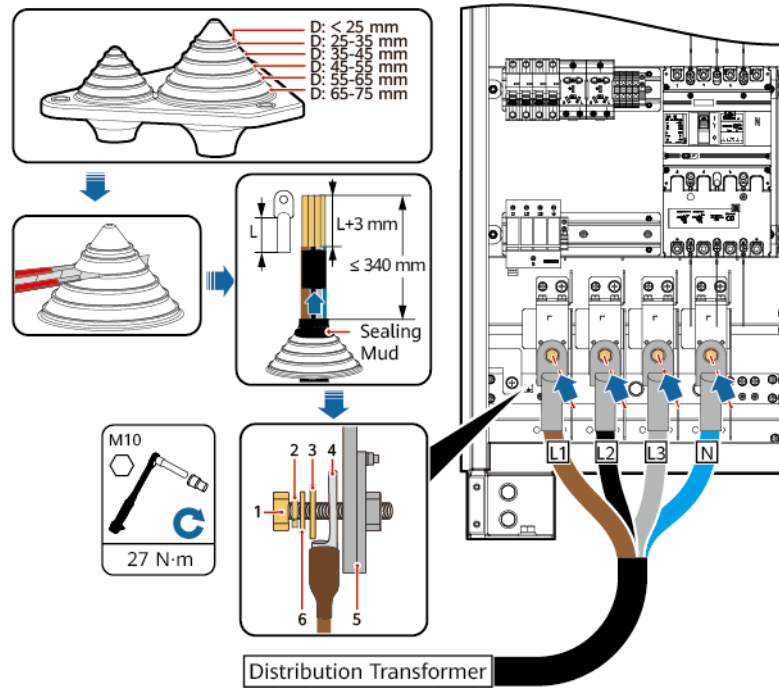

IB04I20002

- | | | |
|---------------------|-------------------|-----------------------------|
| (1) Screw assembly | (2) Spring washer | (3) Large washer (optional) |
| (4) Wiring terminal | (5) Copper bar | (6) Flat washer |

Figure 6-34 Connecting the five-core AC input power cable (including the ground wire and the neutral wire)

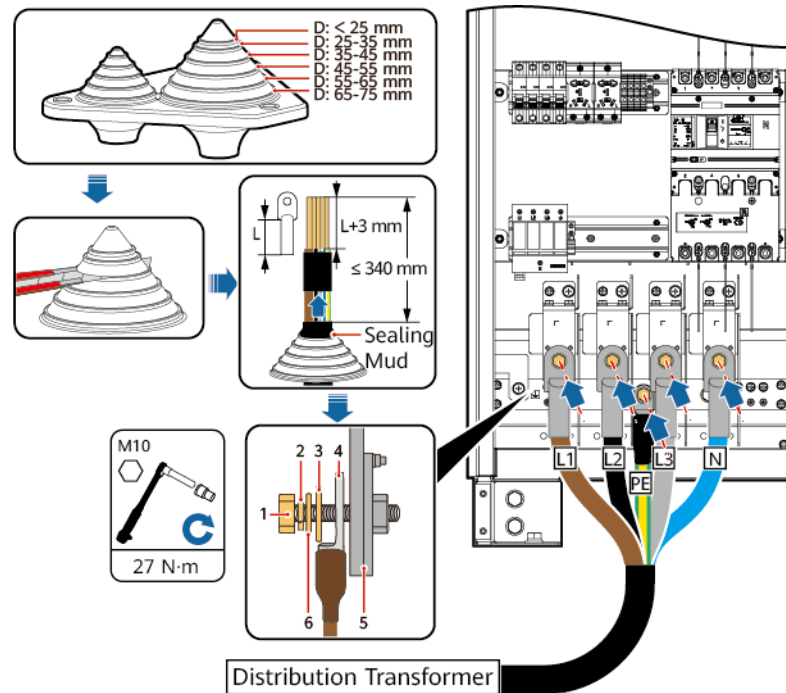

IB04I20001

- | | | |
|---------------------|-------------------|-----------------------------|
| (1) Screw assembly | (2) Spring washer | (3) Large washer (optional) |
| (4) Wiring terminal | (5) Copper bar | (6) Flat washer |

Step 4 Install the removed cover.

Figure 6-35 Installing the cover

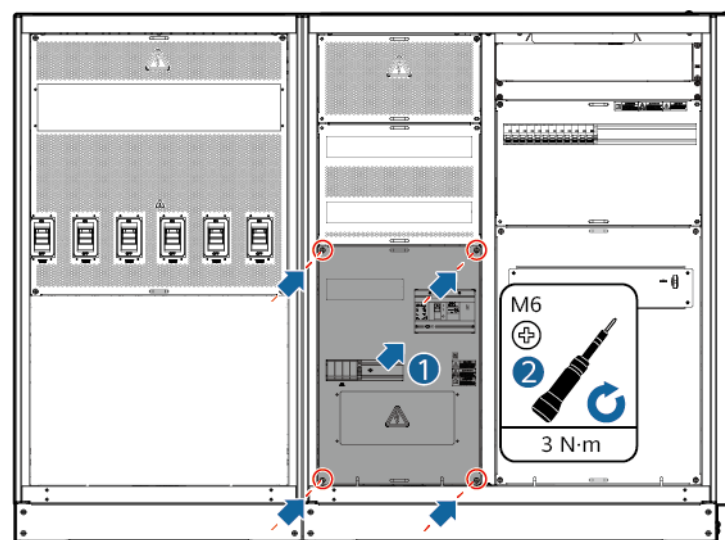

IB04H00142

----End

6.6 (Optional) Installing Single-Phase AC Input Power Cables

NOTE

- The figures are for reference only. The actual situation may vary.
- If a UPS (provided by the customer) or other reliable backup power supplies (provided by the customer) is used to supply power, perform the following steps to change the connection mode of the single-phase AC input power cables.
- Recommended single-phase AC switch (5FCB, provided by the customer): 220/230 V AC; 10 A/2P.

Scenario 1: The UPS Obtains Power from an External Power Source (Not from the ESS)

- Step 1** Remove the short-circuiting bar from 1-2 and insert it to 2-3 on the XU terminal block.
- Step 2** Remove the short-circuiting bar from 6-7 and insert it to 7-8 on the XU terminal block.
- Step 3** Connect the armored cable to the ground point on the rear panel of the control unit cabin.
- Step 4** Connect the PE cable (provided by the customer) to the ground bar of the control unit cabin, and connect the L and N wires (provided by the customer) to switch 5FCB2.

Figure 6-36 Wiring diagram

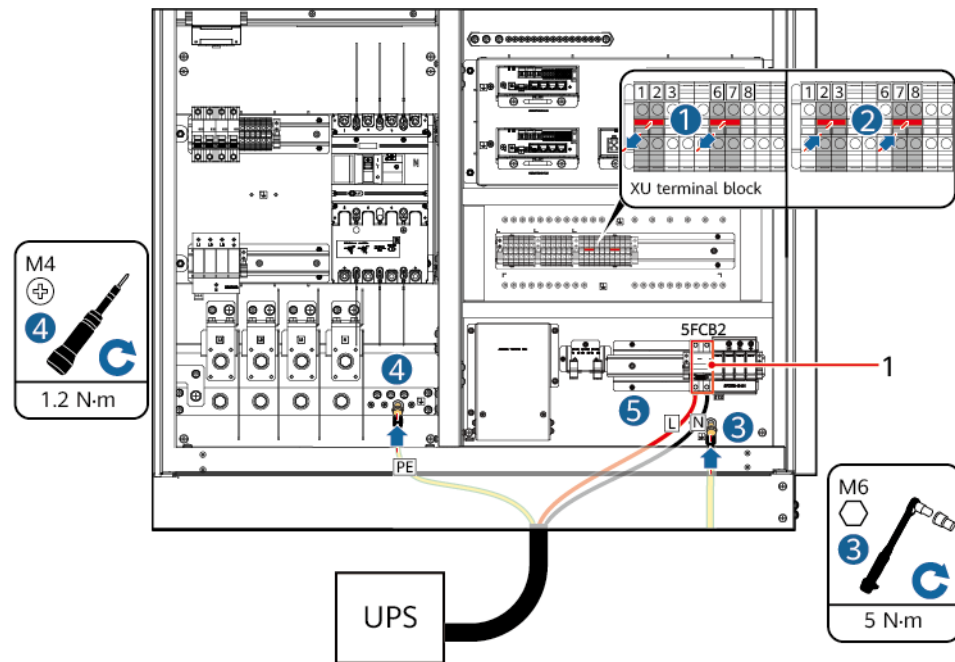

IB04H00159

(1) Switch 5FCB2, connected to (2) Binding positions of live wire 1775 and neutral wire 1777

(3) Switch 5FCB, connected to the UPS input

----End

Scenario 2: The UPS Obtains Power from the ESS

- Step 1** Remove the short-circuiting bar from 1-2 and insert it to 2-3 on the XU terminal block.
- Step 2** Remove the short-circuiting bar from 6-7 and insert it to 7-8 on the XU terminal block.
- Step 3** Connect the two armored cables to the ground points on the rear panel of the control unit cabin.
- Step 4** UPS output: Connect the PE cable (provided by the customer) to the ground bar of the control unit cabin, and connect the L and N wires (provided by the customer) to switch 5FCB2.
- Step 5** Install a UPS switch 5FCB (provided by the customer).
- Step 6** Connect the live wire 1775 and neutral wire 1777 (obtained from position 3 in the figure).
- Step 7** UPS input: Connect the PE cable (provided by the customer) to the ground bar of the control unit cabin, and connect the L and N wires (provided by the customer) to switch 5FCB.

Figure 6-37 Wiring diagram

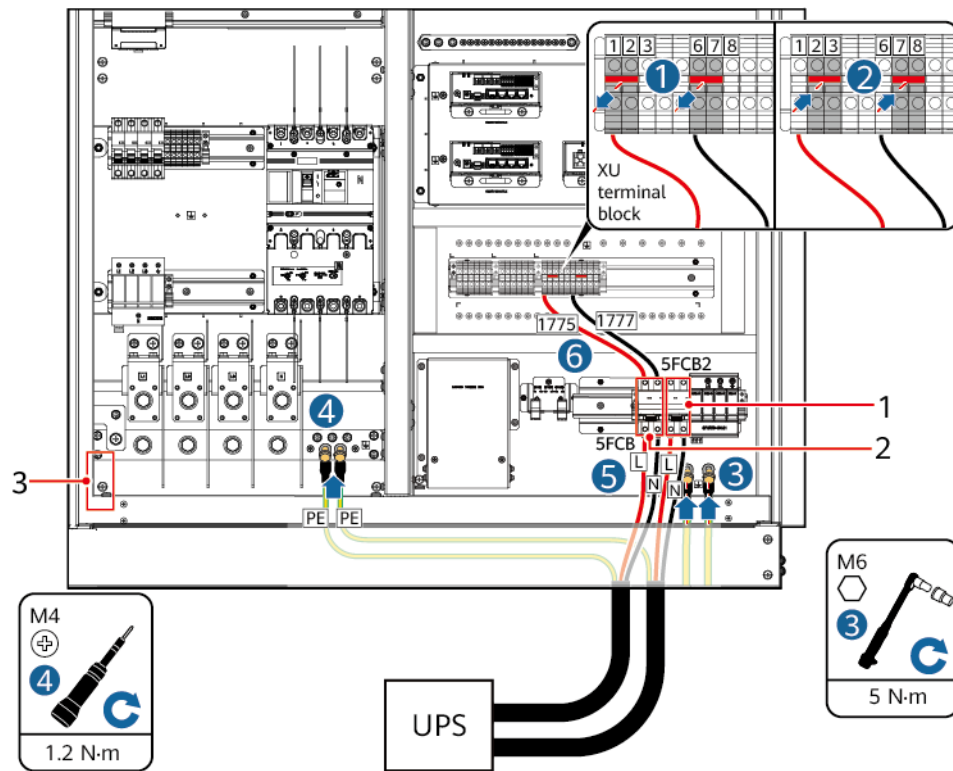

IB04H00159

----End

6.7 Installing Signal Cables

6.7.1 Installing FE Communications Cables

Step 1 Remove the cover.

Figure 6-38 Removing the cover

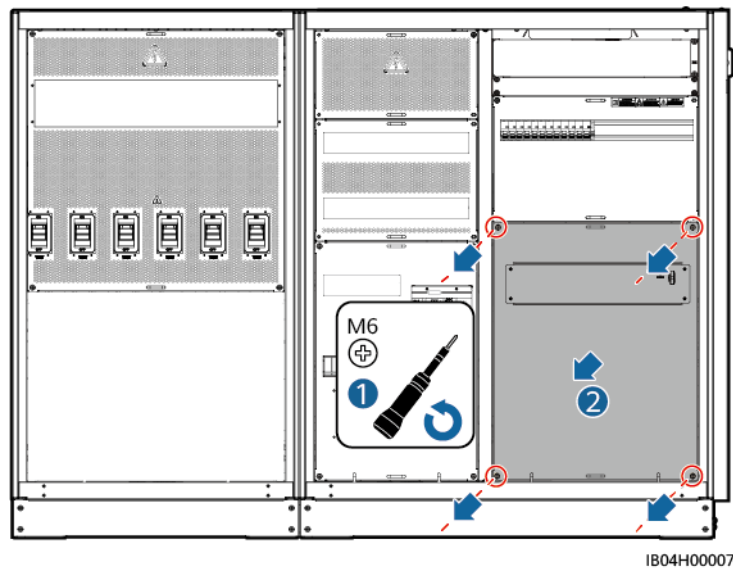

Step 2 Remove the baffle plates.

Figure 6-39 Removing the baffle plates

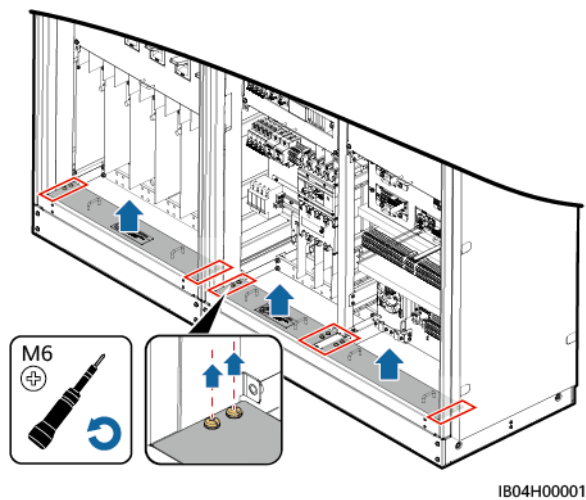

Step 3 Connect the FE communications cables to the **WAN** ports on the CMU.

Figure 6-40 Cable holes at the bottom

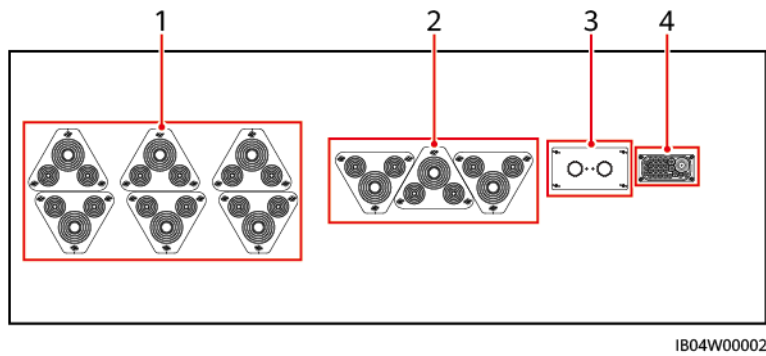

- (1) DC power cable hole
- (2) AC input power cable or ground cable hole
- (3) Optical fiber cable or network cable hole
- (4) UPS or RS485 cable hole (reserved)

Figure 6-41 Connecting FE communications cables

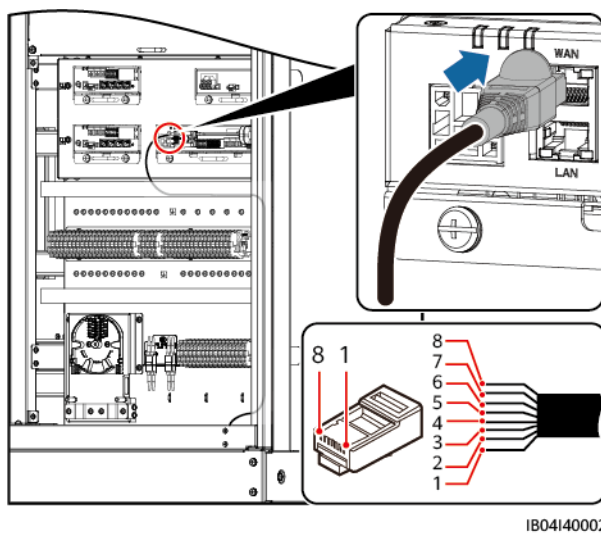

- (1) White-and-orange
- (2) Orange
- (3) White-and-green
- (4) Blue
- (5) White-and-blue
- (6) Green
- (7) White-and-brown
- (8) Brown

Step 4 Bind the cables.

Step 5 Install the removed cover.

Figure 6-42 Installing the cover

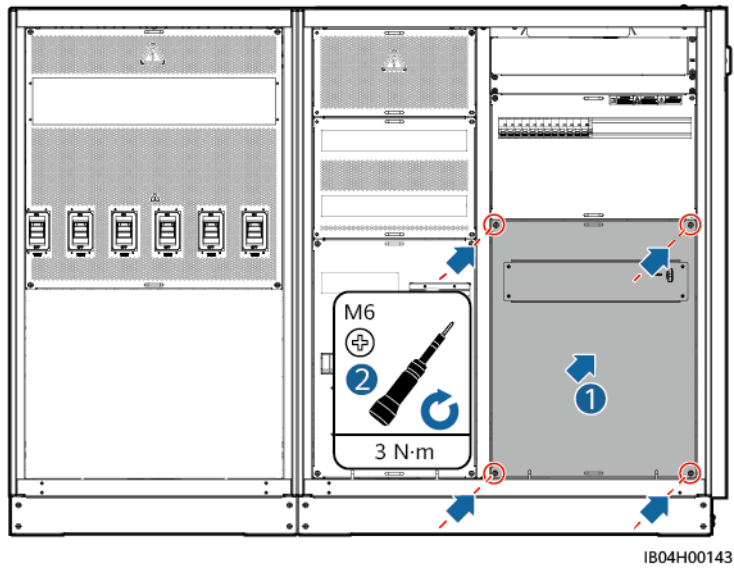

----End

6.7.2 Installing Optical Fiber Cables

NOTICE

Only professionals are allowed to connect optical fiber cables and splice fibers.

Figure 6-43 Access terminal box (ATB) interior

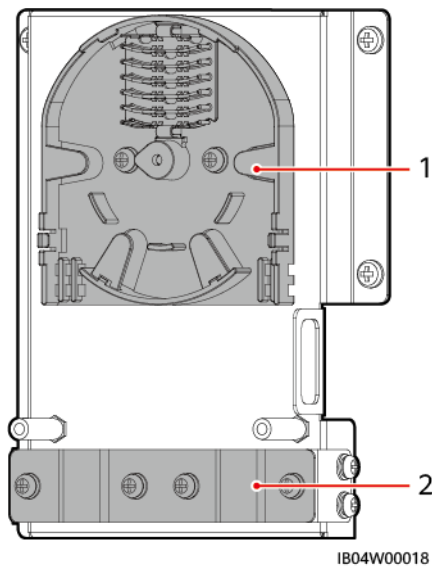

(1) Fiber spool

(2) Cable clip

Step 1 Remove the cover.

Figure 6-44 Removing the cover

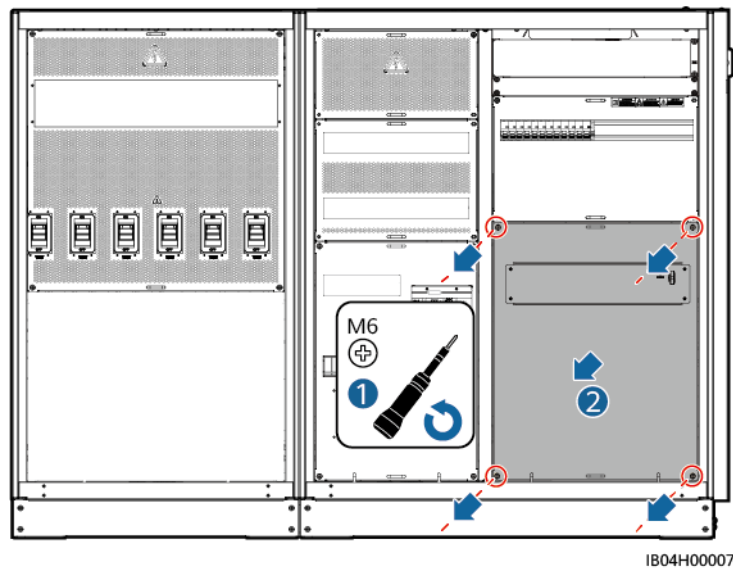

Step 2 Remove the baffle plates.

Figure 6-45 Removing the baffle plates

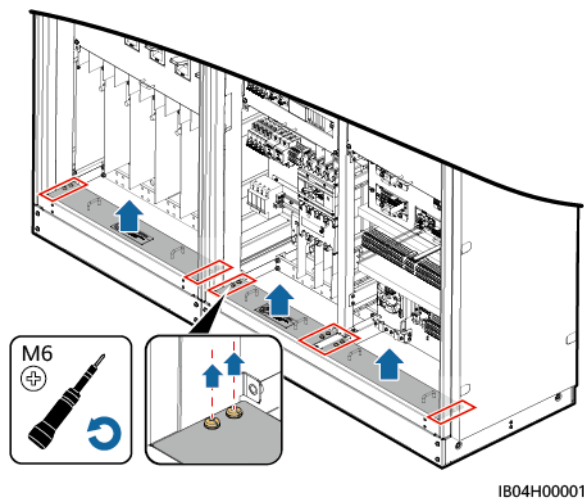

Step 3 Remove the external mechanical parts from the ATB.

NOTE

Only some models have external mechanical parts of the ATB.

Figure 6-46 Removing the external mechanical parts

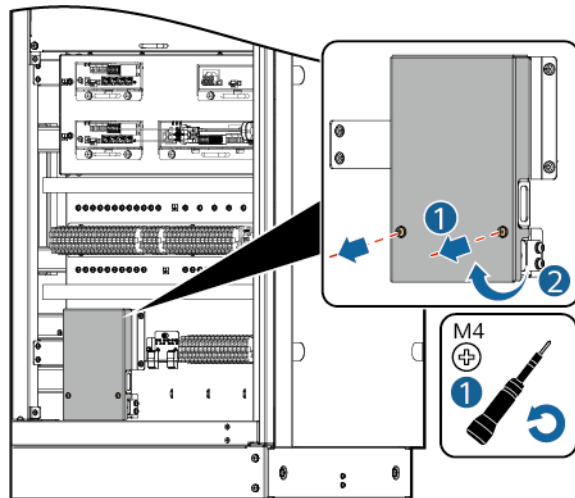

IB04H00003

Step 4 Remove the optical fiber cable fastener.

Figure 6-47 Removing the fastener

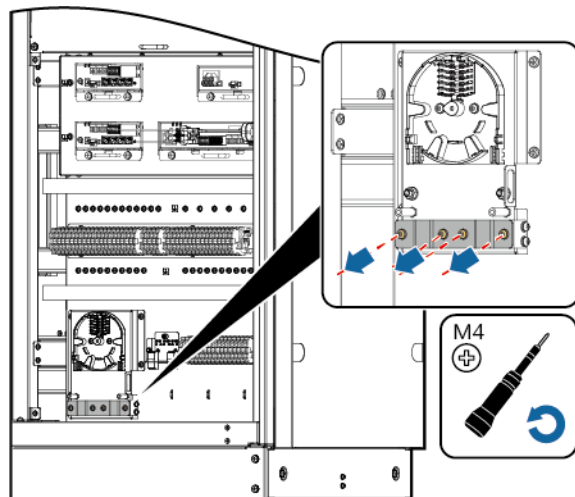

IB04H00004

Step 5 Connect one end of the optical jumper to the fiber adapter.

Step 6 Route the other end of the optical jumper through the cable hole on the side of the ATB, and connect the cable to the ATB.

Step 7 Connect the peripheral optical fiber cable to the ATB, splice the optical fiber cable and the optical jumper, and then wind the spliced cable around the fiber spool on the ATB.

Step 8 Install an optical module on the CMU panel, connect one end of the optical jumper to the optical module, and connect the other end to the fiber adapter.

NOTICE

Only professionals are allowed to splice fibers.

Figure 6-48 Cable holes at the bottom

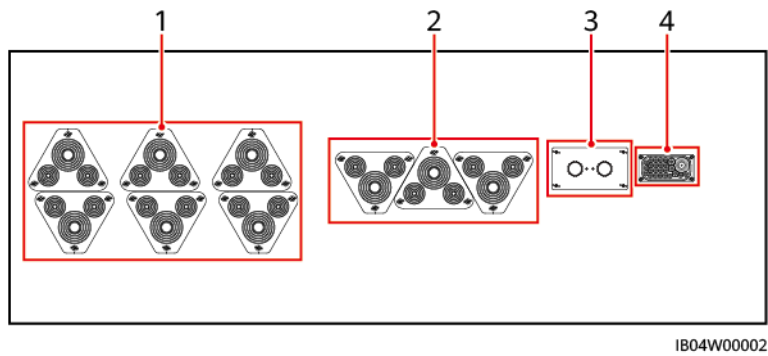

- (1) DC power cable hole
- (2) AC input power cable or ground cable hole
- (3) Optical fiber cable or FE communications cable hole
- (4) UPS or RS485 cable hole (reserved)

Figure 6-49 Connecting optical fiber cables

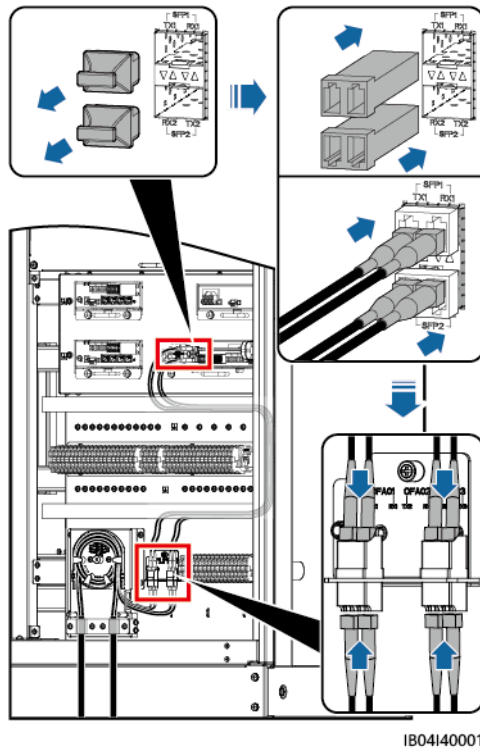

Step 9 Check that the cables are connected correctly and securely. Then reinstall the optical fiber cable fastener and external mechanical parts.

Step 10 Install the removed cover.

Figure 6-50 Installing the cover

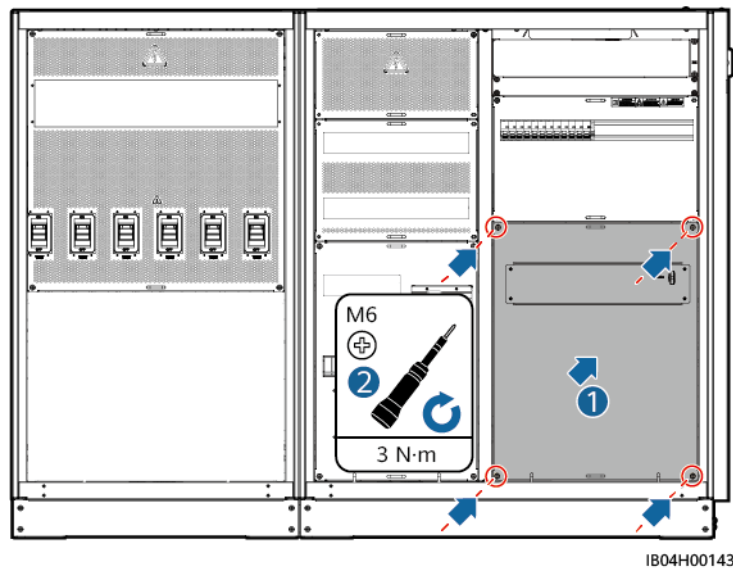

----End

6.8 Sealing the Cable Holes

After the cables are installed, seal the cable holes using the sealing mud delivered with the equipment.

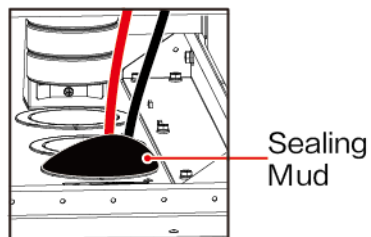

IB03W00018

7 Check Before Power-On

Item	No.	Check Item	Acceptance Criteria
General inspection	1	Equipment appearance	<ul style="list-style-type: none"> The equipment is intact and free from rust or paint flake-off. If paint flakes off, repaint the equipment. The labels on the equipment are clear. Damaged labels must be replaced.
	2	Cable appearance	<ul style="list-style-type: none"> Cable sheathings are properly wrapped and not damaged. Cable hoses are intact.
	3	Cable connections	<ul style="list-style-type: none"> Cables are connected in the designed positions. Terminals are prepared as required and securely connected. Labels on both ends of each cable are clear and specific, and attached in the same direction.
	4	Cable layout	<ul style="list-style-type: none"> Electrical and ELV cables are routed separately. Cables are neat and tidy. Cable tie joints are evenly cut without burrs. Cables are placed properly and reserve some slack at bending points to avoid stress. Cables are routed neatly without twists or crossovers in the cabinet.
	5	Switch	<ul style="list-style-type: none"> The DC LV Panel switch is set to OFF. The battery rack switch is set to OFF.

Item	No.	Check Item	Acceptance Criteria
ESS	1	Installation	<ul style="list-style-type: none"> The installation meets the design requirements. The ESS is level, and each door can be opened properly.
	2	Grounding	Each ESS has at least two ground points and is grounded securely. The resistance of a bond shall be less than or equal to 0.1 ohms.
	3	Accessory	The number and positions of external accessories installed meet design requirements.
	4	Label	All labels are correct, clear, and complete.
	5	Cleanness	The ESS is clean and tidy inside, without any unnecessary cables, cable ends, terminals, or tools. No garbage is found outside the equipment.
Battery cabin	1	Circuit breaker	The MCCBs are set to OFF.
	2	Copper bar	The copper bar is not deformed, and no foreign objects are placed on the copper bar.
	3	Fuse	There is no indication for broken fuses.
	4	Cable	The bolts for installing the cables are tightened and the cables are not loose.
	5	Cable hole sealing	Cable holes have been sealed.
	6	Component	All components are intact.
	7	Foreign object	Remove all foreign objects from the battery cabin, such as tools and remaining installation materials.
Control unit cabin	1	SPD	The SPD indicator is green.
	2	AC meter	The buttons of the AC meter function properly and the screen is free of cracks.
	3	Cable	The bolts for installing the cables are tightened and the cables are not loose.
	4	Foreign object	There are no foreign objects in the control unit cabin, such as packing materials.
	5	Component (such as CMU, adapter, extinguishant control panel)	All components are intact.
	6	Fire cylinder	The pressure of fire cylinder is normal.

8 Powering On the System

8.1 Installing the PSU

Prerequisites

 **WARNING**

- Do not put your hands into the PSU slot to avoid electric shock.
 - When the PSU is running, a high temperature is generated around the air outlet at the rear. Do not touch the PSU or place cables or other objects on it.
-

 **CAUTION**

Power on the PSU within 24 hours after unpacking. Otherwise, place it in a dry indoor environment without corrosive gas.

 **NOTE**

- The subracks vary with the ESS models. The figure uses one type of subrack as an example.
- If the PSU is damaged, contact the local office.
 - Determine the PSU installation position.

Figure 8-1 PSU installation position

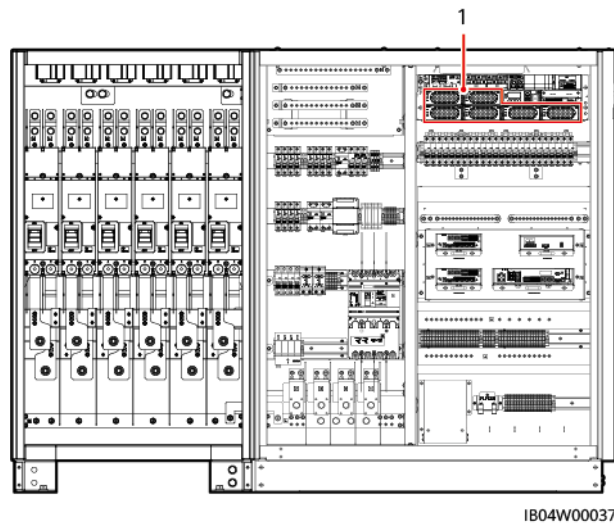

Procedure

- Step 1** Push the locking latch leftward.
- Step 2** Pull out the handle.
- Step 3** Gently push the PSU into its slot along the guide rails.
- Step 4** Push the handle upward.
- Step 5** Push the locking latch rightward to lock the handle.

Figure 8-2 Installing the PSU

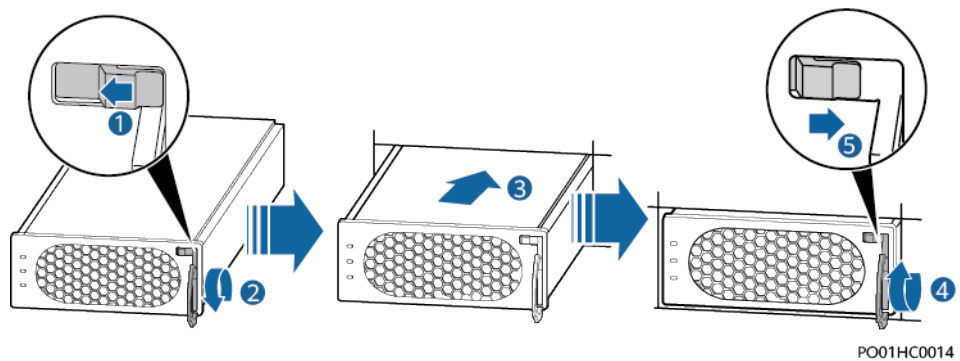

----End

8.2 Installing the Solenoid Valve

Context

⚠ CAUTION

- If a solenoid valve is configured with a reset device, ensure that the solenoid valve is not activated before installing it on the fire cylinder. For details, see "FAQ".
- Before installing the solenoid valve, ensure that the fire suppression system has been tested and passed the acceptance inspection (Auxiliary power-on is required for the test and acceptance of the fire suppression system.).

📖 NOTE

- The appearance of the solenoid valve is for reference only, and that of the actual product may vary.
- The model of the solenoid valve may vary. For details about the applicable installation procedure, see the model of the fire cylinder.

Procedure

⚠ WARNING

For non-emergency manual operations, do not remove the safety pull ring.

- **Fire cylinder model: GQQ40/2.5**

Step 1 Take out the solenoid valve from the control unit cabin and remove the electric control plug from the solenoid valve.

1. Use a small flat-head screwdriver to remove the screws.
2. Remove the electric control plug from the solenoid valve.

Step 2 Reset the solenoid valve.

If the solenoid valve is activated, perform the following steps to reset the solenoid valve.

📖 NOTE

- The solenoid valve is activated if its ejector pin protrudes by 5.5 mm.
 - The solenoid valve is inactivated if its ejector pin protrudes by 8.8 mm.
1. Insert the reset device into the solenoid valve to reset the ejector pin.
 2. After resetting, remove the solenoid valve reset device.

Step 3 Tighten the solenoid valve clockwise to the top of the fire cylinder.

Step 4 Install the electric control plug.

1. Insert the electric control plug into the solenoid valve.
2. Use a screwdriver to tighten the screws.

Step 5 Remove the safety pin.

1. Cut off the safety pin rope.
2. Remove the safety pin.

Figure 8-3 Installing the solenoid valve

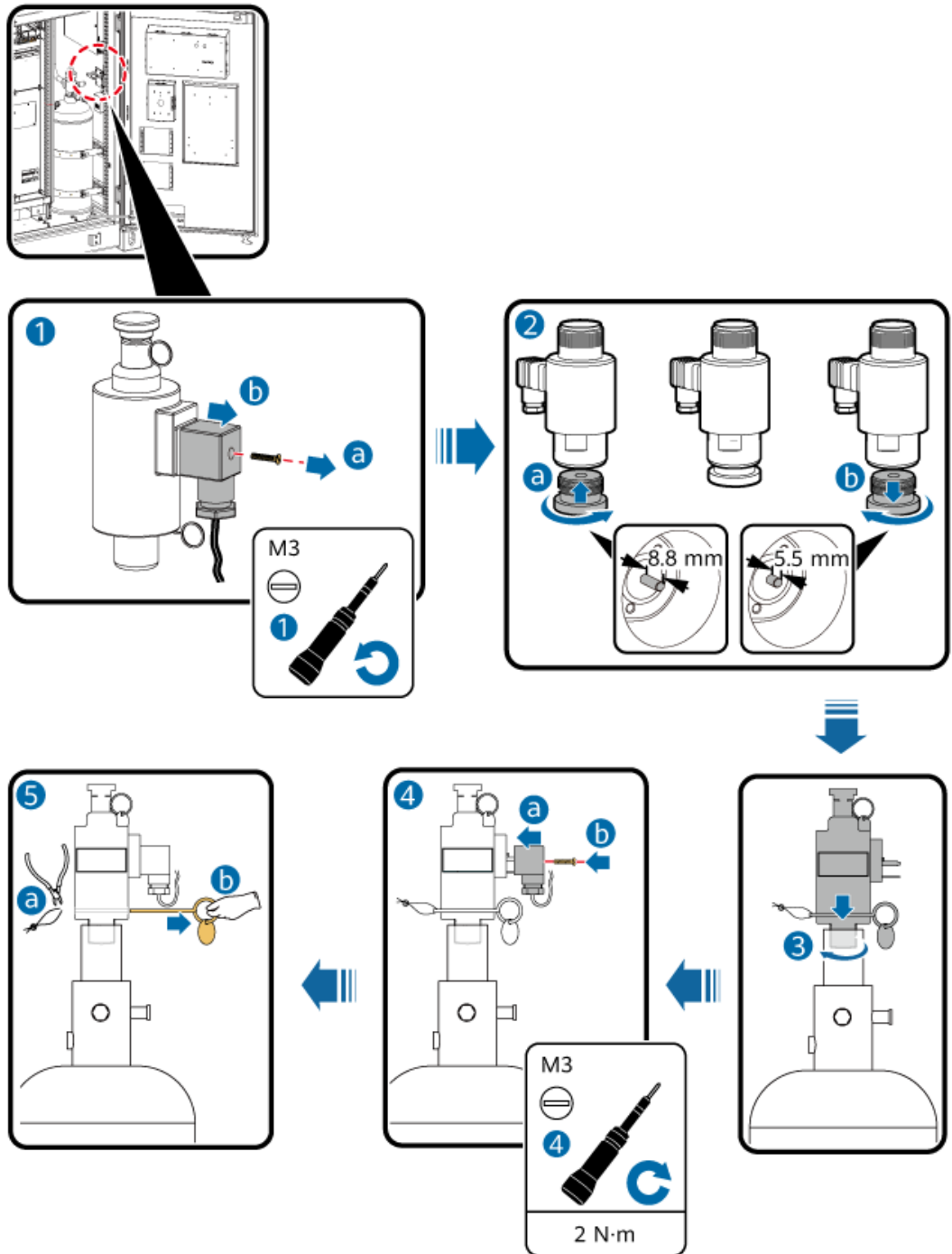

----End

- **Fire cylinder model: NCM38UFAA, 227M38UFAA, SPS020-MS-032B-EN**

Step 1 Take out the solenoid valve from the control unit cabin and reset the solenoid valve.

If the solenoid valve is activated, perform the following steps to reset the solenoid valve.

 **NOTE**

- The solenoid valve is activated if its ejector pin protrudes by 5.5 mm.
- The solenoid valve is inactivated if its ejector pin protrudes by 8.8 mm.

1. Insert the reset device into the solenoid valve to reset the ejector pin.
2. After resetting, remove the solenoid valve reset device.

Step 2 Tighten the solenoid valve clockwise to the top of the fire cylinder.

Figure 8-4 Installing the solenoid valve

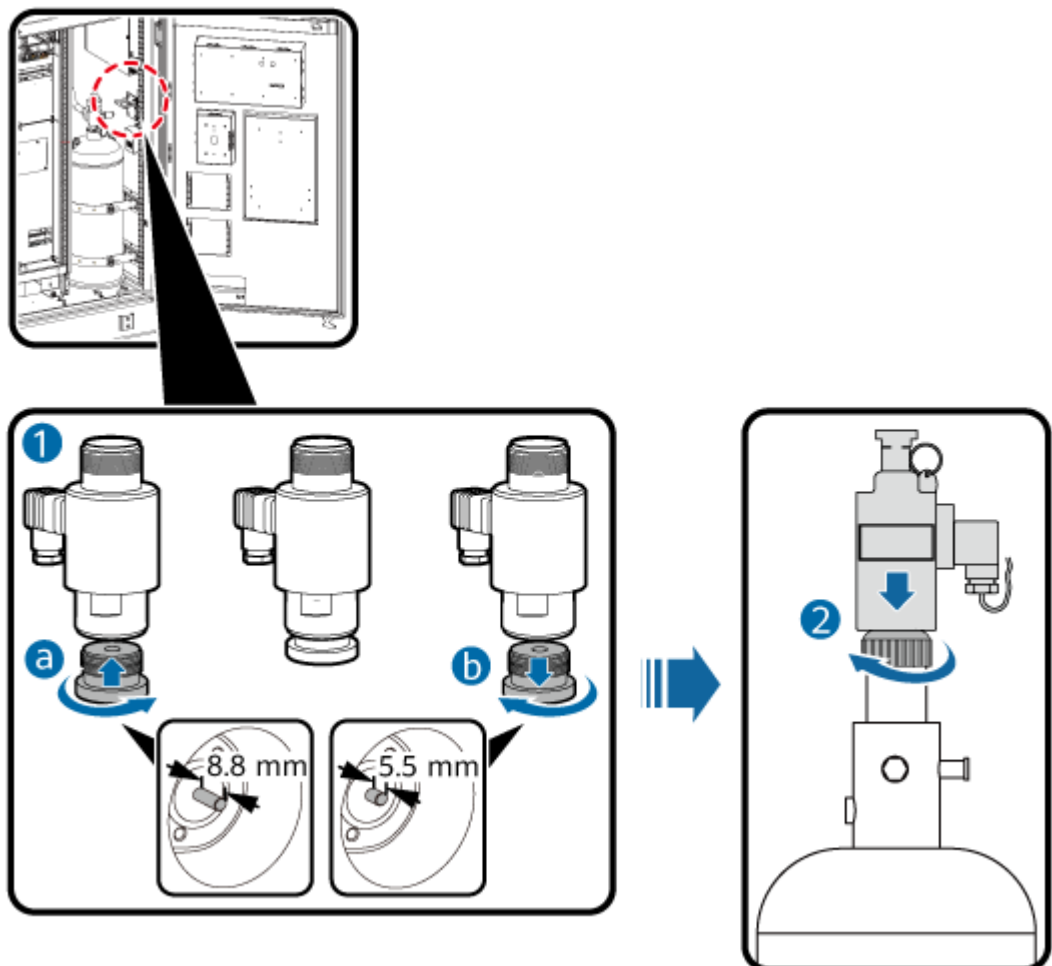

----End

- **Fire cylinder model: P0009438**

Step 1 Remove the nuts and washers from the solenoid valve in the control unit cabin, and take out the solenoid valve.

Step 2 Reinstall the nuts and washers.

Step 3 Install the removed solenoid valve on the stud of the fire cylinder.

Step 4 Tighten the nuts.

 **NOTE**

Nut specifications: hex cap HEX17. Nuts are customized and cannot be replaced with common nuts.

Figure 8-5 Installing the solenoid valve

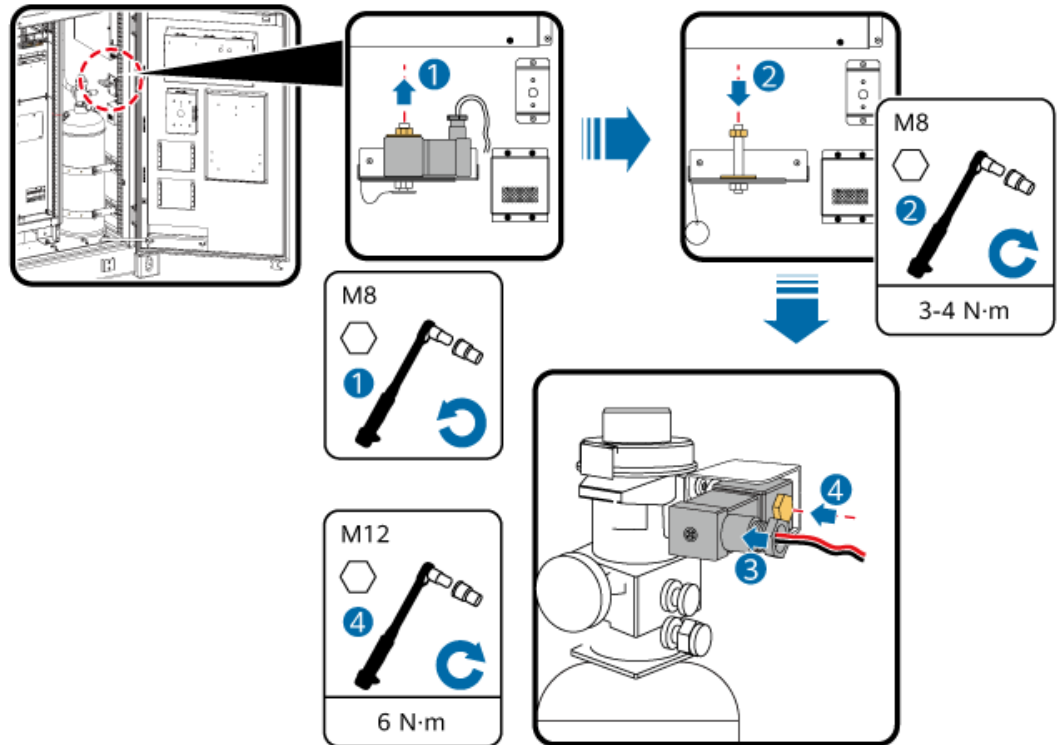

----End

8.3 Powering On the ESS

NOTICE

- Before the equipment is put into operation for the first time, ensure that the parameters are set correctly by professional personnel. Incorrect parameter settings may result in noncompliance with local grid connection requirements and affect the normal operations of the equipment.
 - Before turning on the internal switch of the ESS auxiliary power supply, check that the AC auxiliary power supply voltage is within the normal range.
 - If the ESS has not been used for six months or longer after being installed, it must be checked and tested by professionals before operation.
 - Perform power-on within two weeks after cables are connected. If the ESS has not been powered on for two weeks after cables are connected, replace the desiccants with new ones (Montmorillonite desiccant, 500 g/bag).
 - Before power-on, remove the desiccants from the cabins and dispose of them according to the applicable local waste disposal act.
- The protective film of ESS containers is used to prevent foreign objects from entering the container during storage. Do not remove the protective film before powering on and commissioning the ESS container.
蓝膜是用于存储时防止异物进入，存储时请勿撕毁，需要上电调试前请撕掉。
- Before power-on, remove the blue protective films with the label
 - Do not open the battery cabin door after power-on. Otherwise, the system will shut down.

NOTE

- The switch position diagrams are for reference only, and those of the actual products may vary.
- Switches labeled SPARE are reserved switches.

Procedure

Figure 8-6 Positions of switches in the LUNA2000-2.0MWH-4H1 control unit cabin

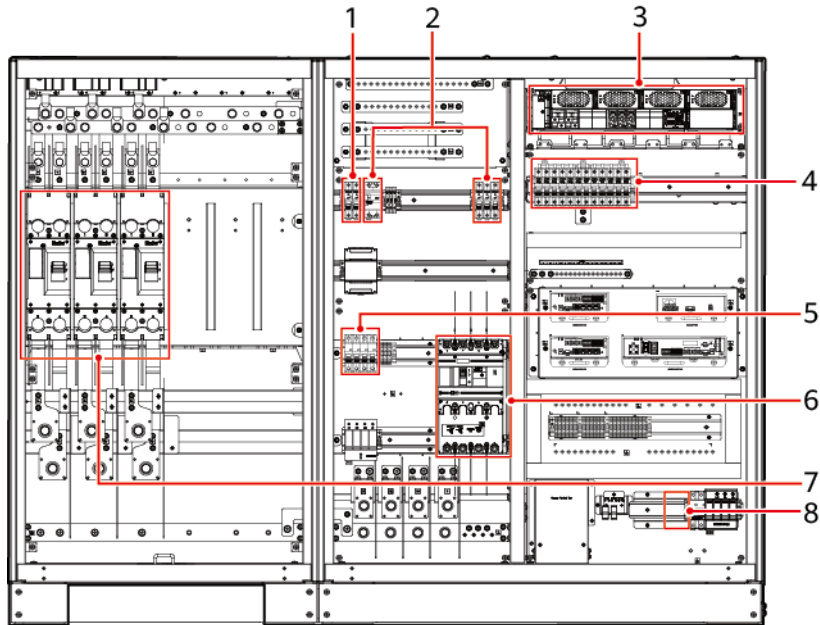

IB04W00104

- | | | | |
|--|---|--|--|
| (1) AC power switch of the air conditioner | (2) Extinguishant control panel switch, lighting/socket switch, adapter switch, and PSU AC input switch | (3) DC input switch, exhaust fan controller switch, and air conditioner switch in the control unit cabin | (4) Battery pack fan switch and Smart Rack Controller switch |
| (5) SPD switch | (6) General AC input switch of the ESS | (7) DC circuit breaker in the control unit | (8) Position for the UPS switch (reserved) |

Figure 8-7 Positions of switches in the LUNA2000-2.0MWH-2H1/LUNA2000-2.0MWH-2H0 control unit cabin (six air conditioners)

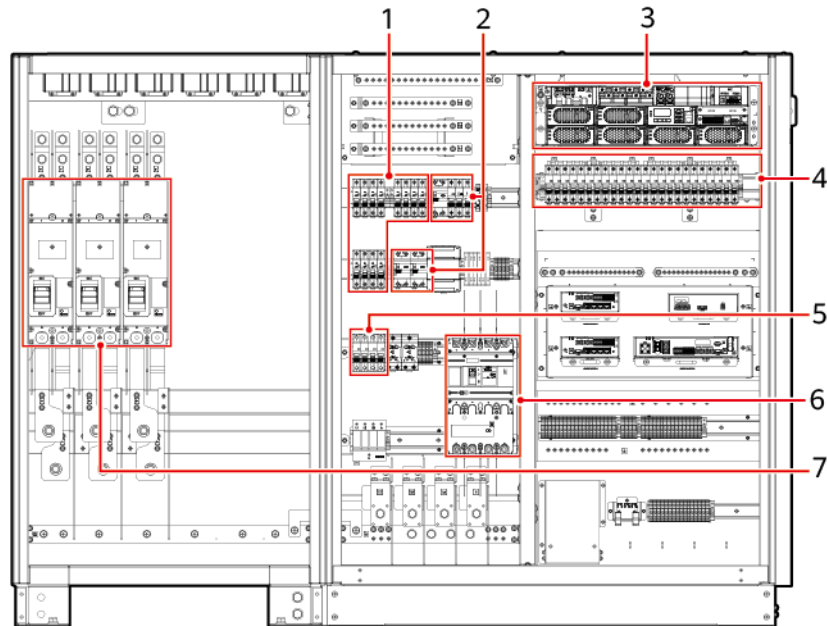

IB04W00050

- | | | | |
|--|---|---|--|
| (1) AC power switch of the air conditioner | (2) Extinguishant control panel switch, lighting switch, 220/230V socket switch, adapter switch, and UPS switch | (3) PSU AC input switch, DC input switch, exhaust fan controller switch, and air conditioner switch in the control unit cabin | (4) Battery pack fan switch and Smart Rack Controller switch |
| (5) SPD switch | (6) General AC input switch of the ESS | (7) DC circuit breaker - in the control unit cabin | |

Figure 8-8 Positions of switches in the LUNA2000-2.0MWH-2H1/ LUNA2000-2.0MWH-HE2H1 control unit cabin (four air conditioners)

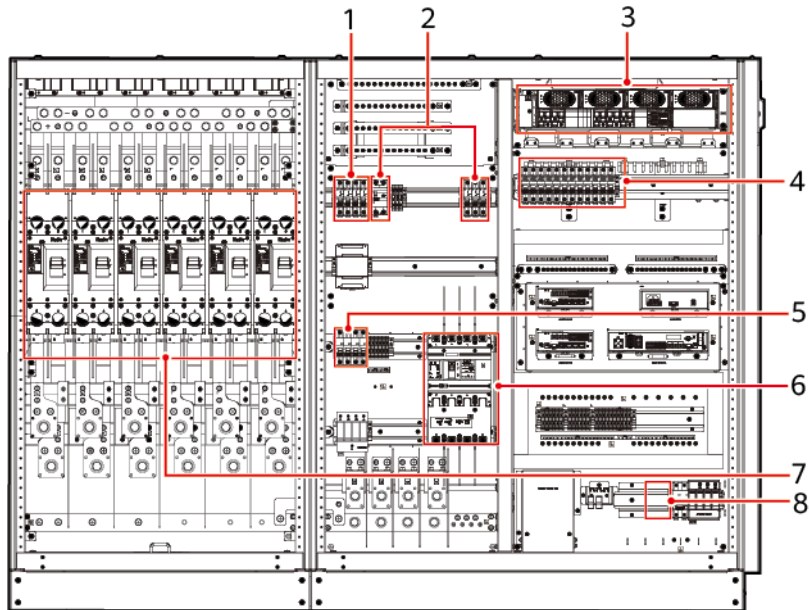

IB04W00115

- | | | | |
|--|---|--|--|
| (1) AC power switch of the air conditioner | (2) Extinguishant control panel switch, lighting/socket switch, adapter switch, and PSU AC input switch | (3) DC input switch, exhaust fan controller switch, and air conditioner switch in the control unit cabin | (4) Battery pack fan switch and Smart Rack Controller switch |
| (5) SPD switch | (6) General AC input switch of the ESS | (7) DC circuit breaker in the control unit | (8) Position for the UPS switch (reserved) cabin |

Figure 8-9 Positions of switches in the LUNA2000-2.0MWH-1H1/LUNA2000-2.0MWH-HE1H1/LUNA2000-2.0MWH-1H0 control unit cabin

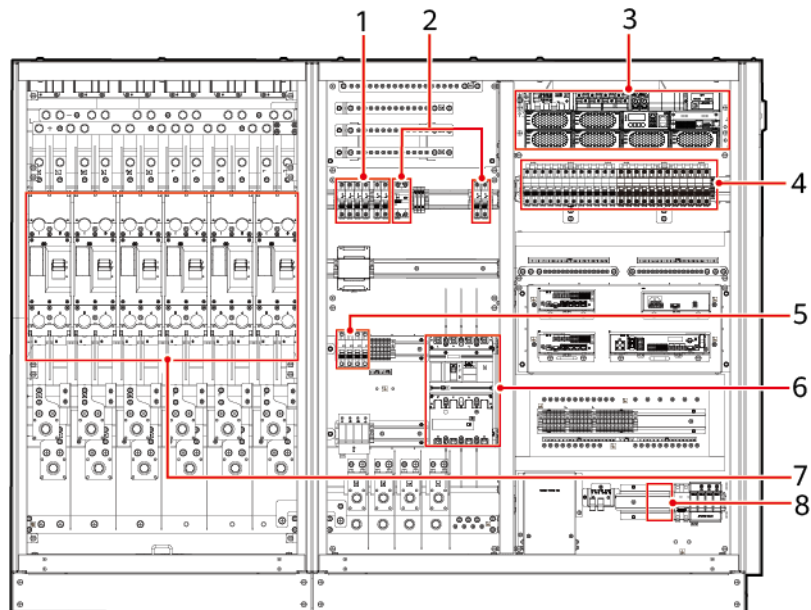

IB04W00115

- | | | | |
|--|---|--|--|
| (1) AC power switch of the air conditioner | (2) Extinguishant control panel switch, lighting/socket switch, adapter switch, and PSU AC input switch | (3) DC input switch, exhaust fan controller switch, and air conditioner switch in the control unit cabin | (4) Battery pack fan switch and Smart Rack Controller switch |
| (5) SPD switch | (6) General AC input switch of the ESS | (7) DC circuit breaker in the control unit cabin | (8) Position for the UPS switch (reserved) |

Figure 8-10 Positions of switches in the LUNA2000-1.0MWH-ES1H1/ LUNA2000-1.0MWH-H1 control unit cabin

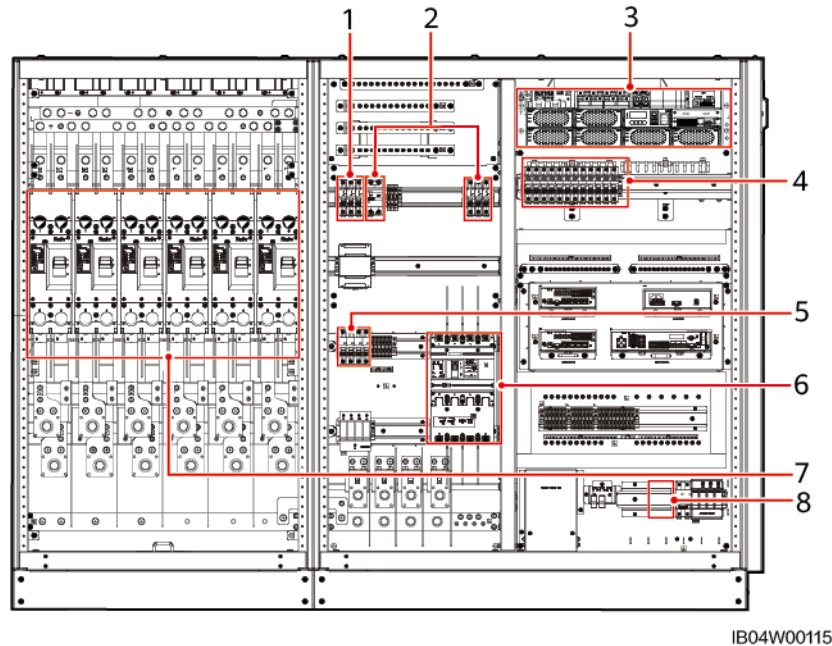

IB04W00115

- | | | | |
|--|---|--|--|
| (1) AC power switch of the air conditioner | (2) Extinguishant control panel switch, lighting/socket switch, adapter switch, and PSU AC input switch | (3) DC input switch, exhaust fan controller switch, and air conditioner switch in the control unit cabin | (4) Battery pack fan switch and Smart Rack Controller switch |
| (5) SPD switch | (6) General AC input switch of the ESS | (7) DC circuit breaker in the control unit cabin | (8) Position for the UPS switch (reserved) |

Step 1 Turn on the DC circuit breakers 1Q1-6Q1 of battery racks in the battery cabins.

Figure 8-11 Positions of the DC circuit breakers of battery racks in the battery cabins

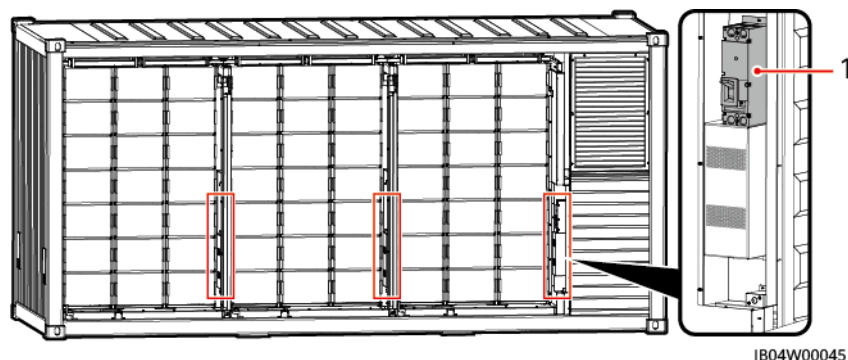

IB04W00045

- (1) Positions of the DC circuit breakers of battery racks in the battery cabins

Step 2 (Optional) Turn on the UPS cable inlet switch 5FCB (as shown by 8 in the switch position diagram).

 NOTE

- The UPS switch position is reserved only in some models. If the UPS switch is needed, install it by yourself.
- Perform this operation only in microgrid or off-grid scenarios.

Step 3 Turn on the SPD switch 2FCB1 (as shown by 5 in the switch position diagram) and check that the SPD display window is green.

Step 4 Turn on the general AC input switch 1QA of the ESS (as shown by 6 in the switch position diagram).

 CAUTION

- After turning on switch 1QA, immediately check that the L1, L2, and L3 phase voltages are 220 V AC/230 V AC on the meter.
- If the phase voltage displayed on the digital meter is 400 V or other voltages, the L1, L2, L3, and neutral wires may be incorrectly connected and you need to check the cables. Do not perform power-on operations before checking the cables. Otherwise, devices such as air conditioners may be damaged.

Step 5 Turn on all switches in the power distribution system of the ESS.

Table 8-1 Switch configurations

Model	Air Conditioner Position in the Battery Cabin	Air Conditioner Switch No.	Battery Pack Fan Switch No.	Smart Rack Controller Switch No.
LUNA2000-2.0MWH-4H1	5/11	3FCB5, 3FCB11	7FCB7–7FCB12	7FCB16–7FCB18
LUNA2000-2.0MWH-2H1	1/3/5/7/9/11	3FCB1, 3FCB3, 3FCB5, 3FCB7, 3FCB9, 3FCB11	7FCB7–7FCB15, 7FCB19–7FCB27	7FCB16, 7FCB17, 7FCB18
LUNA2000-2.0MWH-2H1	1/4/7/10	3FCB1, 3FCB4, 3FCB7, 3FCB10	7FCB7–7FCB12	7FCB16, 7FCB17, 7FCB18
LUNA2000-2.0MWH-2H0	2/4/6/8/10/12	3FCB2, 3FCB4, 3FCB6, 3FCB8, 3FCB10, 3FCB12	7FCB7–7FCB15, 7FCB19–7FCB27	7FCB16, 7FCB17, 7FCB18

Model	Air Conditioner Position in the Battery Cabin	Air Conditioner Switch No.	Battery Pack Fan Switch No.	Smart Rack Controller Switch No.
LUNA2000-2.0MWH-HE2H1	1/4/7/10	3FCB1, 3FCB4, 3FCB7, 3FCB10	7FCB7-7FCB12	7FCB16, 7FCB17, 7FCB18
LUNA2000-2.0MWH-HE1H1	1/3/5/7/9/11	3FCB1, 3FCB3, 3FCB5, 3FCB7, 3FCB9, 3FCB11	7FCB7-7FCB15, 7FCB19-7FCB27	7FCB16, 7FCB17, 7FCB18, 7FCB28, 7FCB29, 7FCB30
LUNA2000-2.0MWH-1H1	1/3/5/7/9/11	3FCB1, 3FCB3, 3FCB5, 3FCB7, 3FCB9, 3FCB11	7FCB7-7FCB15, 7FCB19-7FCB27	7FCB16, 7FCB17, 7FCB18, 7FCB28, 7FCB29, 7FCB30
LUNA2000-2.0MWH-1H1	1/2/4/5/7/8/10/11	3FCB1, 3FCB2, 3FCB4, 3FCB5, 3FCB7, 3FCB8, 3FCB10, 3FCB11	7FCB7-7FCB15, 7FCB19-7FCB27	7FCB16, 7FCB17, 7FCB18, 7FCB28, 7FCB29, 7FCB30
LUNA2000-2.0MWH-1H0	1/2/4/5/7/8/10/11	3FCB1, 3FCB2, 3FCB4, 3FCB5, 3FCB7, 3FCB8, 3FCB10, 3FCB11	7FCB7-7FCB15, 7FCB19-7FCB27	7FCB16, 7FCB17, 7FCB18, 7FCB28, 7FCB29, 7FCB30
LUNA2000-1.0MWH-1H1	1/5/7	3FCB1, 3FCB5, 3FCB7	7FCB7-7FCB15	7FCB16-7FCB18
LUNA2000-1.0MWH-ES1H1	1/5/7	3FCB1, 3FCB5, 3FCB7	7FCB7-7FCB15	7FCB16-7FCB18

1. Turn on the AC power switches of air conditioners (as shown by 1 in the switch position diagram).
2. Turn on adapter switch 5FCB1, extinguishant control panel power switch 5FCB3, and lighting switch 1FB1 in sequence (as shown by 2 in the switch position diagram).
3. Turn on the 220/230 V socket switch 1FB2.

NOTE

Only some models are equipped with socket switches.

- Open the extinguishant control panel and turn on the two internal power switches. (Perform this step only for the JB-QBL-QM210 extinguishant control panel.) Turn off the switch 5FCB3 for the extinguishant control panel, ensure that the extinguishant control panel works properly with battery power supply, and then turn on the switch 5FCB3.

Figure 8-12 Positions of power switches in the extinguishant control panel

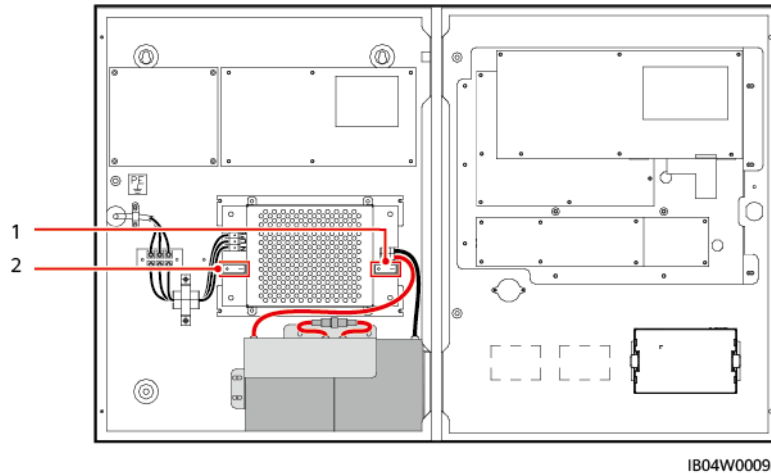

IB04W00093

(1) Power switch on the right in the extinguishant control panel

(2) Power switch on the left in the extinguishant control panel

- Turn on the PSU AC input switch 6FCB1.

NOTE

If a 3 U subrack is configured, the PSU switch is in the subrack. If a 2 U subrack is configured, the PSU switch is at (2) in the switch position diagram.

- On the embedded power subrack, turn on the DC input switches 7FCB1 and (optional) 7FCB2, the exhaust fan controller switches 7FCB4 and 7FCB5, and the air conditioner switch 7FCB6 of the control unit cabin in sequence (as shown by 3 in the switch position diagram).
- Turn on the battery pack fan switches (as shown by 4 in the switch position diagram) in sequence.
- Turn on the Smart Rack Controller switches (as shown by 4 in the switch position diagram).

Step 6 Turn on the DC circuit breakers in the control unit cabin (as shown by 7 in the switch position diagram).

Table 8-2 Switch configurations

Model	Air Conditioner Position in the Battery Cabin	DC Circuit Breaker No. in the Control Unit Cabin
LUNA2000-2.0MWH-4H1	5/11	1Q2-3Q2

Model	Air Conditioner Position in the Battery Cabin	DC Circuit Breaker No. in the Control Unit Cabin
LUNA2000-2.0MWH-2H1	1/3/5/7/9/11	1Q2-3Q2
LUNA2000-2.0MWH-2H1	1/4/7/10	1Q2-6Q2
LUNA2000-2.0MWH-2H0	2/4/6/8/10/12	1Q2-3Q2
LUNA2000-2.0MWH-HE2H1	1/4/7/10	1Q2-6Q2
LUNA2000-2.0MWH-HE1H1	1/3/5/7/9/11	1Q2-6Q2
LUNA2000-2.0MWH-1H1	1/3/5/7/9/11	1Q2-6Q2
LUNA2000-2.0MWH-1H1	1/2/4/5/7/8/10/11	1Q2-6Q2
LUNA2000-2.0MWH-1H0	1/2/4/5/7/8/10/11	1Q2-6Q2
LUNA2000-1.0MWH-1H1	1/5/7	1Q2-6Q2
LUNA2000-1.0MWH-ES1H1	1/5/7	1Q2-6Q2

 **NOTE**

The status of DC circuit breakers in the control unit cabin depends on the actual number of PCSs connected.

----End

9 Deployment and Commissioning (SmartLogger WebUI)

For details about deployment and commissioning in the on-grid scenario, see [LUNA2000-2.0MWH and 1.0MWH Series Utility-Scale Energy Storage On-Grid Solution User Manual](#). For details about deployment and commissioning in the microgrid scenario, see [LUNA2000-2.0MWH and 1.0MWH Series Utility-Scale Energy Storage Microgrid Solution User Manual](#) or [LUNA2000-2.0MWH and 1.0MWH Series Commercial and Industrial Off-Grid Solution User Manual \(Japan\)](#).

NOTICE

It is recommended that the interval between two charge/discharge cycles be less than or equal to five days to ensure that the ESS is in the optimal state.

10 Powering Off the System

10.1 Sending a Shutdown Command on the SmartLogger

Prerequisites

The system has connected to the grid and is running properly.

Procedure

- Step 1** Log in to the SmartLogger WebUI, choose **Maintenance > Connect Device**, and click  to send a shutdown command to the Smart PCS and Smart Rack Controller.

Figure 10-1 Shutdown command



- Step 2** Choose **Monitoring > PCS > Running Info**. Check the device status, active power, and DC voltage to verify that the shutdown is successful.
- Step 3** Choose **Monitoring > CMU > Running Info**. Check the rated power and total output voltage of the PSU to ensure that the shutdown is successful.

Step 4 Choose **Overview > Active Alarm** to view system alarms generated after the shutdown. If any alarm is generated, handle the alarm according to the alarm handling suggestions.

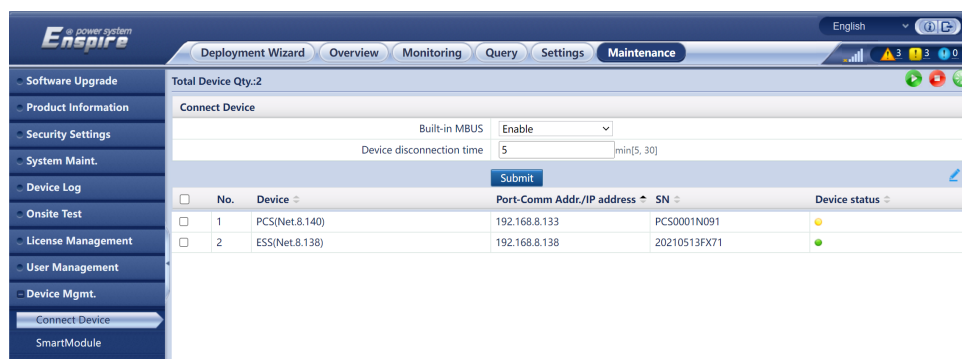
----End

10.2 Powering Off the ESS

Table 10-1 Switch configurations

Model	Air Conditioner Position in the Battery Cabin	Air Conditioner Switch No.	Battery Pack Fan Switch No.	Smart Rack Controller Switch No.
LUNA2000-2.0MWH-4H1	5/11	3FCB5, 3FCB11	7FCB7-7FCB12	7FCB16-7FCB18
LUNA2000-2.0MWH-2H1	1/3/5/7/9/11	3FCB1, 3FCB3, 3FCB5, 3FCB7, 3FCB9, 3FCB11	7FCB7-7FCB15, 7FCB19-7FCB27	7FCB16, 7FCB17, 7FCB18
LUNA2000-2.0MWH-2H1	1/4/7/10	3FCB1, 3FCB4, 3FCB7, 3FCB10	7FCB7-7FCB12	7FCB16, 7FCB17, 7FCB18
LUNA2000-2.0MWH-2H0	2/4/6/8/10/12	3FCB2, 3FCB4, 3FCB6, 3FCB8, 3FCB10, 3FCB12	7FCB7-7FCB15, 7FCB19-7FCB27	7FCB16, 7FCB17, 7FCB18
LUNA2000-2.0MWH-HE2H1	1/4/7/10	3FCB1, 3FCB4, 3FCB7, 3FCB10	7FCB7-7FCB12	7FCB16, 7FCB17, 7FCB18
LUNA2000-2.0MWH-HE1H1	1/3/5/7/9/11	3FCB1, 3FCB3, 3FCB5, 3FCB7, 3FCB9, 3FCB11	7FCB7-7FCB15, 7FCB19-7FCB27	7FCB16, 7FCB17, 7FCB18, 7FCB28, 7FCB29, 7FCB30
LUNA2000-2.0MWH-1H1	1/3/5/7/9/11	3FCB1, 3FCB3, 3FCB5, 3FCB7, 3FCB9, 3FCB11	7FCB7-7FCB15, 7FCB19-7FCB27	7FCB16, 7FCB17, 7FCB18, 7FCB28, 7FCB29, 7FCB30

Model	Air Conditioner Position in the Battery Cabin	Air Conditioner Switch No.	Battery Pack Fan Switch No.	Smart Rack Controller Switch No.
LUNA2000-2.0MWH-1H1	1/2/4/5/7/8/10/11	3FCB1, 3FCB2, 3FCB4, 3FCB5, 3FCB7, 3FCB8, 3FCB10, 3FCB11	7FCB7-7FCB15, 7FCB19-7FCB27	7FCB16, 7FCB17, 7FCB18, 7FCB28, 7FCB29, 7FCB30
LUNA2000-2.0MWH-1H0	1/2/4/5/7/8/10/11	3FCB1, 3FCB2, 3FCB4, 3FCB5, 3FCB7, 3FCB8, 3FCB10, 3FCB11	7FCB7-7FCB15, 7FCB19-7FCB27	7FCB16, 7FCB17, 7FCB18, 7FCB28, 7FCB29, 7FCB30
LUNA2000-1.0MWH-1H1	1/5/7	3FCB1, 3FCB5, 3FCB7	7FCB7-7FCB15	7FCB16-7FCB18
LUNA2000-1.0MWH-ES1H1	1/5/7	3FCB1, 3FCB5, 3FCB7	7FCB7-7FCB15	7FCB16-7FCB18

Step 1 Turn off the DC circuit breakers 1Q1-6Q1 of the battery racks in the ESS battery cabins.

Step 2 Turn off the DC switches in the ESS control unit cabin (as shown by 7 in the switch position diagram in [8.3 Powering On the ESS](#)).

 **NOTE**

The status of DC circuit breakers in the control unit cabin depends on the actual number of PCSs connected.

Step 3 Turn off all switches in the power distribution system of the ESS.

1. Turn off the AC power switches of air conditioners (as shown by 1 in the switch position diagram in [8.3 Powering On the ESS](#)).
2. Turn off the extinguishant control panel switch 5FCB3, open the extinguishant control panel, turn off the internal power switches, and turn off the lighting switch 1FB1, (optional) 220 V socket switch 1FB2, and CMU adapter switch 5FCB1 in sequence (as shown by 2 in the switch position diagram in [8.3 Powering On the ESS](#)).
3. Turn off the battery pack fan switches (as shown by 4 in the switch position diagram in [8.3 Powering On the ESS](#)).
4. Turn off the Smart Rack Controller switches (as shown by 4 in the switch position diagram in [8.3 Powering On the ESS](#)).

5. On the embedded subrack, turn off the DC input switches 7FCB1 and (optional) 7FCB2, the exhaust fan controller switches 7FCB4 and 7FCB5, and the air conditioner switch 7FCB6 of the control unit cabin in sequence (as shown by 3 in the switch position diagram in [8.3 Powering On the ESS](#)).
6. Turn off the PSU AC input switch 6FCB1.

Step 4 Turn off the general AC input switch 1QA of the ESS (as shown by 6 in the switch position diagram in [8.3 Powering On the ESS](#)).

Step 5 If the extinguishant control panel has been powered off for more than 24 hours, the battery switch in the extinguishant control panel must be turned off or cables between the extinguishant control panel and the battery must be disconnected.

Step 6 Turn off the SPD switch 2FCB1 (as shown by 5 in the switch position diagram in [8.3 Powering On the ESS](#)).

Step 7 (Optional) Turn off the UPS cable inlet switch 5FCB (as shown by 8 in the switch position diagram in [8.3 Powering On the ESS](#)).

----End

11 Alarm Reference

For details about the alarm reference, see [LUNA2000-2.0MWH and 1.0MWH Series Smart String ESS Alarm Reference](#).

12 Emergency Handling

If an accident (including but not limited to the following) occurs on the site, ensure the safety of onsite personnel first and contact the Company's service engineers.

Battery Falling or Strong Impact

- If a battery has obvious damage or abnormal odor, smoke, or fire occurs, evacuate the personnel immediately, call emergency services, and contact the professionals. The professionals shall use fire extinguishing facilities to extinguish the fire under safety protection.
- If the appearance is not deformed or damaged, and there is no obvious abnormal odor, smoke, or fire, ensure safety and perform the following operations:
 - Warehouse: Evacuate personnel, transfer the battery to an open and safe place by professionals using mechanical tools, and contact the Company's service engineers. Leave the battery for an hour and ensure that the battery temperature is within the room temperature range (tolerance: $\pm 10^{\circ}\text{C}$) before handling.
 - ESS onsite: Evacuate personnel, close the doors of the ESS, transfer the battery to an open and safe place by professionals using mechanical tools, and contact the Company's service engineers. Leave the battery for an hour before handling.

Flood

- Power off the system if it is safe to do so.
- If any part of the batteries is submerged in water, do not touch the batteries to avoid electric shock.
- Do not use batteries that have been soaked in water. Contact a battery recycling company for disposal.

Fire Alarm Horn/Strobe

When the alarm indicator on the equipment blinks or buzzes:

- Do not approach.

- Do not open the door.
- Stay away immediately.
- Cut off the power supply remotely only when your safety is guaranteed.

Gas Exhaust

- Onsite personal protection: Do not directly face the exhaust vents.
- Post-disaster product maintenance: Contact the Company's service engineers for evaluation.

Extinguishant Release or Fire

- Suggestions for onsite O&M personnel:
 - a. When a fire occurs, evacuate from the building or equipment area, press the fire alarm bell, and immediately call the fire emergency service. Notify the professional firefighters and provide them with relevant product information, including but not limited to battery pack types, ESS capacity, and battery pack location and distribution.
 - b. Do not enter the affected building or equipment area under any circumstances, and do not open the doors of the ESS. Isolate and monitor the site. Keep irrelevant personnel away from the site.
 - c. After calling the fire emergency service, remotely power off the system while ensuring your own safety.
 - d. After professional firefighters arrive, provide relevant product information, including but not limited to battery pack types, ESS capacity, battery pack location and distribution, and user manuals.
 - e. After the fire is extinguished, the site must be handled by professionals in accordance with local laws and regulations. Do not open the doors of the ESS without permission.
 - f. Post-disaster product maintenance: Contact the Company's service engineers for evaluation.
- Suggestions for professional firefighters:
 - a. For product information, see the information provided by O&M personnel, including but not limited to battery pack types, ESS capacity, battery pack location and distribution, and user manuals.
 - b. Do not open the doors of the ESS before it is deemed safe by professionals.
 - c. Follow local fire fighting regulations.

13 FAQ

13.1 (Optional) How Do I Level the ESS When Doors Cannot Be Opened or Closed?

 **NOTE**

This procedure applies only to some models.

Step 1 Use a jack to support the ESS.

Jack specification: 30 t

Position requirements: on the control unit cabin side or its opposite side (the short side of the ESS container).

 **NOTE**

Wood sleepers can be used in the following circumstances.

- Insufficient jack height: Place wood sleepers underneath the jack.
- Natural ground surface: Use wood sleepers to extend contact area.

Step 2 Adjust the height using leveling washers from the control unit cabin.

Scenario 1: The upper part of the lock tongue interferes with the upper surface of the lock base.

Use leveling washers to raise the ESS by 5–10 mm on the foundation under the door hinge.

 **NOTE**

The raising height leveling washers may vary according to the actual conditions.

Figure 13-1 The upper part of the lock tongue interfering with the upper surface of the lock base

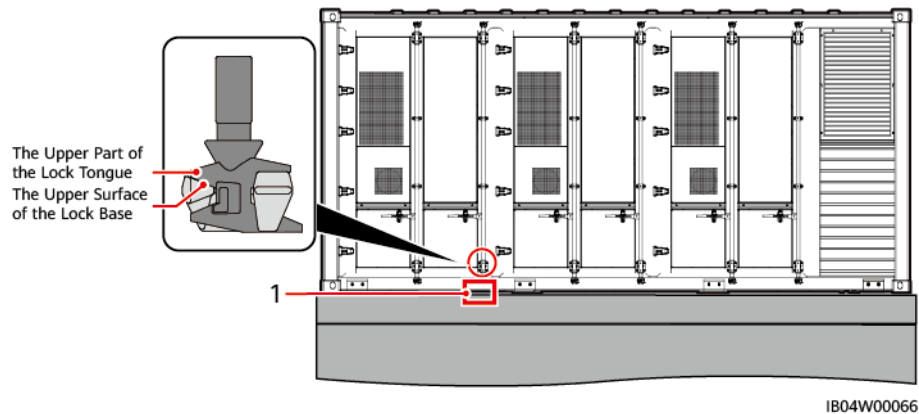

(1) Position of leveling washers

Scenario 2: The lower part of the lock tongue interferes with the lower surface of the lock base.

Use leveling washers to raise the ESS by 5–10 mm on the foundation under the lock base farthest to the door hinge.

Figure 13-2 The lower part of the lock tongue interfering with the lower surface of the lock base.

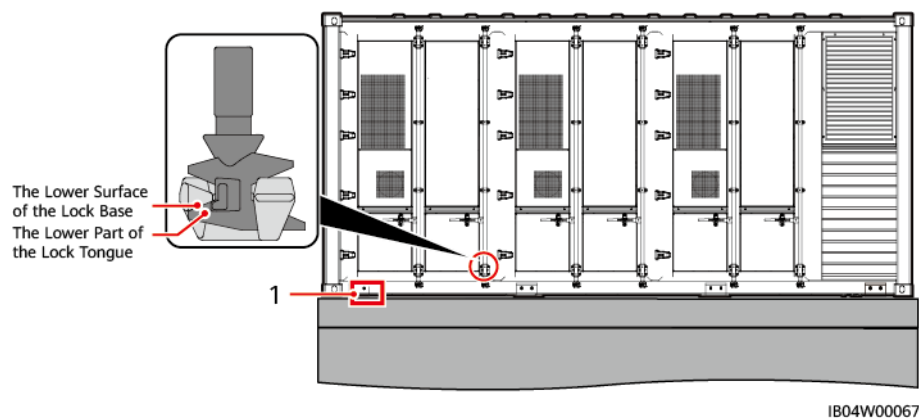

(1) Position of leveling washers

----End

13.2 How Do I Ensure that the Solenoid Valve Is Not Activated?

Fire cylinder model: GQQ40/2.5, NCM38UFAA, 227M38UFAA, and SPS020-MS-032B-EN

Step 1 Check whether the solenoid valve is not activated.

Step 2 If it is activated, reset it. The reset procedure is as follows:

1. Insert the reset device into the solenoid valve to reset the ejector pin.
2. After resetting, remove the solenoid valve reset device.

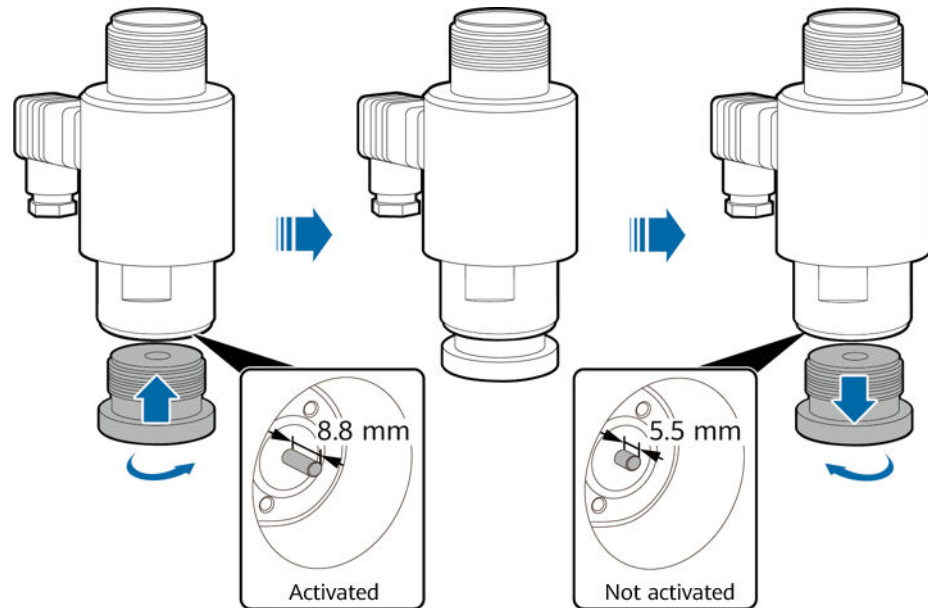

----End

- **Fire cylinder model: P0009438**

- Step 1** Check whether the solenoid valve is not activated. If the test contactor is closed at the bottom of the stud, the solenoid valve is activated. If the test contactor fails to be closed after being lifted to the bottom of the stud, the solenoid valve is not activated.
- Step 2** If the solenoid valve is not activated, log in to the CMU to check whether **Fire Alarm** (alarm ID: 3802) is reported.
- Step 3** If the preceding alarm is reported, power off the extinguishant control panel and disconnect the lead-acid battery cable. If the preceding alarm is not reported, contact the Company's technical support.

----End

13.3 How Do I Connect the ESS to the Smart PV Management System?

- Step 1** Enter `https://SmartPVMS` IP address: 31943 in the address box of a browser, and press **Enter**. The login page is displayed.
- Step 2** Enter the username or email address, and password, and click **Log In**.



----End

13.4 How Do I Create a Plant?

Step 1 Choose **Plants > Plant Management** from the main menu.

Step 2 On the **Plant Management** page, click **Add Plant**.

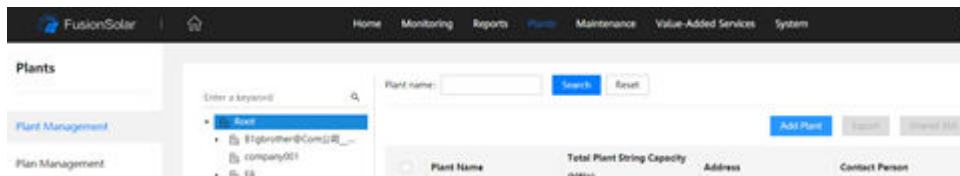

Step 3 Perform the next step as prompted.

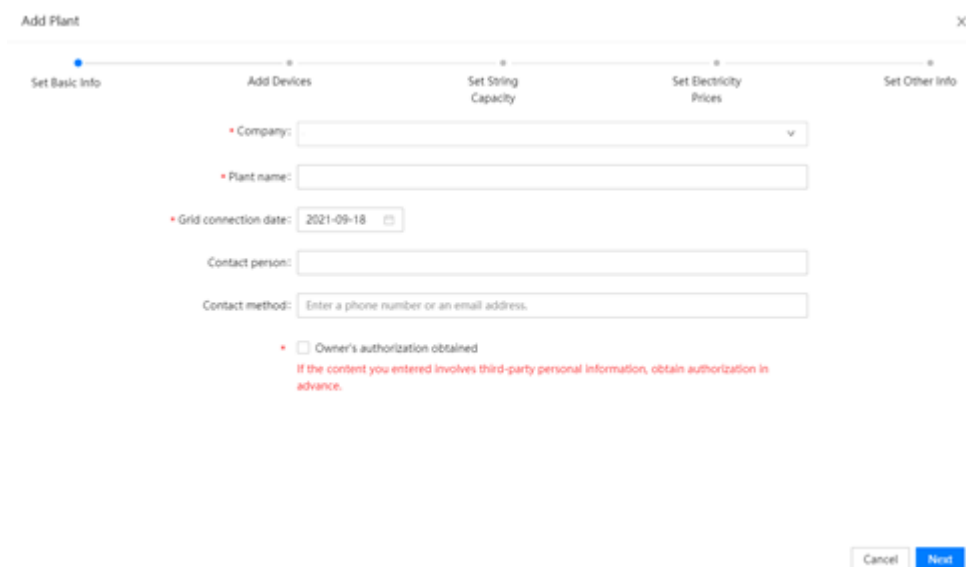

----End

13.5 Why Does the PSU Not Start After the Water and Fire Alarms Are Cleared

Step 1 Choose **Monitoring > Running Param. > Fire suppression > Starting up** on the SmartLogger WebUI.

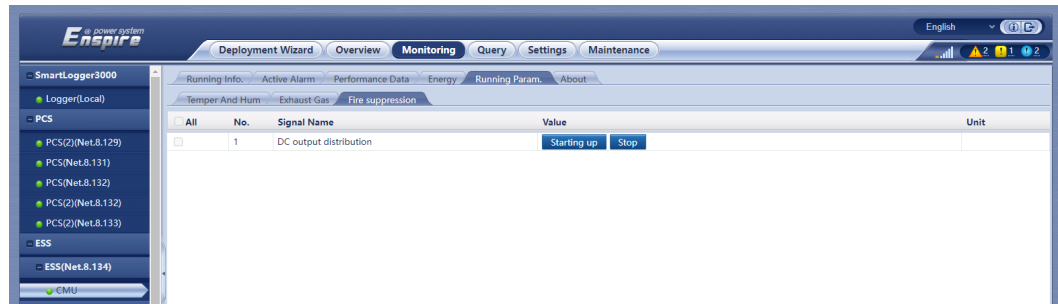

----End

13.6 What Should I Do If the ESU Cable Connection Detection Abnormal Alarm Is Generated on the WebUI?

Step 1 Press the reset button (🔄) in the upper right corner of the ESU page. The ESU restarts cable connection detection.

📖 NOTE

If the alarm persists, contact your vendor or technical support.

----End

13.7 How Do I Perform a Dielectric Voltage Withstand Test on the AC Side of an ESS?

Prerequisites

1. Turn on the main switch of the AC circuit breaker, as shown by (1) in the figure. Turn off other switches.

📖 NOTE

Make sure the power switch of the 3 U or 2 U subrack is off, as shown by (2) in the figure.

2. Remove the SMU from the 3 U or 2 U subrack, as shown by (3) in the figure.
3. Disconnect the power meter fuse, as shown by (4) in the figure.
4. Disconnect the main neutral wire, as shown by (5) in the figure.

Figure 13-3 3U subrack positions

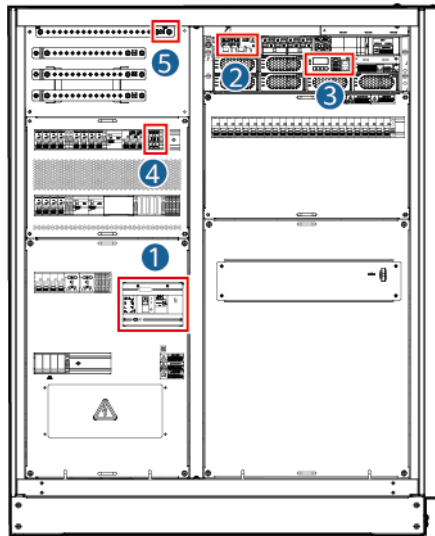

IB04W00097

Figure 13-4 2U subrack positions

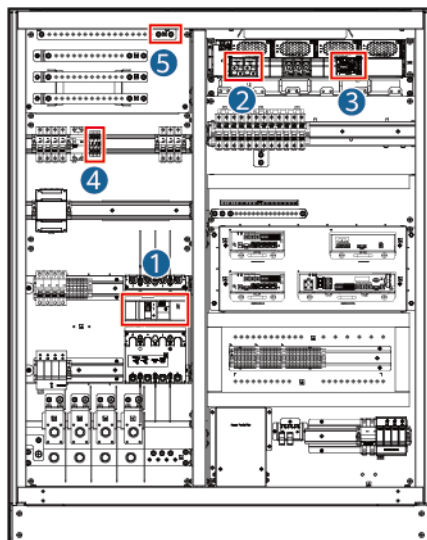

IB04W00097

Test Instrument

Withstand voltage tester

Test Items and Criteria

No.	Test Item	Procedure	Criteria
1	Withstand voltage of the main ground after L1, L2, L3, and N are short-circuited	<ol style="list-style-type: none"> 1. Short-circuit L1, L2, L3, and N. 2. Select the withstand voltage test function for the tester. Connect one end to the short-circuit point of the phase wire and the other end to the main ground point. Set the dielectric withstand voltage to 2121 V DC, rise time to 10s, and hold time to 60s. 	<ul style="list-style-type: none"> • The leakage current during the test is less than 10 mA. • No breakdown or flashover occurs during the test.
2	Main ground insulation resistance after L1, L2, L3, and N are short-circuited	<ol style="list-style-type: none"> 1. Short-circuit L1, L2, L3, and N. 2. Select the insulation resistance test function for the tester. Connect one end of the tester to the short-circuit point of the phase wire and the other end to the main ground point. Set the test voltage to 1 kV DC and record the test resistance. 	<ul style="list-style-type: none"> • The test voltage is 1 kV. • The stable insulation resistance is greater than or equal to 1 MΩ.

Note: If the result of the first test does not meet the requirements, perform the test again following the prerequisites. If the test result still fails to meet the requirements, contact the Company's service engineers immediately.

Follow-up Procedure

Remove the short-circuit cable and restore all switches to factory settings.

13.8 How Do I Remove Ice When the Cabin Door Is Frozen and Cannot Be Opened?

CAUTION

Do not remove ice or open the door in harsh weather conditions such as lightning, rain, snow, sandstorm, and level 6 or stronger wind.

Procedure

Use a rubber mallet to knock the ice off the door lock, door frame, and hinge (see the areas between the red solid lines and dotted lines in [Figure 13-5](#)). After the ice is removed completely, open the cabin door.

 **CAUTION**

- During ice removal, keep away from components that are prone to damage or may affect system operations, such as air conditioners, air conditioner filler panels, water-retaining edges, extinguishant release button, extinguishant abort button, extinguishant release indicator, fire alarm horn/strobe, and ESS abort buttons. For details, see the areas within the red solid lines in [Figure 13-5](#).
 - Use a rubber mallet to knock the ice off to avoid paint damage.
-

Figure 13-5 Knocking the ice off the areas between the red solid lines and the red dotted lines

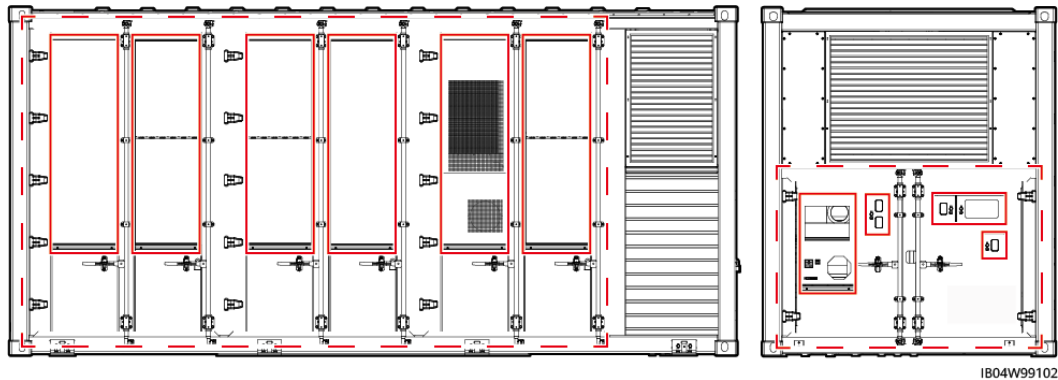

14 Technical Specifications

Table 14-1 LUNA2000-1.0MWH series technical specifications

Item	LUNA2000-1.0MWH-1H1	LUNA2000-1.0MWH-ES1H1
Rated voltage on the bus side of the Smart Rack Controller	1250 V	1250 V
Maximum voltage on the bus side of the Smart Rack Controller	1500 V	1500 V
Smart Rack Controller model	ESC360KW-F	ESC360KW-F
Smart Rack Controller configuration	One battery rack is configured with a Smart Rack Controller.	One battery rack is configured with a Smart Rack Controller.
Rated voltage of a battery rack	1209.6 V	1209.6 V
Voltage range of a battery rack	1020–1365 V	1020–1365 V
Battery pack model	ESM57280AS1	ESM57280AS1
Battery pack configuration per rack	One battery rack is configured with 21 battery packs.	One battery rack is configured with 21 battery packs.
Nominal capacity of a battery rack	338.7 kWh	338.7 kWh
Nominal power	3 x 339 kW	3 x 339 kW
Rated bus charge/discharge current	3 x 271 A	3 x 271 A
Maximum bus charge/discharge current	3 x 280 A	3 x 280 A
Maximum battery current	280 A	280 A
Charge/Discharge rate	≤ 1C @ 40°C	≤ 1C @ 40°C
Intra-rack balancing mode	Pack-level active balancing	Pack-level active balancing

Item	LUNA2000-1.0MWH-1H1	LUNA2000-1.0MWH-ES1H1
Number of battery racks per ESS	3	3
Nominal battery capacity per ESS	1016 kWh	936 kWh
ESS container dimensions (H x W x D)	20 ft: 2896 mm x 6058 mm x 2438 mm	20 ft: 2896 mm x 6058 mm x 2438 mm
Weight	≤ 20 t	≤ 20 t
IP rating	IP55	IP55
Operating temperature range	-30°C to +55°C	-30°C to +55°C
Storage temperature range	-40°C to +60°C	-40°C to +60°C
Operating humidity range	0%–100% (non-condensing)	0%–100% (non-condensing)
DC surge protection	Type II	Type II
Maximum operating altitude	4000 m	4000 m
Battery temperature control mode	Industrial air conditioning	Industrial air conditioning
Number of air conditioners in the battery cabin	3	3
Fire suppression system	FM-200 or FK-5-1-12	FM-200 or FK-5-1-12
System communications interface	Ethernet/Optical fiber (standard configuration)	Ethernet/Optical fiber (standard configuration)
System communications protocol	Modbus TCP	Modbus TCP

Table 14-2 LUNA2000-2.0MWH series (320 Ah cell) technical specifications

Item	LUNA2000-2.0MWH-1H0	LUNA2000-2.0MWH-2H0
Rated voltage on the bus side of the Smart Rack Controller	1200 V	1200 V
Maximum voltage on the bus side of the Smart Rack Controller	1500 V	1500 V
Smart Rack Controller model	ESC360KW-F	ESC360KW-F
Smart Rack Controller configuration	One battery rack is configured with a Smart Rack Controller.	Two battery racks are configured with a Smart Rack Controller.

Item	LUNA2000-2.0MWH-1H0	LUNA2000-2.0MWH-2H0
Rated voltage of a battery rack	1075.2 V	1075.2 V
Voltage range of a battery rack	907–1227 V	907–1227 V
Battery pack model	ESM51320AS1	ESM51320AS1
Battery pack configuration per rack	One battery rack is configured with 21 battery packs.	One battery rack is configured with 21 battery packs.
Nominal capacity of a battery rack	344.1 kWh	344.1 kWh
Nominal power	6 x 344 kW	3 x 344 kW
Rated bus charge/discharge current	6 x 287 A	3 x 287 A
Maximum bus charge/discharge current	6 x 320 A	3 x 320 A
Maximum battery current	320 A	160 A
Charge/Discharge rate	≤ 1C @ 40°C	≤ 0.5C @ 40°C
Intra-rack balancing mode	Pack-level active balancing	Pack-level active balancing
Number of battery racks per ESS	6	6
Nominal battery capacity per ESS	2064 kWh	2064 kWh
ESS container dimensions (H x W x D)	20 ft: 2896 mm x 6058 mm x 2438 mm	20 ft: 2896 mm x 6058 mm x 2438 mm
Weight	≤ 30 t	≤ 30 t
IP rating	IP55	IP55
Operating temperature range	–30°C to +55°C	–30°C to +55°C
Storage temperature range	–40°C to +60°C	–40°C to +60°C
Operating humidity range	0%–100% (non-condensing)	0%–100% (non-condensing)
DC surge protection	Type II	Type II
Maximum operating altitude	4000 m	4000 m
Battery temperature control mode	Industrial air conditioning	Industrial air conditioning
Number of air conditioners in the battery cabin	8	6
Fire suppression system	FM-200 or FK-5-1-12	FM-200 or FK-5-1-12

Item	LUNA2000-2.0MWH-1H0	LUNA2000-2.0MWH-2H0
System communications interface	Ethernet/Optical fiber (standard configuration)	Ethernet/Optical fiber (standard configuration)
System communications protocol	Modbus TCP	Modbus TCP
Note [1]: To use the product at an altitude higher than 4000 m, contact technical support.		

Table 14-3 LUNA2000-2.0MWH series (280 Ah cell) technical specifications

Item	LUNA2000-2.0MWH-4H1	LUNA2000-2.0MWH-1H1	LUNA2000-2.0MWH-2H1	LUNA2000-2.0MWH-HE2H1	LUNA2000-2.0MWH-HE1H1
Rated voltage on the bus side of the Smart Rack Controller	1250 V	1250 V	1250 V	1250 V	1250 V
Maximum voltage on the bus side of the Smart Rack Controller	1500 V	1500 V	1500 V	1500 V	1500 V
Smart Rack Controller model	ESC360KW-F	ESC360KW-F	ESC360KW-F	ESC360KW-F	ESC360KW-F
Smart Rack Controller configuration	Two battery racks are configured with a Smart Rack Controller.	One battery rack is configured with a Smart Rack Controller.	Two battery racks are configured with a Smart Rack Controller.	Two battery racks are configured with a Smart Rack Controller.	One battery rack is configured with a Smart Rack Controller.
Rated voltage of a battery rack	1209.6 V	1209.6 V	1209.6 V	1094.4 V	1094.4 V
Voltage range of a battery rack	1020–1365 V	1020–1365 V	1020–1365 V	923–1235 V	923–1235 V
Battery pack model	ESM57280AS1	ESM57280AS1	ESM57280AS1 or ESM57280AS5	ESM57280AS1	ESM57280AS1

Item	LUNA2000-2.0MWH-4H1	LUNA2000-2.0MWH-1H1	LUNA2000-2.0MWH-2H1	LUNA2000-2.0MWH-HE2H1	LUNA2000-2.0MWH-HE1H1
Battery pack configuration per rack	One battery rack is configured with 21 battery packs.	One battery rack is configured with 21 battery packs.	One battery rack is configured with 21 or 19 battery packs.	One battery rack is configured with 19 battery packs.	One battery rack is configured with 19 battery packs.
Nominal capacity of a battery rack	338.7 kWh	338.7 kWh	338.7 kWh	306.4 kWh	306.4 kWh
Nominal power	3 x 169.5 kW	6 x 339 kW	3 x 339 kW	3 x 306 kW	6 x 306 kW
Rated bus charge/discharge current	3 x 135.5 A	6 x 271 A	3 x 271 A	3 x 245 A	6 x 245 A
Maximum bus charge/discharge current	3 x 168 A	6 x 280 A	3 x 280 A	3 x 280 A	6 x 280 A
Maximum battery current	140 A	280 A	ESM57280AS1 : 140 A ESM57280AS5 : 145 A	140 A	280 A
Charge/Discharge rate	≤ 0.27C @ 50°C	≤ 1C @ 40°C	≤ 0.5C @ 40°C	≤ 0.5C @ 40°C	≤ 1C @ 40°C
Intra-rack balancing mode	Pack-level active balancing	Pack-level active balancing	Pack-level active balancing	Pack-level active balancing	Pack-level active balancing
Number of battery racks per ESS	6	6	6	6	6
Nominal battery capacity per ESS	2032 kWh	2032 kWh	2032 kWh	1838 kWh	1838 kWh
ESS container dimensions (H x W x D)	20 ft: 2896 mm x 6058 mm x 2438 mm	20 ft: 2896 mm x 6058 mm x 2438 mm	20 ft: 2896 mm x 6058 mm x 2438 mm	20 ft: 2896 mm x 6058 mm x 2438 mm	20 ft: 2896 mm x 6058 mm x 2438 mm
Weight	≤ 30 t	≤ 30 t	≤ 30 t	≤ 30 t	≤ 30 t
IP rating	IP55	IP55	IP55	IP55	IP55

Item	LUNA2000-2.0MWH-4H1	LUNA2000-2.0MWH-1H1	LUNA2000-2.0MWH-2H1	LUNA2000-2.0MWH-HE2H1	LUNA2000-2.0MWH-HE1H1
Operating temperature range	-30°C to +55°C	-30°C to +55°C	-30°C to +55°C	-30°C to +55°C	-30°C to +55°C
Storage temperature range	-40°C to +60°C	-40°C to +60°C	-40°C to +60°C	-40°C to +60°C	-40°C to +60°C
Operating humidity range	0%–100% (non-condensing)	0%–100% (non-condensing)	0%–100% (non-condensing)	0%–100% (non-condensing)	0%–100% (non-condensing)
DC surge protection	Type II	Type II	Type II	Type II	Type II
Maximum operating altitude	4000 m	4000 m	4000 m	4000 m ^[1]	4000 m ^[1]
Battery temperature control mode	Industrial air conditioning	Industrial air conditioning	Industrial air conditioning	Industrial air conditioning	Industrial air conditioning
Number of air conditioners in the battery cabin	2	8 or 6	6 or 4	4	6
Fire suppression system	FM-200 or FK-5-1-12	FM-200 or FK-5-1-12	FM-200 or FK-5-1-12	FK-5-1-12	FK-5-1-12
System communications interface	Ethernet/Optical fiber (standard configuration)	Ethernet/Optical fiber (standard configuration)	Ethernet/Optical fiber (standard configuration)	Ethernet/Optical fiber (standard configuration)	Ethernet/Optical fiber (standard configuration)
System communications protocol	Modbus TCP	Modbus TCP	Modbus TCP	Modbus TCP	Modbus TCP

Note [1]: To use the product at an altitude higher than 4000 m, contact technical support.

A Operations on the CMU WebUI

A.1 CMU WebUI Operations

NOTICE

- This document takes the WebUI screenshots of the LUNA2000C V100R023C00 for example. The screenshots are for reference only.
- The parameter names, value ranges, and default values are subject to change. The actual display may vary.

A.1.1 WebUI Layout



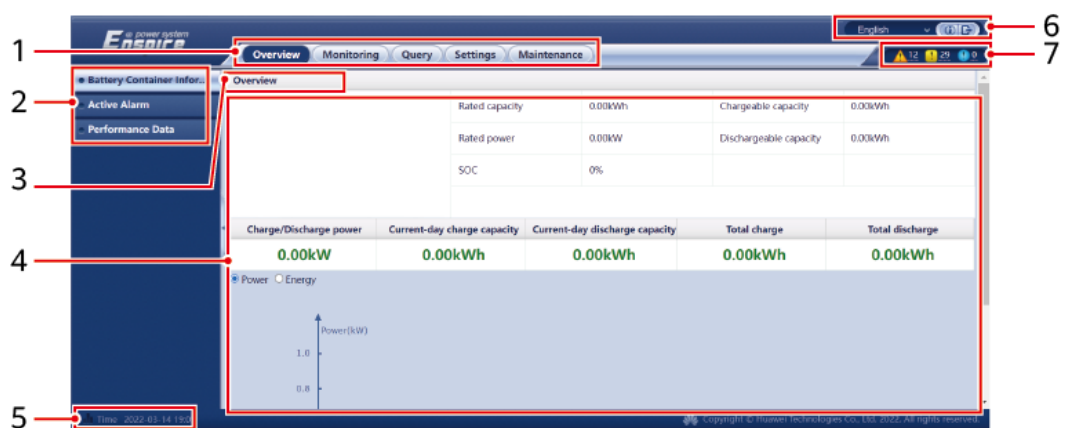









Figure A-1 WebUI layout







No.	Function	Description
1	First-level menu	Specifies the first-level menu for subsequent operations over the WebUI.

No.	Function	Description
2	Second-level menu	Allows users to choose the device to be queried or the parameter to be set under the second-level menu.
3	Third-level menu	Allows users to choose a third-level menu to access the query or setting page.
4	Details page	Displays details of the queried information or parameter setting.
5	System time	Displays the current system time.
6	Display language	Allows users to select the display language or choose to log out.
7	Alarm icon	Displays the severities and number of active system alarms. You can click a number to access the alarm page.

A.1.2 Icon Description

Icon	Description	Icon	Description
	Click the About icon to query the WebUI version information.		Click the Drop-down icon to select a parameter or time.
	Click the Exit icon to log out.		Alarms are classified into major, minor, and warning ones. Click the Alarm icon to query an alarm.
	Click the Increase/Decrease icon to adjust time.		Click the Startup icon to start the device.
	The Select icon indicates that a parameter is selected.		Click the Stop icon to shut down the device.
	The Select icon indicates that a parameter is not selected. Click the icon to select a parameter.		Click the Reset icon to reset the device.
	Collapse icon and Expand icon.		The CMU is in Running state.

Icon	Description	Icon	Description
	<ul style="list-style-type: none"> The CMU is in Disconnection state. If the CMU is in Disconnection state, its parameters cannot be set. 		The CMU is in Loading state.
	The CMU is in Initializing, Power-off, Idle or other states in which the CMU is not feeding power into the grid.		Ascending order or descending order icon. Click the icon to sort the items in ascending or descending order for the corresponding column.

A.1.3 WebUI Menus

Table A-1 WebUI menus

Main Menu	Second-Level Menu	Third-Level Menu	Function
Overview	ESS information	-	Queries ESS information.
	Active Alarm	-	Queries active alarms.
	Performance Data	-	Queries or exports performance data.
Monitoring	CMU	Running Info.	Queries the running information.
		Active Alarm	Queries active alarms.
		Running Param.	Sets running parameters.
		Module(M1)	Queries the expansion module.
		IO Board	Queries black-start information.
		About	Queries the version and communication information.
Query	Alarm History	-	Query historical alarms.
	Operation Log	-	Queries operation logs.
	Export Data	-	Exports historical alarms, energy yields, operation logs, and power grid scheduling data.

Main Menu	Second-Level Menu	Third-Level Menu	Function
Settings	User Param.	Date&Time	Sets the date and time.
	Comm. Param.	Wireless Network	<ul style="list-style-type: none"> • Sets parameters for the built-in WLAN. • Sets mobile data (4G/3G/2G) parameters.
		Wired Network	Sets wired network parameters.
		RS485	Sets RS485 parameters.
		Modbus TCP	Sets Modbus TCP parameters.
	Other parameters	-	-
Maintenance	Software Upgrade	-	Upgrades the CMU software.
	Product Information	-	Queries product information.
	Security Settings	-	<ul style="list-style-type: none"> • Changes the user password. • Sets the automatic logout time. • Uploads a network security certificate. • Updates the key. • Sets the lockout duration and number of times an account is locked upon login failure. • Sets the certificate alarm time. • Uploads a SmartModule security certificate. • Enables or disables communication using an expired SmartModule certificate.
	System Maint.	-	<ul style="list-style-type: none"> • Resets the system. • Restores the factory settings. • Clears data. • Exports all configuration files. • Imports all configuration files. • Clears cache.
	Device Log	-	Exports device logs.
	Onsite Test	-	Performs a charge/discharge test on the battery rack.
	User Management	-	Adds, modifies, or deletes a user.

Main Menu	Second-Level Menu	Third-Level Menu	Function
	Device Mgmt.	Connect Device	<ul style="list-style-type: none"> Adds or removes a device. Imports or exports configurations.
		SmartModule	<ul style="list-style-type: none"> Removes the SmartModule. Sets the authentication password.
		Clear Alarm	Clears device alarms.

A.2 Maintenance Operations

A.2.1 Preparations and WebUI Login

Prerequisites

- The operating system of Windows 7 or later is supported.
- Browser: Chrome 52, Firefox 58, or Internet Explorer 9, or a later version is recommended.

Procedure

Step 1 Connect the network cable between the network port of the PC and the WAN or LAN port of the CMU.

Step 2 Set the IP address for the PC on the same network segment as the CMU IP address.

- Scenario where the CMU is not connected to the SACU

Connected Port	IP Setting	CMU Default Value	Example PC Setting
LAN port	IP address	192.168.8.10	192.168.8.11
	Subnet mask	255.255.255.0	255.255.255.0
	Default gateway	192.168.8.1	192.168.8.1
WAN port	IP address	192.168.0.10	192.168.0.11
	Subnet mask	255.255.255.0	255.255.255.0
	Default gateway	192.168.0.1	192.168.0.1

- Scenario where the CMU is connected to the SACU

SACU LAN Port IP Address	CMU WAN Port IP Address	CMU LAN Port IP Address
192.168.8.10	192.168.8.XXX	192.168.3.10
XXX.XXX.XXX.XXX ^a	XXX.XXX.XXX.XXX ^a	192.168.8.10

Note a: When you set the IP address of the SACU LAN port, the IP address of the CMU WAN port changes with the IP address of the SACU LAN port. You can view the IP address on the SACU WebUI or SUN2000 app.

Step 3 Set LAN parameters.

NOTICE

- If the CMU is connected to a LAN and a proxy server has been configured, you need to cancel the proxy server configurations.
- If the CMU is connected to the Internet and the PC is connected to the LAN, do not cancel the proxy server settings.

1. Open Internet Explorer.
2. Choose **Tools > Internet Options**.
3. Click the **Connections** tab and then click **LAN settings**.
4. Clear **Use a proxy server for your LAN**.

Figure A-2 LAN settings

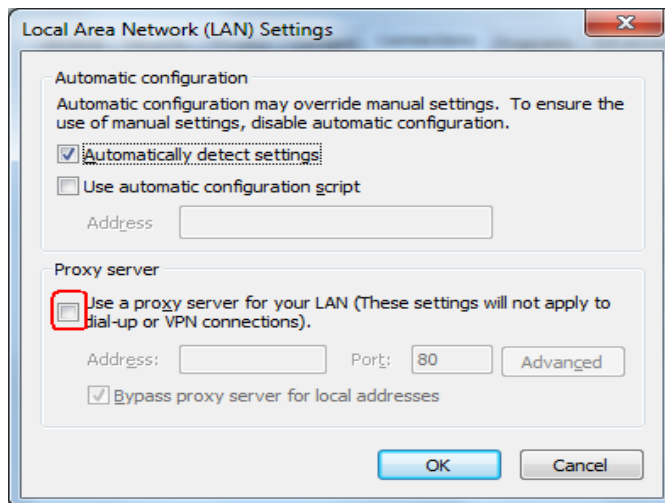

5. Click **OK**.

Step 4 Log in to the CMU WebUI.

1. In the address box of a browser, enter **https://XX.XX.XX.XX** (XX.XX.XX.XX is the IP address of the CMU) and press **Enter**. The login page is displayed.

If you log in to the WebUI for the first time, a security risk warning is displayed. Click **Continue to this website** to log in to the WebUI.

 **NOTE**

- It is recommended that users use their own certificates. If the certificate is not replaced, the security risk warning will be displayed during each login.
- After logging in to the WebUI, you can import a certificate under **Maintenance > Security Settings > Network Security Certificate**.
- The imported security certificate needs to be bound to the CMU IP address. Otherwise, the security risk warning will still be displayed during login.

Figure A-3 Security risk warning

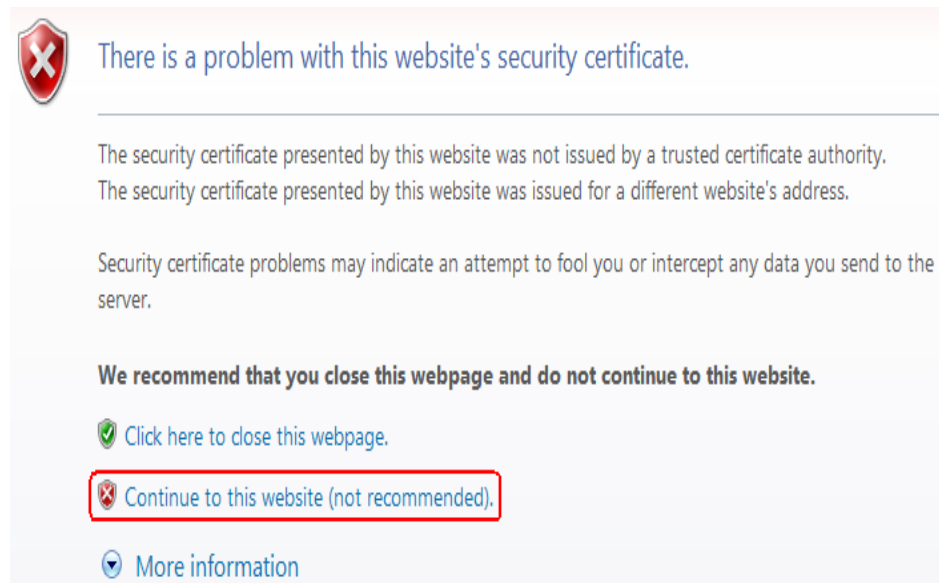

2. Specify **Language**, **User Name**, and **Password**, and click **Log In**.

Figure A-4 Login page (Initial login when the user name is displayed as **admin**)



 **NOTE**

In this scenario, you need to update the software version to V300R023C00 or later.

Parameter	Description
Language	Set this parameter as required.
User Name	Select admin .
Password	<ul style="list-style-type: none">- The initial password is Changeme1234.- Use the initial password upon first power-on and change it immediately after login. Then, use the new password to log in again.

 **NOTE**

Updating to V300R023C00 or later:

- Method 1: Enter **admin** in **User Name** and log in using your new password.
- Method 2: Select **installer** as the user name and set the login password as prompted.

Figure A-5 Login page (Initial login when the user name is empty)



IL03J00002

NOTE

In this scenario, the software version is V300R023C00 or later.

Parameter	Description
Language	Set this parameter as required.
User Name	Select installer .
Password	Set the login password as prompted.

NOTE

- To ensure account security, protect the password by changing it periodically, and keep it secure. Your password might be stolen or cracked if it is left unchanged for extended periods. If you lose the password, the device must be restored to its factory settings. In these cases, the Company shall not be liable for any loss caused to the plant.
- You will be locked out for 10 minutes after five consecutive failed password attempts in 5 minutes.
- A dialog box with recent login information is displayed after login. Click **OK**.

----End

Follow-up Procedure

If any page is blank or a menu cannot be accessed after you log in to the WebUI, clear the cache, refresh the page, or log in again.

A.2.2 Upgrading the Software Version

Prerequisites

- Before upgrade, check whether an ESU alarm is generated. If yes, clear the alarm by referring to the alarm handling suggestions and then perform the upgrade.
- Before upgrade, ensure that the SOC of the battery rack is greater than 30%. Otherwise, the delayed upgrade function may be triggered (only software is loaded without performing the upgrade).

Procedure

Step 1 Upgrade the software.

Figure A-6 Software upgrade

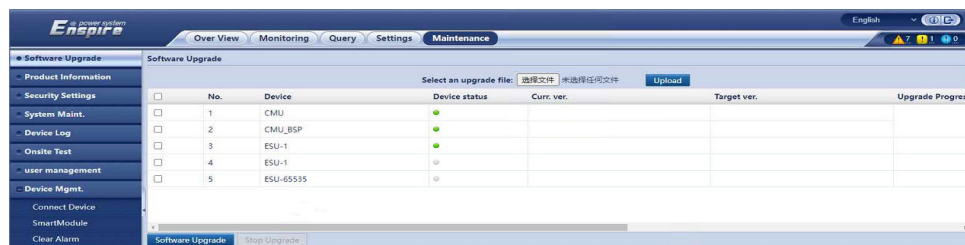

----End

NOTE

- The **Stop Upgrade** function applies only to the devices waiting to be upgraded.
- If the system displays a message indicating that the loading is successful instead of the upgrade, the delayed upgrade function is triggered. The system automatically performs the upgrade when the conditions are met.
- If the upgrade fails, contact technical support.

A.2.3 Exporting Device Logs

Step 1 Access the device log page.

Figure A-7 Exporting logs

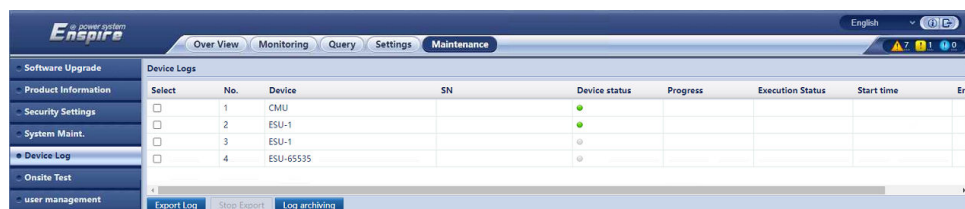

Step 2 Select the device whose logs are to be exported and click **Export Log**.

NOTE

Logs can be exported for a maximum of six devices of the same type at a time.

Step 3 Observe the progress bar and wait until the log export is complete.

Step 4 After the export is successful, click **Log archiving** to save the logs.

----End

A.2.4 Checking Alarms

Step 1 Choose **Overview > Active Alarm**.

Figure A-8 Checking alarms

Alarm ID	Severity	Device	Alarm Name	Generation time	Reason ID	Suggestion
3802	Major	CMU	Fire Alarm		1	Suggestion
3802	Major	CMU	Fire Alarm		2	Suggestion
3803	Major	CMU	Fire Extinguishing System Faulty		1	Suggestion
3801	Major	CMU	Door Status Alarm		7	Suggestion
3801	Major	CMU	Door Status Alarm		3	Suggestion
3801	Major	CMU	Door Status Alarm		2	Suggestion
3801	Major	CMU	Door Status Alarm		1	Suggestion
3853	Minor	CMU	ESU Physical Location Failure		1	Suggestion

----End

A.2.5 Clearing Alarms

You can clear all active and historical alarms for the selected device and re-collect alarm data.

Step 1 Choose **Maintenance > Device Mgmt. > Clear Alarm**.

Figure A-9 Clearing alarms

No.	Device	SN	Device status
1	CMU		●
2	ESU-1		●
3	ESU-1		●
4	ESU-65535		●

Step 2 Select the name of the device whose alarms are to be cleared, click **Submit**, and choose **All**, **Locally synchronized alarms**, or **Alarms stored on devices** to clear alarms.

----End

NOTE

If alarms are cleared on the CMU, you must reset the alarm on the SmartLogger. Otherwise, the SmartLogger cannot obtain the alarm information collected by the CMU after the alarms are cleared.

B App Operations

B.1 Downloading and Installing the App

SUN2000 app: Access Huawei AppGallery and search for **SUN2000**, or scan the following QR code (or directly visit <https://appgallery.cloud.huawei.com/appdl/C10279542>) to download and install the app.

QR code:



B.2 Logging In to the App

Prerequisites

- The CMU has been powered on.
- The WLAN function has been enabled on your phone.
- Keep the phone within 5 m of the CMU. Otherwise, the communication quality might be poor.

Procedure

Step 1 Press and hold the **RST** button for 1s to 3s to power on the CMU's built-in WLAN module.

 **NOTE**

- If the **ALM** indicator blinks green fast for 2 minutes and other indicators are off, the WLAN module is powered on.
- If the WLAN module is not connected to the app, the WLAN module is automatically powered off after being powered on for 4 hours.

Step 2 In the SUN2000 app, select a connection mode.

 **NOTE**

- The screenshots in this section correspond to the SUN2000 app 6.22.10.117 (Android).
- Use the initial password for the first login and change it immediately after login. To ensure account security, protect the password by changing it periodically, and keep it secure. Your password might be stolen or cracked if it is left unchanged for extended periods. If a password is lost, devices cannot be accessed. In these cases, the Company shall not be liable for any loss caused to the plant.

1. Tap **Manual connection** and select a product icon.

 **NOTE**

- The CMU has a built-in WLAN module. The initial name of the WLAN hotspot is **SN of the Monitor-CMU**, and the initial password is **Changeme**.
- If **Changeme** cannot be used for the first login, obtain the initial password from the QR code on the CMU.

Figure B-1 Manual connection

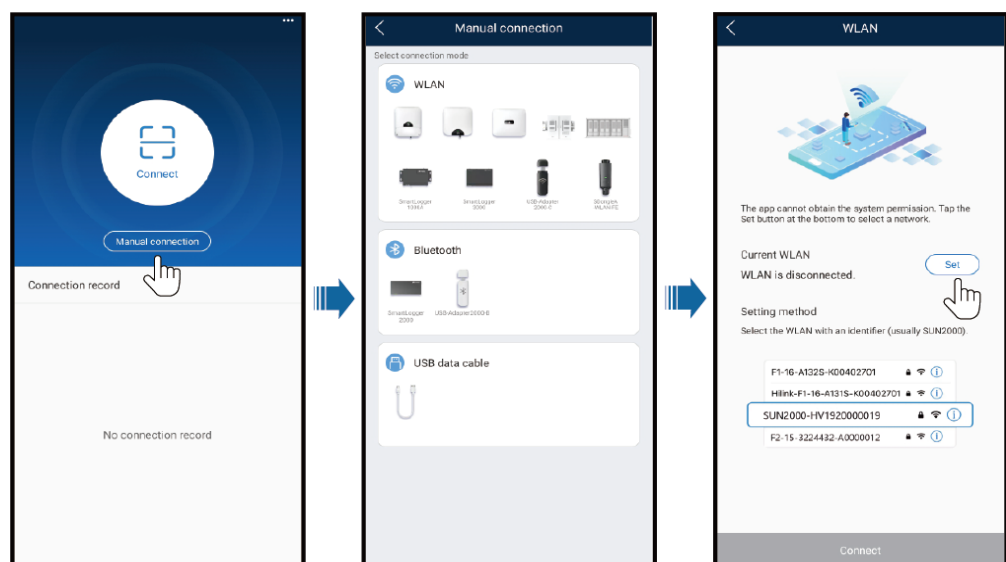

2. Tap **Connect** and scan the QR code on the CMU.

 **NOTE**

Products delivered earlier do not support connection by scanning the QR code. In this case, manually connect the product.

Step 3 Select the login user and enter the login password. The main menu screen is displayed.

NOTICE

- When you log in to the system for the first time, set the login password. To ensure account security, protect the password by changing it periodically, and keep it secure. Your password might be stolen or cracked if it is left unchanged for extended periods. If a password is lost, devices cannot be accessed. In these cases, the Company shall not be liable for any loss caused to the plant.
- For the same username, the password for logging in to the app is the same as that for logging in to the CMU WebUI.
- You will be locked out for 10 minutes after five consecutive failed password attempts in 5 minutes.

Figure B-2 Login

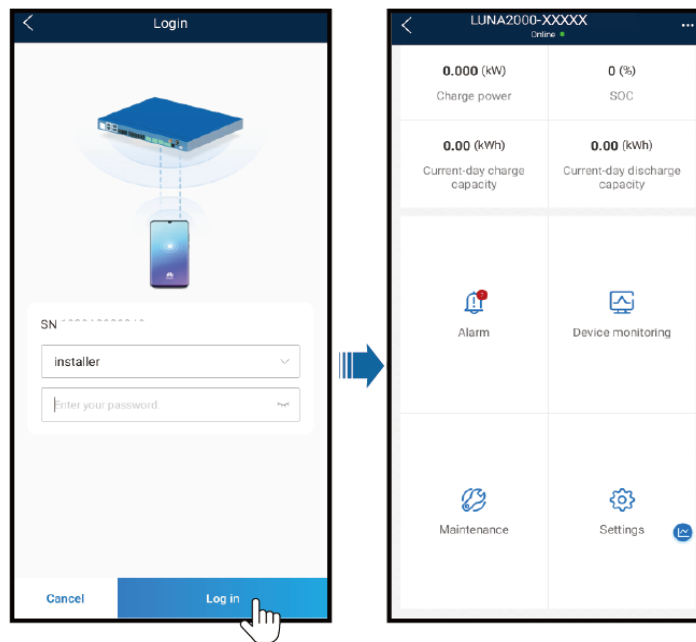

----End

B.3 Change Password

Changing the WLAN Hotspot Password of a Device

Log in to the app, choose **Settings** > **Communication settings** > **Device WLAN**, and change the WLAN hotspot password of the device.

Changing the Login Password of a User

After logging in to the app, tap  in the upper right corner of the screen, and choose **Change password** to change the login password.

C Crimping an OT or DT Terminal

Requirements on an OT or DT Terminal

- If a copper cable is used, use copper wiring terminals.
- If a copper-clad aluminum cable is used, use copper wiring terminals.
- If an aluminum alloy cable is used, use copper-to-aluminum wiring terminals, or aluminum wiring terminals along with copper-to-aluminum washers.

NOTICE

- Do not connect aluminum wiring terminals to the terminal block. Otherwise electrochemical corrosion may occur, affecting the reliability of cable connections.
 - Comply with the IEC 61238-1 requirements when using copper-to-aluminum wiring terminals, or aluminum wiring terminals along with copper-to-aluminum washers.
 - Do not mix up the aluminum and copper sides of a copper-to-aluminum washer. Ensure that the aluminum side of the washer contacts the aluminum wiring terminal, and that the copper side contacts the terminal block.
-

Figure C-1 Requirements on an OT or DT terminal

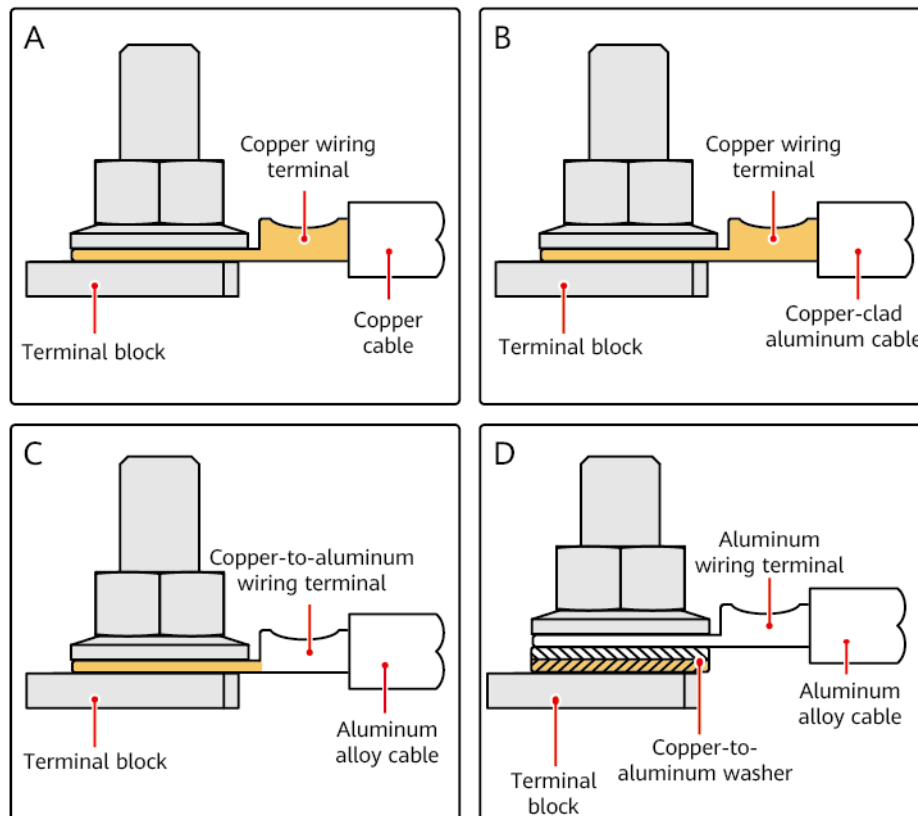

Crimping an OT or DT Terminal

NOTICE

- Avoid scratching the core wire when stripping a cable.
- The cavity formed after the conductor crimp strip of the OT or DT terminal has been crimped must wrap around the core wire completely. The core wire must make close contact with the OT or DT terminal.
- Wrap the wire crimping area with heat shrink tubing, cold shrink tubing, or insulation tape. The heat shrink tubing is used as an example.
- Use a heat gun carefully to avoid heat damage to the equipment.

Figure C-2 Crimping an OT terminal

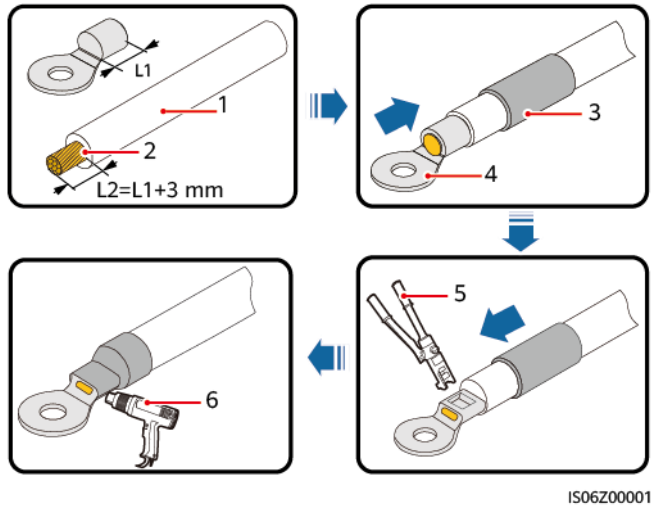

- (1) Cable
- (2) Core wire
- (3) Heat shrink tubing
- (4) OT terminal
- (5) Hydraulic pliers
- (6) Heat gun

Figure C-3 Crimping a DT terminal

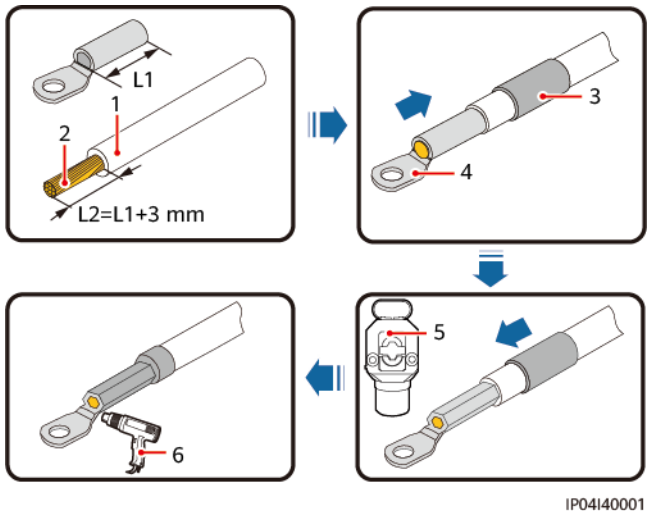

- (1) Cable
- (2) Core wire
- (3) Heat shrink tubing
- (4) DT terminal
- (5) Hydraulic pliers
- (6) Heat gun

D How Do I Repair Paint Damage?

Prerequisites

- Do not apply paint in bad weather, such as rain, snow, strong wind, and sandstorm, when there is no shelter outdoors.
- You have prepared the RAL 9003 polyurethane top coat.

Paint Repair Description

The equipment appearance shall be intact. If paint has flaked off, repair paint damage immediately.

NOTE

Check the paint damage on the equipment and prepare appropriate tools and materials. The number of materials depends on site requirements.

Table D-1 Paint repair description

Paint Damage	Tool and Material	Procedure	Description
Slight scratch (steel base material not exposed)	Spray paint or paint, brush (required for repainting a small area), fine sandpaper, anhydrous alcohol, cotton cloth, and paint spray gun (required for repainting a large area)	Steps 1, 2, 4, and 5	<ol style="list-style-type: none"> The color number of the top coat (polyurethane paint) is RAL 9003. For a few scratches, smudges, or rust, manual paint spraying or brushing is recommended.
Smudges and rust that cannot be removed			
Deep scratch (primer damaged, steel base material exposed)	Spray paint or paint, zinc-rich primer, brush (required for repainting a small area), fine sandpaper, anhydrous alcohol, cotton cloth, paint spray gun (required for repainting a large area)	Steps 1, 2, 3, 4, and 5	<ol style="list-style-type: none"> For many scratches or large-area smudges and rusts, use a paint spray gun. The paint coating shall be thin and even. Paint drops are prohibited on the coating.
Logo and pattern damage	If a logo or pattern is damaged, provide the logo size and color number. Seek help from a local supplier of advertisement coatings to formulate a repair solution based on the logo size, color, and damage.		<ol style="list-style-type: none"> Leave the repainted area for approximately 30 minutes before performing any further operation.
Dent	<ol style="list-style-type: none"> If a dent is less than or equal to 100 mm² in area and less than 3 mm in depth, fill the dent with Poly-Putty base and then perform the same operations as those for processing deep scratches. If a dent is greater than 100 mm² in area or greater than 3 mm in depth, ask the local supplier for an appropriate repainting solution. 		

Procedure

Step 1 Gently polish damaged areas using fine sandpaper to remove smudges or rust.

Figure D-1 Polishing a damaged area using sandpaper

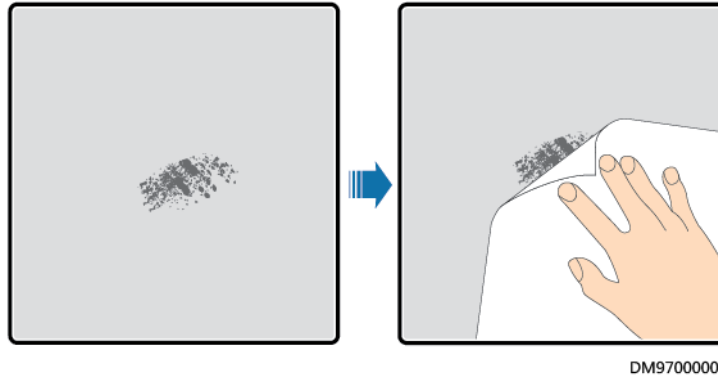

Step 2 Dip a piece of cotton cloth into anhydrous alcohol and wipe the polished or damaged area to remove the dirt and dust. Then wipe off the anhydrous alcohol with a clean and dry cotton cloth

Figure D-2 Wiping a polished or damaged area using anhydrous alcohol

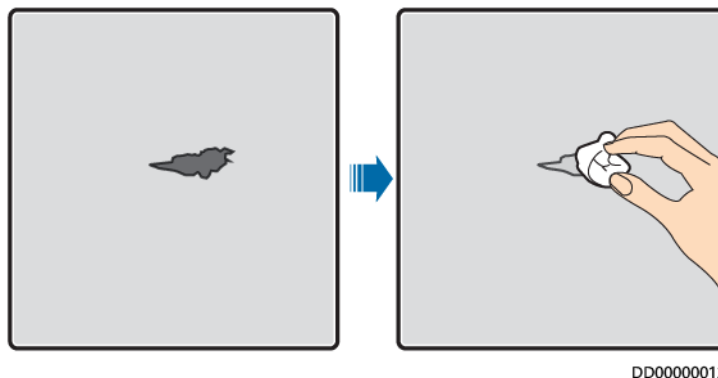

Step 3 Paint zinc-rich primer on the damaged coat using a brush or paint spray gun.

NOTICE

- If the base material is exposed in the area to be repaired, apply epoxy zinc-rich primer, wait until the paint has dried, and then apply acrylic acid top coat.
- Select epoxy zinc-rich primer or acrylic acid top coat with a color the same as the surface coating color of the equipment.

Step 4 Apply paint evenly to the damaged area based on the damage degree of the paint using an aerosol spray, brush, or paint spray gun until all damage traces are invisible.

NOTICE

- Ensure that the painting is thin, even, and smooth.
- In the case that an equipment pattern has different colors, to prevent undamaged areas and those with different colors as the damaged area from being contaminated during repainting, cover such areas using white paper and adhesive tape before repainting paint.

Figure D-3 Repainting a damaged area

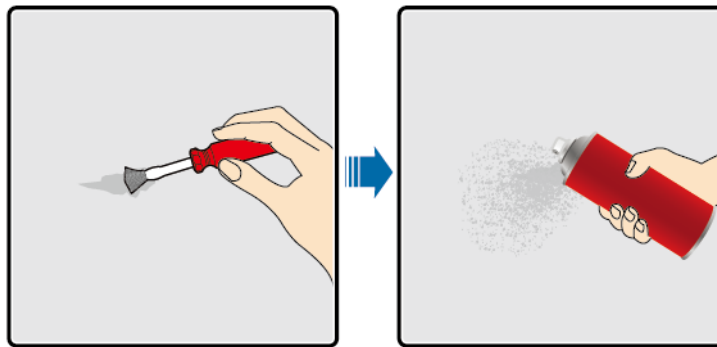

DD0000013

Step 5 Wait for 30 minutes and check whether the painting meets the requirements.

NOTE

- The color of the repainted area must be consistent with that of the surrounding area. Use a colorimeter to measure the color difference (ΔE), which shall be less than or equal to 3. If a colorimeter is unavailable, ensure that there is no visible edge between the repainted area and the surrounding area. The paint shall also be free of bulges, scratches, flaking, or cracks.
- If you choose to spray paint, it is recommended that you spray paint three times before checking the result. If the color does not meet the requirements, paint more times until the painting meets the requirements.

----End

Paint Supply Information

Table D-2 Paint requirements

Item	Requirement
Primer thickness	40 μm
Intermediate coat thickness	100 μm
Top coat thickness	40 μm
Primer type	Epoxy zinc-rich paint
Intermediate coat type	Epoxy micaceous iron oxide
Top coat type	RAL 9003 polyurethane top coat

E Certificate Management and Maintenance

Preconfigured Certificate Risk Disclaimer

The Huawei-issued certificates preconfigured on Huawei devices during manufacturing are mandatory identity credentials for Huawei devices. The disclaimer statements for using the certificates are as follows:

1. Preconfigured Huawei-issued certificates are used only in the deployment phase, for establishing initial security channels between devices and the customer's network. Huawei does not promise or guarantee the security of preconfigured certificates.
2. The customer shall bear consequences of all security risks and security incidents arising from using preconfigured Huawei-issued certificates as service certificates.
3. A preconfigured Huawei-issued certificate is valid from the manufacturing date until October 2041.
4. Services using a preconfigured Huawei-issued certificate will be interrupted when the certificate expires.
5. It is recommended that customers deploy a PKI system to issue certificates for devices and software on the live network and manage the lifecycle of the certificates. To ensure security, certificates with short validity periods are recommended.

Application Scenarios of Preconfigured Certificates

File Path and Name	Scenario	Replacement
/mnt/log/smodule_ca.crt	Authenticates the validity of the peer extension module for communication with the TLS extension module.	Certificate replacement is not supported.
/mnt/log/smodule_server.crt		

File Path and Name	Scenario	Replacement
/mnt/log/cmu_ca.crt	Authenticates the validity of the peer SACU for communication with the SACU through Modbus-TCP.	For details about how to replace a certificate, contact technical support engineers to obtain the corresponding security maintenance manual.
/mnt/log/cmu_client.crt		
/mnt/home/cert/web/server.crt	Authenticates the validity of the peer web module to be connected.	
/mnt/log/smodule_ca.crt	Authenticates the validity of the peer BCU for communication with the BCU TLS.	Certificate replacement is not supported.
/mnt/log/smodule_server.crt		
/mnt/log/tcpmb_server_cert/ca.crt	Authenticates the validity of the peer mobile app for communication through Modbus-TCP.	
/mnt/log/tcpmb_server_cert/tomcat_client.crt		

F Contact Information

If you have any questions about this product, please contact us.



<https://digitalpower.huawei.com>

Path: **About Us > Contact Us > Service Hotlines**

To ensure faster and better services, we kindly request your assistance in providing the following information:

- Model
- Serial number (SN)
- Software version
- Alarm ID or name
- Brief description of the fault symptom

 **NOTE**

EU Representative Information: Huawei Technologies Hungary Kft.
Add.: HU-1133 Budapest, Váci út 116-118., 1. Building, 6. floor.
Email: hungary.reception@huawei.com

G Acronyms and Abbreviations

B

BCU	Battery Control Unit
BMU	Battery Monitoring Unit

C

CMU	Central Monitoring Unit
------------	-------------------------

E

ESS	Smart String Energy Storage System
ETH	Ethernet
ESU	Energy Storage Unit
ESC	Smart Rack Controller
ESR	Battery Rack
ESM	Battery Pack

L

LCD	Liquid Crystal Display
------------	------------------------

P

PSU Power Supply Unit

PCS Smart PCS

S

SACU Smart Array Controller

SMU Site Monitoring Unit

STS Smart Transformer
Station

T

TCU Temperature Control Unit