

# LUNA2000-200KTL-H1 Smart Power Control System

## User Manual

**Issue** 09  
**Date** 2024-04-25



**Copyright © Huawei Technologies Co., Ltd. 2024. All rights reserved.**

No part of this document may be reproduced or transmitted in any form or by any means without prior written consent of Huawei Technologies Co., Ltd.

## **Trademarks and Permissions**



HUAWEI and other Huawei trademarks are trademarks of Huawei Technologies Co., Ltd.

All other trademarks and trade names mentioned in this document are the property of their respective holders.

## **Notice**

The purchased products, services and features are stipulated by the contract made between Huawei and the customer. All or part of the products, services and features described in this document may not be within the purchase scope or the usage scope. Unless otherwise specified in the contract, all statements, information, and recommendations in this document are provided "AS IS" without warranties, guarantees or representations of any kind, either express or implied.

The information in this document is subject to change without notice. Every effort has been made in the preparation of this document to ensure accuracy of the contents, but all statements, information, and recommendations in this document do not constitute a warranty of any kind, express or implied.

## **Huawei Technologies Co., Ltd.**

Address: Huawei Industrial Base  
Bantian, Longgang  
Shenzhen 518129  
People's Republic of China

Website: <https://e.huawei.com>

# About This Document

## Purpose

This document describes the installation, electrical connections, commissioning, maintenance, and troubleshooting of LUNA2000-200KTL-H1 Smart Power Control System (also referred to as Smart PCS). Before installing and operating the Smart PCS, ensure that you are familiar with the features, functions, and safety precautions provided in this document.





## Intended Audience

This document is intended for:

- Installers
- Users

## Symbol Conventions

The symbols that may be found in this document are defined as follows:

Symbol	Description
 <b>DANGER</b>	Indicates a hazard with a high level of risk which, if not avoided, will result in death or serious injury.
 <b>WARNING</b>	Indicates a hazard with a medium level of risk which, if not avoided, could result in death or serious injury.
 <b>CAUTION</b>	Indicates a hazard with a low level of risk which, if not avoided, could result in minor or moderate injury.
 <b>NOTICE</b>	Indicates a potentially hazardous situation which, if not avoided, could result in equipment damage, data loss, performance deterioration, or unanticipated results. NOTICE is used to address practices not related to personal injury.

Symbol	Description
 NOTE	Supplements the important information in the main text. NOTE is used to address information not related to personal injury, equipment damage, and environment deterioration.

## Change History

Changes between document issues are cumulative. The latest document issue contains all the changes made in earlier issues.

### Issue 09 (2024-04-25)

Updated [B Grid Codes](#).

Updated [7 Power-On and Commissioning](#).

### Issue 08 (2024-01-23)

Updated [1.3 Environment Requirements](#).

Updated [2.1 Model](#).

Updated [2.6 Label Description](#).

Updated [3 Storage Requirements](#).

Updated [4.2.1 Site Selection Requirements](#).

Updated [5.8.1 Connecting FE Communications Cables](#).

### Issue 07 (2023-10-16)

Updated [5.8.1 Connecting FE Communications Cables](#).

### Issue 06 (2023-09-30)

Updated [2 Product Description](#).

Updated [2.2 Networking Application](#).

Updated [4.2.1 Site Selection Requirements](#).

Updated [B Grid Codes](#).

### Issue 05 (2023-07-30)

Updated [2.2 Networking Application](#).

Updated [5.2 Preparing Cables](#).

Deleted the content related to CAN communication.

## Issue 04 (2023-06-30)

Updated [2.2 Networking Application](#) .

Updated [4.5 Moving the Smart PCS](#).

Updated [9 Technical Specifications](#).

Adjusted the document structure.

## Issue 03 (2023-05-10)

Updated [5.8.1 Connecting FE Communications Cables](#).

## Issue 02 (2023-01-10)

Updated [1 Safety Information](#).

Updated [4.4 Pre-installation Check](#).

Updated [5.1 Precautions](#).

Updated [5.7 Connecting AC Power Cables](#).

Updated [5.8.1 Connecting FE Communications Cables](#).

Updated [7.1 Powering on the Smart PCS](#).

Updated [8 Device Maintenance](#).

Updated [8.5 Replacing the Smart PCS](#).

Added [C Resetting Password](#).

## Issue 01 (2022-08-31)

This issue is used for first office application (FOA).

---

# Contents

---

<b>About This Document.....</b>	<b>ii</b>
<b>1 Safety Information.....</b>	<b>1</b>
1.1 Personal Safety.....	2
1.2 Electrical Safety.....	4
1.3 Environment Requirements.....	6
1.4 Mechanical Safety.....	8
<b>2 Product Description.....</b>	<b>13</b>
2.1 Model.....	14
2.2 Networking Application .....	15
2.3 Appearance.....	19
2.4 Circuit Diagram.....	22
2.5 Working Modes.....	22
2.6 Label Description.....	24
<b>3 Storage Requirements.....</b>	<b>26</b>
<b>4 Installation.....</b>	<b>27</b>
4.1 Installation Modes.....	27
4.2 Installation Requirements.....	27
4.2.1 Site Selection Requirements.....	27
4.2.2 Mounting Structure Requirements.....	29
4.2.3 Clearance Requirements.....	30
4.2.4 Angle Requirements.....	32
4.3 Preparing Tools.....	32
4.4 Pre-installation Check.....	34
4.5 Moving the Smart PCS.....	35
4.6 Support Mounting.....	37
4.7 Wall Mounting.....	39
4.8 DCBOX Mounting.....	42
<b>5 Cable Connection.....</b>	<b>44</b>
5.1 Precautions.....	44
5.2 Preparing Cables.....	45
5.3 Connecting a PE Cable.....	46

5.4 Opening the Maintenance Compartment Door.....	47
5.4.1 Opening the DC Maintenance Compartment Door.....	47
5.4.2 Opening the AC Maintenance Compartment Door.....	48
5.5 (Optional) Replacing Crimping Modules.....	49
5.6 Connecting DC Power Cables.....	50
5.7 Connecting AC Power Cables.....	53
5.8 Connecting Communications Cables.....	55
5.8.1 Connecting FE Communications Cables.....	56
5.9 Closing the Maintenance Compartment Door.....	59
5.9.1 Closing the DC Maintenance Compartment Door.....	59
5.9.2 Closing the AC Maintenance Compartment Door.....	60
<b>6 Checking Before Power-On.....</b>	<b>61</b>
<b>7 Power-On and Commissioning.....</b>	<b>63</b>
7.1 Powering on the Smart PCS.....	63
7.1.1 On-Grid Power-On.....	64
7.1.2 Off-Grid Power-On.....	64
7.1.3 Commissioning the Smart PCS Using the App.....	65
7.1.3.1 Downloading the App.....	65
7.1.3.2 Logging In to the App.....	66
<b>8 Device Maintenance.....</b>	<b>69</b>
8.1 Routine Maintenance.....	69
8.2 Powering Off the System.....	71
8.3 Alarm Reference.....	72
8.4 Replacing a Fan.....	73
8.5 Replacing the Smart PCS.....	77
8.6 Disposing of the Smart PCS.....	83
<b>9 Technical Specifications.....</b>	<b>84</b>
<b>A Crimping an OT or DT Terminal.....</b>	<b>87</b>
<b>B Grid Codes.....</b>	<b>90</b>
<b>C Resetting Password.....</b>	<b>93</b>
<b>D Certificate Management and Maintenance.....</b>	<b>94</b>
<b>E Contact Information.....</b>	<b>95</b>
<b>F Digital Power Customer Service.....</b>	<b>97</b>
<b>G Acronyms and Abbreviations.....</b>	<b>98</b>

# 1 Safety Information

---

## Statement

**Before transporting, storing, installing, operating, using, and/or maintaining the equipment, read this document, strictly follow the instructions provided herein, and follow all the safety instructions on the equipment and in this document.** In this document, "equipment" refers to the products, software, components, spare parts, and/or services related to this document; "the Company" refers to the manufacturer (producer), seller, and/or service provider of the equipment; "you" refers to the entity that transports, stores, installs, operates, uses, and/or maintains the equipment.

The **Danger, Warning, Caution, and Notice** statements described in this document do not cover all the safety precautions. You also need to comply with relevant international, national, or regional standards and industry practices. **The Company shall not be liable for any consequences that may arise due to violations of safety requirements or safety standards concerning the design, production, and usage of the equipment.**

The equipment shall be used in an environment that meets the design specifications. Otherwise, the equipment may be faulty, malfunctioning, or damaged, which is not covered under the warranty. The Company shall not be liable for any property loss, personal injury, or even death caused thereby.

Comply with applicable laws, regulations, standards, and specifications during transportation, storage, installation, operation, use, and maintenance.

Do not perform reverse engineering, decompilation, disassembly, adaptation, implantation, or other derivative operations on the equipment software. Do not study the internal implementation logic of the equipment, obtain the source code of the equipment software, violate intellectual property rights, or disclose any of the performance test results of the equipment software.

**The Company shall not be liable for any of the following circumstances or their consequences:**

- The equipment is damaged due to force majeure such as earthquakes, floods, volcanic eruptions, debris flows, lightning strikes, fires, wars, armed conflicts, typhoons, hurricanes, tornadoes, and other extreme weather conditions.
- The equipment is operated beyond the conditions specified in this document.

- The equipment is installed or used in environments that do not comply with international, national, or regional standards.
- The equipment is installed or used by unqualified personnel.
- You fail to follow the operation instructions and safety precautions on the product and in the document.
- You remove or modify the product or modify the software code without authorization.
- You or a third party authorized by you cause the equipment damage during transportation.
- The equipment is damaged due to storage conditions that do not meet the requirements specified in the product document.
- You fail to prepare materials and tools that comply with local laws, regulations, and related standards.
- The equipment is damaged due to your or a third party's negligence, intentional breach, gross negligence, or improper operations, or other reasons not related to the Company.

## 1.1 Personal Safety

---

 **DANGER**

Ensure that power is off during installation. Do not install or remove a cable with power on. Transient contact between the core of the cable and the conductor will generate electric arcs or sparks, which may cause a fire or personal injury.

---

---

 **DANGER**

Non-standard and improper operations on the energized equipment may cause fire, electric shocks, or explosion, resulting in property damage, personal injury, or even death.

---

---

 **DANGER**

Before operations, remove conductive objects such as watches, bracelets, bangles, rings, and necklaces to prevent electric shocks.

---

---

 **DANGER**

During operations, use dedicated insulated tools to prevent electric shocks or short circuits. The dielectric withstanding voltage level must comply with local laws, regulations, standards, and specifications.

---

**WARNING**

During operations, wear personal protective equipment such as protective clothing, insulated shoes, goggles, safety helmets, and insulated gloves.

**Figure 1-1** Personal protective equipment

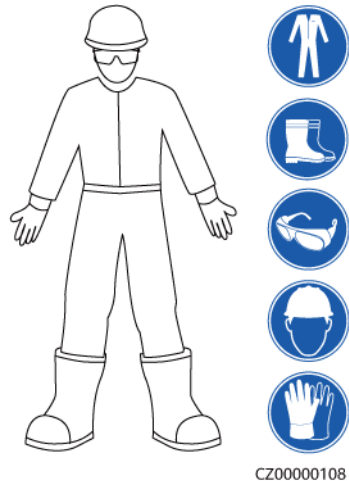

## General Requirements

- Do not stop protective devices. Pay attention to the warnings, cautions, and related precautionary measures in this document and on the equipment.
- If there is a likelihood of personal injury or equipment damage during operations, immediately stop, report the case to the supervisor, and take feasible protective measures.
- Do not power on the equipment before it is installed or confirmed by professionals.
- Do not touch the power supply equipment directly or with conductors such as damp objects. Before touching any conductor surface or terminal, measure the voltage at the contact point to ensure that there is no risk of electric shock.
- Do not touch operating equipment because the enclosure is hot.
- Do not touch a running fan with your hands, components, screws, tools, or boards. Otherwise, personal injury or equipment damage may occur.
- In the case of a fire, immediately leave the building or the equipment area and activate the fire alarm or call emergency services. Do not enter the affected building or equipment area under any circumstances.

## Personnel Requirements

- Only professionals and trained personnel are allowed to operate the equipment.
  - Professionals: personnel who are familiar with the working principles and structure of the equipment, trained or experienced in equipment operations and are clear of the sources and degree of various potential hazards in equipment installation, operation, maintenance

- Trained personnel: personnel who are trained in technology and safety, have required experience, are aware of possible hazards on themselves in certain operations, and are able to take protective measures to minimize the hazards on themselves and other people
- Personnel who plan to install or maintain the equipment must receive adequate training, be able to correctly perform all operations, and understand all necessary safety precautions and local relevant standards.
- Only qualified professionals or trained personnel are allowed to install, operate, and maintain the equipment.
- Only qualified professionals are allowed to remove safety facilities and inspect the equipment.
- Personnel who will perform special tasks such as electrical operations, working at heights, and operations of special equipment must possess the required local qualifications.
- Only authorized professionals are allowed to replace the equipment or components (including software).
- Only personnel who need to work on the equipment are allowed to access the equipment.

## 1.2 Electrical Safety

---

 **DANGER**

Before connecting cables, ensure that the equipment is intact. Otherwise, electric shocks or fire may occur.

---

---

 **DANGER**

Non-standard and improper operations may result in fire or electric shocks.

---

---

 **DANGER**

Prevent foreign matter from entering the equipment during operations. Otherwise, equipment short-circuits or damage, load power derating, power failure, or personal injury may occur.

---

---

 **WARNING**

For the equipment that needs to be grounded, install the ground cable first when installing the equipment and remove the ground cable last when removing the equipment.

---

 **CAUTION**

Do not route cables near the air intake or exhaust vents of the equipment.

## General Requirements

- Follow the procedures described in the document for installation, operation, and maintenance. Do not reconstruct or alter the equipment, add components, or change the installation sequence without permission.
- Obtain approval from the national or local electric utility company before connecting the equipment to the grid.
- Observe the power plant safety regulations, such as the operation and work ticket mechanisms.
- Install temporary fences or warning ropes and hang "No Entry" signs around the operation area to keep unauthorized personnel away from the area.
- Before installing or removing power cables, turn off the switches of the equipment and its upstream and downstream switches.
- Before performing operations on the equipment, check that all tools meet the requirements and record the tools. After the operations are complete, collect all of the tools to prevent them from being left inside the equipment.
- Before installing power cables, check that cable labels are correct and cable terminals are insulated.
- When installing the equipment, use a torque tool of a proper measurement range to tighten the screws. When using a wrench to tighten the screws, ensure that the wrench does not tilt and the torque error does not exceed 10% of the specified value.
- Ensure that bolts are tightened with a torque tool and marked in red and blue after double-check. Installation personnel mark tightened bolts in blue. Quality inspection personnel confirm that the bolts are tightened and then mark them in red. (The marks must cross the edges of the bolts.)

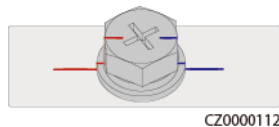

- If the equipment has multiple inputs, disconnect all the inputs before operating the equipment.
- Before maintaining a downstream electrical or power distribution device, turn off the output switch on the power supply equipment.
- During equipment maintenance, attach "Do not switch on" labels near the upstream and downstream switches or circuit breakers as well as warning signs to prevent accidental connection. The equipment can be powered on only after troubleshooting is complete.
- Do not open equipment panels.
- Check equipment connections periodically, ensuring that all screws are securely tightened.
- Only qualified professionals can replace a damaged cable.
- Do not scrawl, damage, or block any labels or nameplates on the equipment. Promptly replace labels that have worn out.

- Do not use solvents such as water, alcohol, or oil to clean electrical components inside or outside of the equipment.

## Grounding

- Ensure that the grounding impedance of the equipment complies with local electrical standards.
- Ensure that the equipment is connected permanently to the protective ground. Before operating the equipment, check its electrical connection to ensure that it is reliably grounded.
- Do not work on the equipment in the absence of a properly installed ground conductor.
- Do not damage the ground conductor.

## Cabling Requirements

- When selecting, installing, and routing cables, follow local safety regulations and rules.
- When routing power cables, ensure that there is no coiling or twisting. Do not join or weld power cables. If necessary, use a longer cable.
- Ensure that all cables are properly connected and insulated, and meet specifications.
- Ensure that the slots and holes for routing cables are free from sharp edges, and that the positions where cables are routed through pipes or cable holes are equipped with cushion materials to prevent the cables from being damaged by sharp edges or burrs.
- Ensure that cables of the same type are bound together neatly and straight and that the cable sheath is intact. When routing cables of different types, ensure that they are away from each other without entanglement and overlapping.
- Secure buried cables using cable supports and cable clips. Ensure that the cables in the backfill area are in close contact with the ground to prevent cable deformation or damage during backfilling.
- If the external conditions (such as the cable layout or ambient temperature) change, verify the cable usage in accordance with the IEC-60364-5-52 or local laws and regulations. For example, check that the current-carrying capacity meets requirements.
- When routing cables, reserve at least 30 mm clearance between the cables and heat-generating components or areas. This prevents deterioration or damage to the cable insulation layer.

## 1.3 Environment Requirements

---

 **DANGER**

Do not expose the equipment to flammable or explosive gas or smoke. Do not perform any operation on the equipment in such environments.

---

---

 **DANGER**

Do not store any flammable or explosive materials in the equipment area.

---

---

 **DANGER**

Do not place the equipment near heat sources or fire sources, such as smoke, candles, heaters, or other heating devices. Overheat may damage the equipment or cause a fire.

---

---

 **WARNING**

Install the equipment in an area far away from liquids. Do not install it under areas prone to condensation, such as under water pipes and air exhaust vents, or areas prone to water leakage, such as air conditioner vents, ventilation vents, or feeder windows of the equipment room. Ensure that no liquid enters the equipment to prevent faults or short circuits.

---

---

 **WARNING**

To prevent damage or fire due to high temperature, ensure that the ventilation vents or heat dissipation systems are not obstructed or covered by other objects while the equipment is running.

---

## General Requirements

- Store the equipment according to the storage requirements. Equipment damage caused by unqualified storage conditions is not covered under the warranty.
- Keep the installation and operating environments of the equipment within the allowed ranges. Otherwise, its performance and safety will be compromised.
- The operating temperature range provided in the equipment's technical specifications refers to the ambient temperatures in equipment's installation environment.
- Do not install, use, or operate outdoor equipment and cables (including but not limited to moving equipment, operating equipment and cables, inserting connectors to or removing connectors from signal ports connected to outdoor facilities, working at heights, performing outdoor installation, and opening doors) in harsh weather conditions such as lightning, rain, snow, and level 6 or stronger wind.
- Do not install the equipment in an environment with dust, smoke, volatile or corrosive gases, infrared and other radiations, organic solvents, or salty air.
- Do not install the equipment in an environment with conductive metal or magnetic dust.
- Do not install the equipment in an area conducive to the growth of microorganisms such as fungus or mildew.

- Do not install the equipment in an area with strong vibration, noise, or electromagnetic interference. The equipment shall be installed in an environment with a magnetic field strength less than 4 Gauss. If the magnetic field strength is greater than or equal to 4 Gauss, the equipment may fail to work properly. If the magnetic field strength is high, for example, in a smeltery, you are advised to use a gauss meter to measure the magnetic field strength of the equipment installation position when the smelting equipment is running normally.
- Ensure that the site complies with local laws, regulations, and related standards.
- Ensure that the ground in the installation environment is solid, free from spongy or soft soil, and not prone to subsidence. The site must not be located in a low-lying land prone to water or snow accumulation, and the horizontal level of the site must be above the highest water level of that area in history.
- Do not install the equipment in a position that may be submerged in water.
- Do not install the equipment outdoors in salt-affected areas because it may be corroded. A salt-affected area refers to the region within 500 m of the coast or prone to sea breeze. Regions prone to sea breeze vary with weather conditions (such as typhoons and monsoons) or terrains (such as dams and hills).
- Before opening doors during the installation, operation, and maintenance of the equipment, clean up any water, ice, snow, or other foreign objects on the top of the equipment to prevent foreign objects from falling into the equipment.
- When installing the equipment, ensure that the installation surface is solid enough to bear the weight of the equipment.
- After installing the equipment, remove the packing materials such as cartons, foam, plastics, and cable ties from the equipment area.

## 1.4 Mechanical Safety

---

 **WARNING**

Ensure that all necessary tools are ready and inspected by a professional organization. Do not use tools that have signs of scratches or fail to pass the inspection or whose inspection validity period has expired. Ensure that the tools are secure and not overloaded.

---

---

 **WARNING**

Do not drill holes into the equipment. Doing so may affect the sealing performance and electromagnetic containment of the equipment and damage components or cables inside. Metal shavings from drilling may short-circuit boards inside the equipment.

---

## General Requirements

- Repaint any paint scratches caused during equipment transportation or installation in a timely manner. Equipment with scratches must not be exposed for an extended period of time.
- Do not perform operations such as arc welding and cutting on the equipment without evaluation by the Company.
- Do not install other devices on the top of the equipment without evaluation by the Company.
- When performing operations over the top of the equipment, take measures to protect the equipment against damage.
- Use correct tools and operate them in the correct way.

## Moving Heavy Objects

- Be cautious to prevent injury when moving heavy objects.

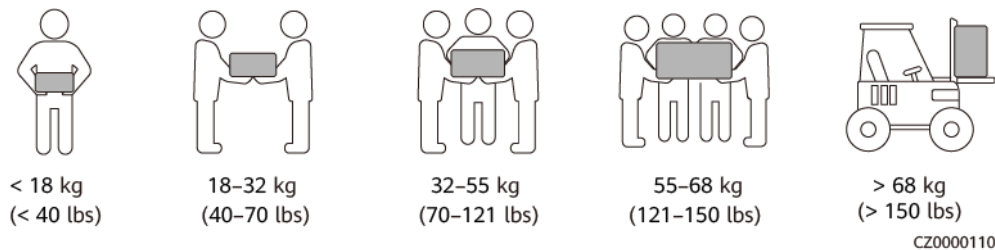

- If multiple persons need to move a heavy object together, determine the manpower and work division with consideration of height and other conditions to ensure that the weight is equally distributed.
- If two persons or more move a heavy object together, ensure that the object is lifted and landed simultaneously and moved at a uniform pace under the supervision of one person.
- Wear personal protective gears such as protective gloves and shoes when manually moving the equipment.
- To move an object by hand, approach to the object, squat down, and then lift the object gently and stably by the force of the legs instead of your back. Do not lift it suddenly or turn your body around.
- Do not quickly lift a heavy object above your waist. Place the object on a workbench that is half-waist high or any other appropriate place, adjust the positions of your palms, and then lift it.
- Move a heavy object stably with balanced force at an even and low speed. Put down the object stably and slowly to prevent any collision or drop from scratching the surface of the equipment or damaging the components and cables.
- When moving a heavy object, be aware of the workbench, slope, staircase, and slippery places. When moving a heavy object through a door, ensure that the door is wide enough to move the object and avoid bumping or injury.
- When transferring a heavy object, move your feet instead of turning your waist around. When lifting and transferring a heavy object, ensure that your feet point to the target direction of movement.
- When transporting the equipment using a pallet truck or forklift, ensure that the tynes are properly positioned so that the equipment does not topple.

Before moving the equipment, secure it to the pallet truck or forklift using ropes. When moving the equipment, assign dedicated personnel to take care of it.

- Choose sea, roads in good conditions, or airplanes for transportation. Do not transport the equipment by railway. Avoid tilt or jolt during transportation.

## Using Ladders

- Use wooden or insulated ladders when you need to perform live-line working at heights.
- Platform ladders with protective rails are preferred. Single ladders are not recommended.
- Before using a ladder, check that it is intact and confirm its load bearing capacity. Do not overload it.
- Ensure that the ladder is securely positioned and held firm.



CZ00000107

- When climbing up the ladder, keep your body stable and your center of gravity between the side rails, and do not overreach to the sides.
- When a step ladder is used, ensure that the pull ropes are secured.
- If a single ladder is used, the recommended angle for the ladder against the floor is 75 degrees, as shown in the following figure. A square can be used to measure the angle.

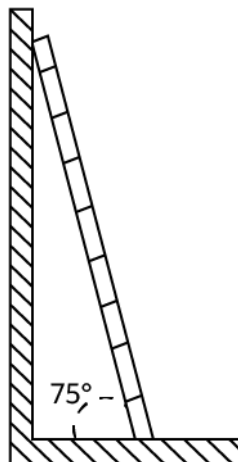

PI02SC0008

- If a single ladder is used, ensure that the wider end of the ladder is at the bottom, and take protective measures to prevent the ladder from sliding.

- If a single ladder is used, do not climb higher than the fourth rung from the top of the ladder.
- If you use a single ladder to climb up to a platform, ensure that the ladder is at least 1 m higher than the platform.

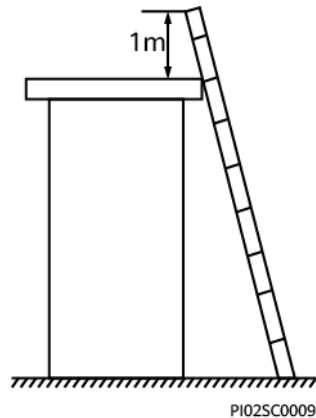

## Hoisting

- Only trained and qualified personnel are allowed to perform hoisting operations.
- Install temporary warning signs or fences to isolate the hoisting area.
- Ensure that the foundation where hoisting is performed on meets the load-bearing requirements.
- Before hoisting objects, ensure that hoisting tools are firmly secured onto a fixed object or wall that meets the load-bearing requirements.
- During hoisting, do not stand or walk under the crane or the hoisted objects.
- Do not drag steel ropes and hoisting tools or bump the hoisted objects against hard objects during hoisting.
- Ensure that the angle between two hoisting ropes is no more than 90 degrees, as shown in the following figure.

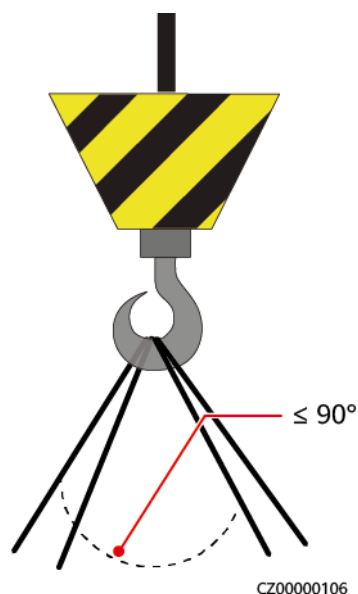

## Drilling Holes

- Obtain consent from the customer and contractor before drilling holes.
- Wear protective equipment such as safety goggles and protective gloves when drilling holes.
- To avoid short circuits or other risks, do not drill holes into buried pipes or cables.
- When drilling holes, protect the equipment from shavings. After drilling, clean up any shavings.

# 2 Product Description

---

## On-grid:

- The Smart PCS implements rectification and inversion through a three-phase three-level converter.
- The rectified output is converted from three-phase AC power to DC power and then stored in the energy storage system (ESS).
- The inverted output is filtered to three-phase AC power, which is then isolated and boosted by a three-phase transformer and fed into the power grid.

## Off-grid:

- When the Smart PCS is off-grid, it can also implement rectification and inversion through a three-phase three-level converter.
- The rectified output is converted from three-phase AC power to DC power and then stored in the ESS.
- The inverted output is converted from DC power to three-phase AC power, which is then isolated and converted by a transformer and supplied to loads.

For details about on-grid scenarios, see [On-Grid Utility-Scale Energy Storage Solution Quick Guide](#). For details about microgrid scenarios, see [Medium-Voltage Microgrid Energy Storage Solution Quick Guide](#).

## 2.1 Model

### Model Description

Figure 2-1 Model

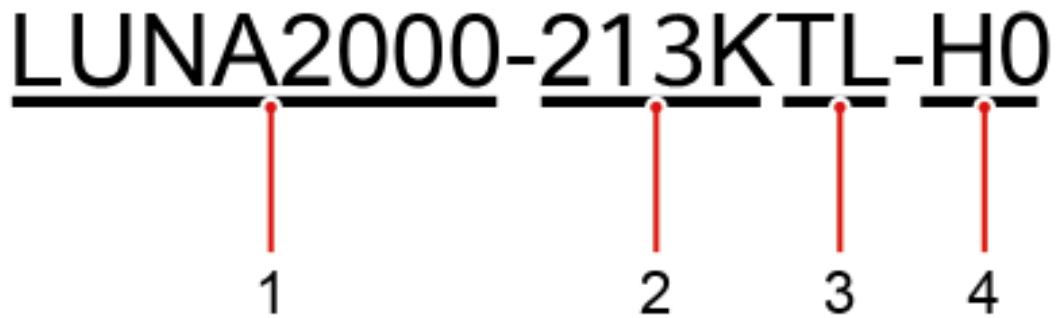

Table 2-1 Model description

No.	Meaning	Description
1	Product family identifier	LUNA2000: Smart PCS
2	Power level identifier	200K: The power level is 200 kW.
3	Topology identifier	TL: transformerless
4	Product series identifier	H1: product series with the 1500 V DC voltage

### Model Label Positions

You can obtain the device model from the model label on the outer packaging and the nameplate on the side of the enclosure.

**Figure 2-2** Position of the model label on the outer packaging

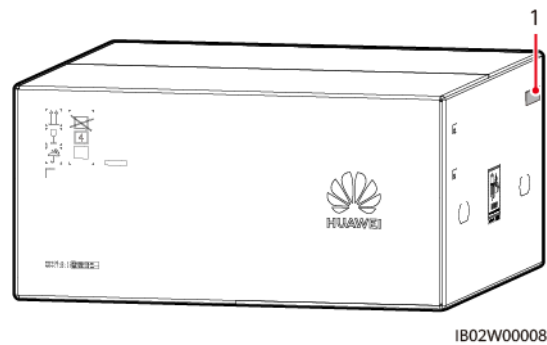

(1) Position of the model label

**Figure 2-3** Position of the nameplate

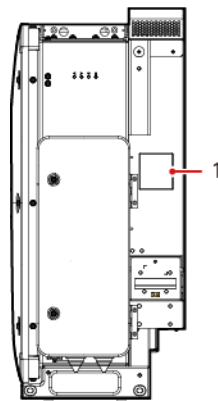

(1) Position of the nameplate

## 2.2 Networking Application

The system consists of the ESS (including the Smart Rack Controller), Smart Power Control System (PCS), Smart Transformer Station (STS), Distribution Transformer (DTS), and other equipment.

**Figure 2-4** Networking application (on-grid scenario)

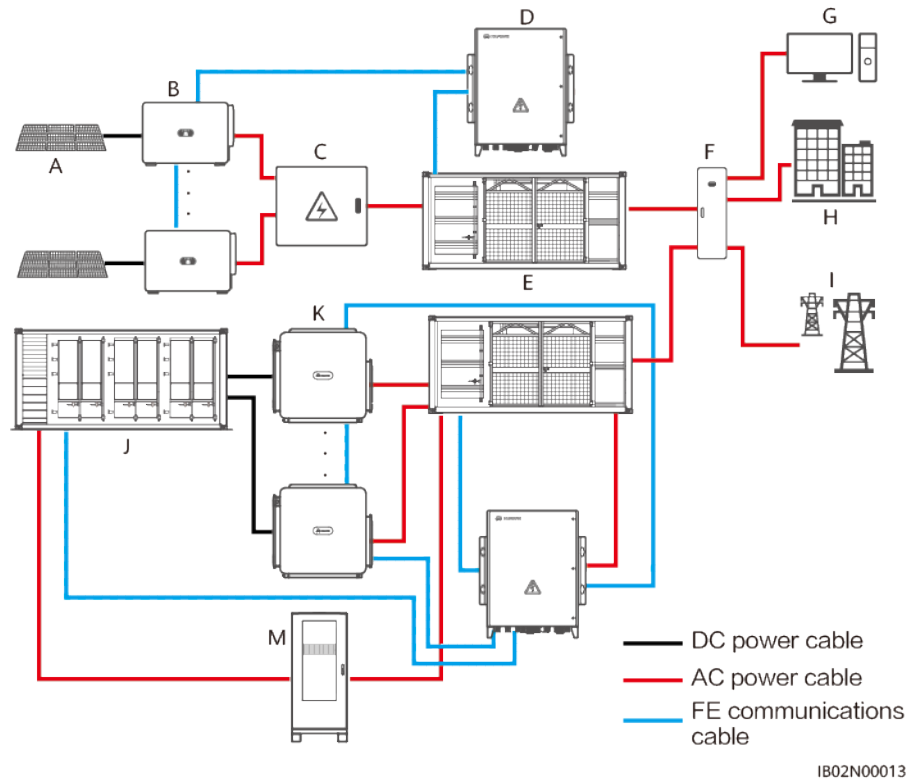

**Figure 2-5** Networking application (off-grid scenario)

**NOTE**

By default, the Smart PCS supports on-grid mode. If off-grid functions are required, purchase the off-grid license and load the license by referring to [License Management](#) in the *SmartLogger3000 User Manual*. Otherwise, off-grid functions cannot be used.

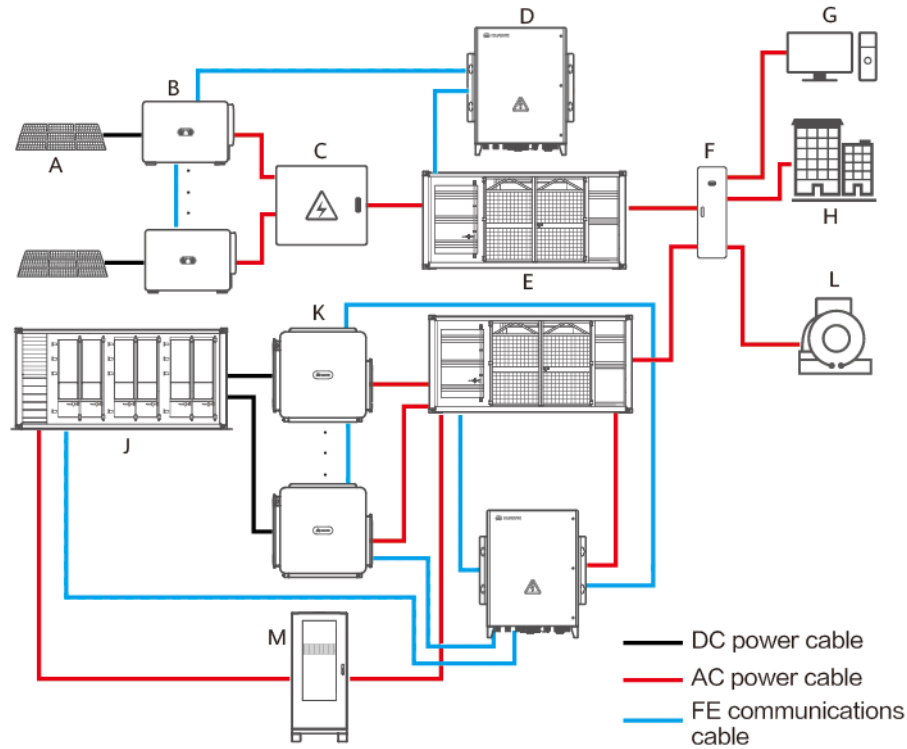

(A) PV array	(B) Inverter	(C) Combiner box
(D) Smart Array Controller (SACU)	(E) STS	(F) Medium-voltage power distribution cabinet
(G) Critical load	(H) Common load	(I) Power grid
(J) ESS	(K) Smart PCS	(L) Diesel generator system
(M) DTS	-	-

**NOTE**

The grid forming function is supported only by the Smart PCS with the BOM code 01076613. For details about how to set grid forming parameters, see the following table.

Parameter	Value (Grid Forming Scenario)	Value (Non-Grid Forming Scenario)
<b>Scenario under Arrays Operation Scenario</b>	On-grid	
<b>Working mode under Parameter Configuration</b>	VSG	PQ

Parameter	Value (Grid Forming Scenario)	Value (Non-Grid Forming Scenario)
<b>Microgrid compatibility</b> under <b>Parameter Configuration</b>	Disable	
<b>Active Power Baseline (kW)</b> under <b>Parameter Configuration</b>	83.33	200
<b>Apparent Power Baseline (kVA)</b> under <b>Parameter Configuration</b>	83.33	200
<b>Maximum Overload Active Power (kW)</b> under <b>Parameter Configuration</b>	105	240
<b>Maximum Overload Apparent Power (kVA)</b> under <b>Parameter Configuration</b>	250	240
Grid Code	Set this parameter based on the grid code of the country or region where the devices are used.	

## Earthing System

The Smart PCS supports the IT earthing system.

**Figure 2-6** Earthing system

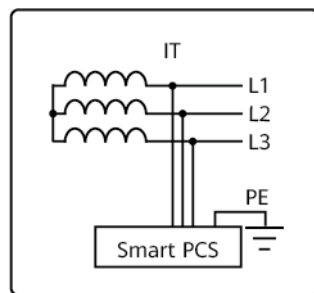

IB02P00004

## 2.3 Appearance

### Appearance and Ports

Figure 2-7 Appearance and ports

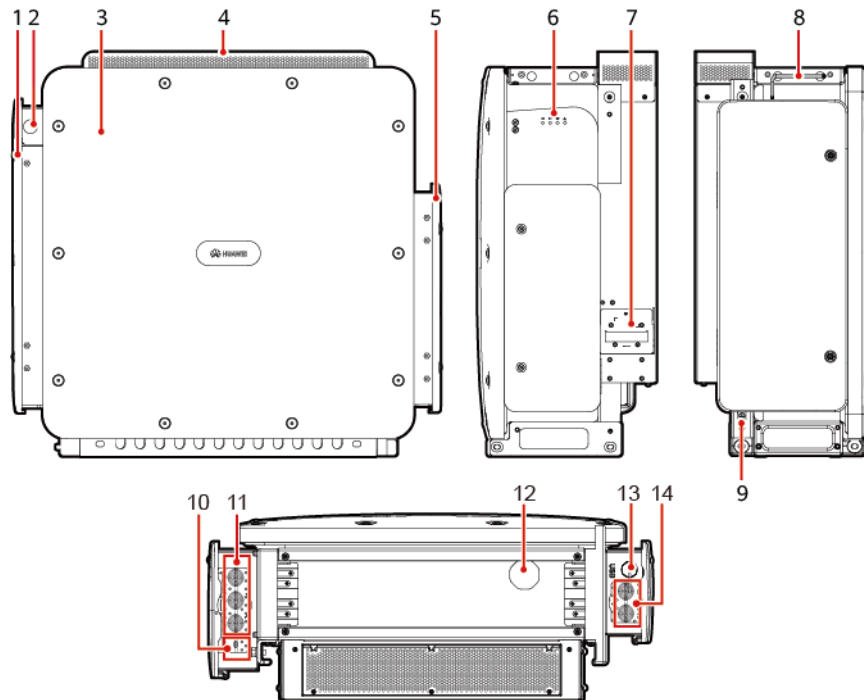

IB02W00001

(1) AC maintenance compartment

(2) Communications cable hole (FE)

(3) Panel

(4) Protective cover

(5) DC maintenance compartment

(6) LED indicators

(7) External fan tray

(8) Security Torx wrench<sup>[1]</sup>

(9) Protective earthing point

(10) Communications cable hole (COM)

(11) AC power cable holes

(12) Ventilation valve holes

(13) USB port (USB)

(14) DC power cable holes

-

Note [1]: The security Torx wrench is delivered with the device and is tied to the bracket on the top of the device. Remove the security Torx wrench from the bracket and keep it safe.

## Dimensions

Figure 2-8 Dimensions

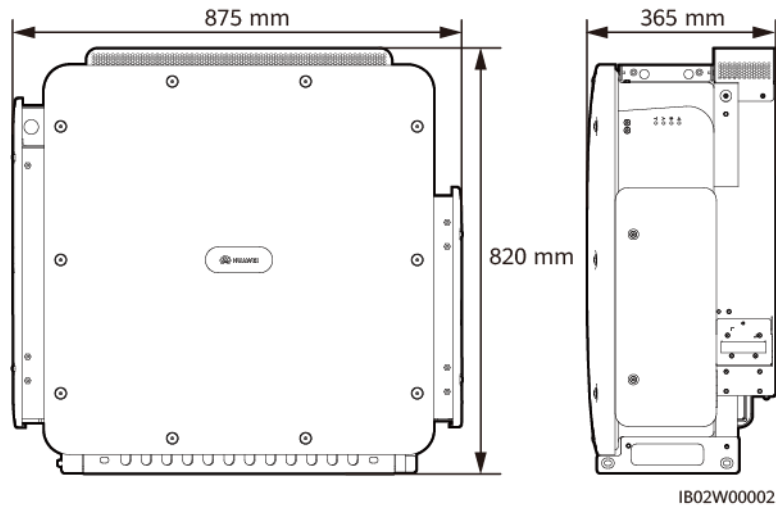

IB02W00002

## Indicator Description

You can check the operating status of the Smart PCS by observing the LED indicators on the panel.

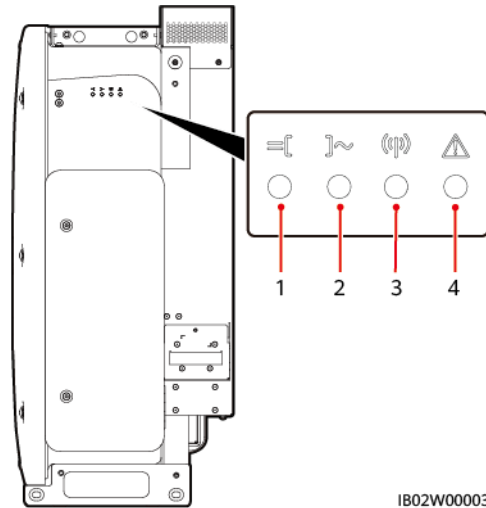

Figure 2-9 LED indicators



IB02W00003

Table 2-2 LED indicator description

No.	Category	Status (Blinking Fast: On for 0.2s and Off for 0.2s; Blinking Slowly: On for 1s and Off for 1s)	Meaning
1	DC indication 	Steady green	The DC side is properly connected, and the auxiliary power supply inside the device is working.

No.	Category	Status (Blinking Fast: On for 0.2s and Off for 0.2s; Blinking Slowly: On for 1s and Off for 1s)	Meaning
		Blinking green slowly	The device is in standby or cable connection detection state.
		Blinking red fast	An environmental fault occurred on the DC side.
		Off	The DC side is not properly connected, or the auxiliary power supply inside the device is not working.
2	Running indication 	Steady green	The device is operating in grid-tied mode.
		Steady yellow	The device is operating in off-grid mode.
		Blinking green slowly	The system environment is normal but the device is not in the working state.
		Blinking red fast	An environmental fault occurred on the AC side.
		Off	The AC side is not connected to the power grid.
3	Communication indication 	Blinking green fast	The device receives data through northbound FE communication.
		Off	The device has not received data through northbound FE communication in at least 10s.
4	Fault/Maintenance indication 	Steady red	A major alarm was generated on the device.
		Blinking red fast	A minor alarm was generated on the device.
		Blinking red slowly	A warning was generated on the device.
		Blinking green slowly	The device is under local maintenance or shut down after receiving a command.
		Off	There is no alarm, and no local maintenance operations are performed.

- If the Smart PCS is installed on the DC LV Panel (or the installation height is about 2.4 m), you are advised to use the SmartLogger or app to check the device running status. The optimal viewing range of the Smart PCS indicators is 3 m to 5 m, and the viewing angle is less than or equal to 15°.

Figure 2-10 Optimal viewing range of indicators

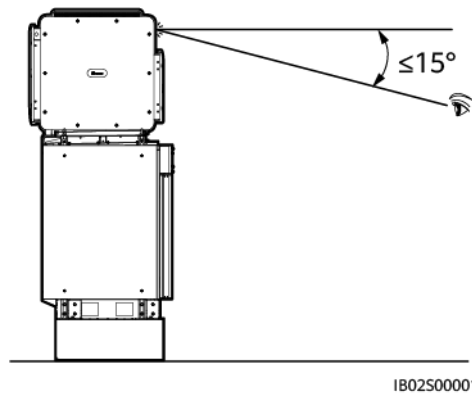

**NOTE**

- If the DC indicator and running indicator do not blink red fast and the fault/maintenance indicator is steady red, replace parts or the entire device.
- Local maintenance refers to the operation that requires inserting a WLAN module into the USB port of the device, for example, connecting to the SUN2000 app through the WLAN module.
- If alarms are generated during the local maintenance, the fault/maintenance indicator shows the local maintenance state first. After the WLAN module is removed, the indicator shows the alarm state.

## 2.4 Circuit Diagram

Figure 2-11 Circuit diagram

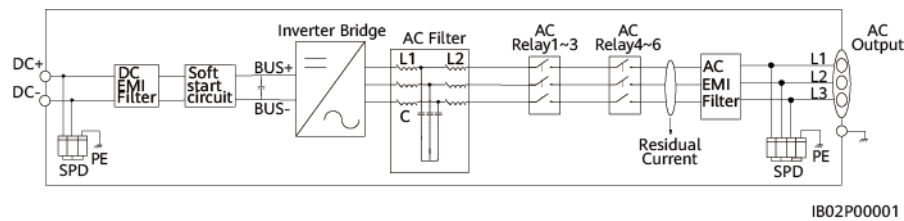

## 2.5 Working Modes

The Smart PCS has three working modes: standby, operating, and shutdown.

Figure 2-12 Working modes

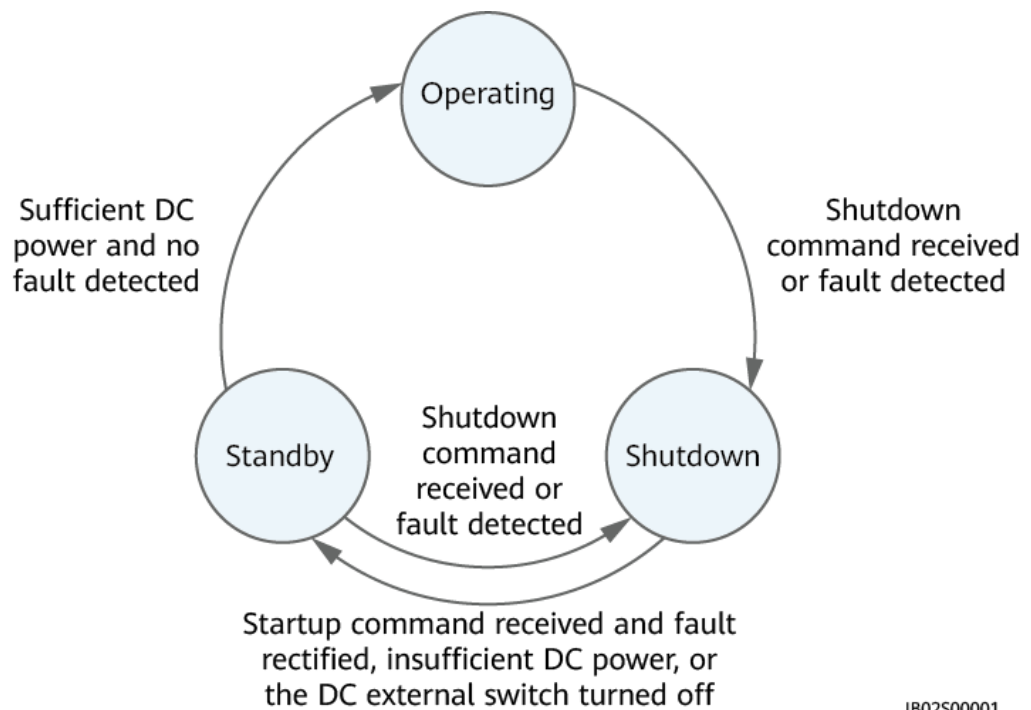









1B02S00001



Table 2-3 Working mode description

Working Mode	Description
Standby	<p>The Smart PCS enters standby mode when the external environment does not meet the operating requirements. In standby mode:</p> <ul style="list-style-type: none"> <li>• The Smart PCS continuously detects its operation status. Once the operation conditions are met, the Smart PCS enters operating mode.</li> <li>• If the Smart PCS detects a shutdown command or a fault after startup, it enters shutdown mode.</li> </ul>
Operating	<p>In operating mode:</p> <ul style="list-style-type: none"> <li>• The Smart PCS controls charge and discharge based on system commands.</li> <li>• The Smart PCS enters shutdown mode after detecting a fault or receiving a shutdown command.</li> </ul>
Shutdown	<ul style="list-style-type: none"> <li>• In standby or operating mode, if the Smart PCS detects a shutdown command or a fault, it enters shutdown mode.</li> <li>• In shutdown mode, the Smart PCS enters standby mode when a startup command is received and faults are rectified, the DC power is insufficient, or the DC external switch is turned off.</li> </ul>

## 2.6 Label Description

Table 2-4 Enclosure labels

Symbol	Name	Meaning
	Operation warning	Potential hazards exist after the device is powered on. Take protective measures when working on the device.
	High temperature hazard	Do not touch the device, as the enclosure is hot when the device is running.
	Electric shock hazard	Hazardous voltage exists after the device is powered on. Take protective measures during operation and maintenance (O&M).
	Delayed discharge	<ul style="list-style-type: none"> <li>High voltage may occur after the device is powered on. Only qualified and trained electrical technicians are allowed to install and operate the device.</li> <li>Residual voltage exists after the device is powered off. It takes 15 minutes for the device to discharge to the safe voltage.</li> </ul>
	Refer to documentation	Reminds operators to refer to the documentation provided with the device. Losses caused by operations that do not comply with the requirements of site selection, storage, or mounting specified in the user manual are not covered under the warranty.
	Protective earthing	Indicates the position for connecting the protective earthing (PE) cable.
	Equipotential bonding	Indicates the position for equipotential bonding.
	Fan operation warning	Do not touch the fan when the device is running to prevent mechanical injury.

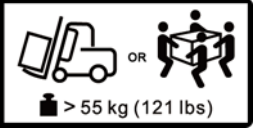
Symbol	Name	Meaning
 	Fan replacement warning	Before replacing the fan, disconnect its power connector.
 	Weight	The device needs to be carried by four persons or using a forklift.

# 3 Storage Requirements

## NOTICE

- Store Smart PCSs according to the storage requirements. Device damage caused by unqualified storage conditions is not covered under the warranty.
- Do not store Smart PCSs without outer packaging.
- Do not tilt a packing case or place it upside down.

If Smart PCSs will not be put into use immediately, store them according to the requirements specified in this section. Device damage caused by unqualified storage conditions is not covered under the warranty. Store Smart PCSs with outer packaging in a ventilated, dry, and clean indoor environment. In addition, ensure that the following requirements are met:

- If Smart PCSs are unpacked but will not be used immediately, put them back to the original packaging with the desiccant, and seal with tape.
- When temporarily storing Smart PCSs outdoors, do not stack them on a pallet. Take rainproof measures such as using tarpaulins to protect Smart PCSs from rain and water.
- Smart PCSs must be stored in a clean and dry environment with appropriate temperature and humidity. The air must not contain corrosive or flammable gases. Maintain a storage temperature between  $-40^{\circ}\text{C}$  to  $+70^{\circ}\text{C}$ , and humidity between 5%–95% RH.
- A maximum of four Smart PCSs can be stacked. To avoid personal injury or device damage, exercise caution when stacking Smart PCSs to prevent them from falling over.
- Do not remove the outer packaging. Check the packaging regularly (recommended: once every three months). Replace any packaging that is damaged during storage.
- Do not store Smart PCSs for more than two years. If Smart PCSs have been stored for two years or longer, they must be checked and tested by professionals before being put into use.

# 4 Installation

## 4.1 Installation Modes

The Smart PCS can be installed on a support, wall, or DC LV Panel (also referred to as DCBOX).

**Table 4-1** Installation modes

Installation Mode	Screw Specifications	Description
Wall mounting	M12x60 stainless steel expansion bolt	Prepared by the customer
Support mounting	M12 bolt assembly	Prepared by the customer
DCBOX mounting	-	Purchased from the Company

## 4.2 Installation Requirements

### 4.2.1 Site Selection Requirements

- Do not install the Smart PCS in working or living areas to avoid personal injury or property loss caused by accidental contact by non-professionals or other reasons during device operation.
- Do not install the Smart PCS in noise-sensitive areas (such as residential areas, office areas, and schools) to avoid complaints. If the preceding areas are unavoidable, the distance between the installation position and noise-sensitive areas must be greater than or equal to 40 m.
- If the Smart PCS is installed in public places (such as parking lots, stations, and factories) other than working and living areas, install a protective net

outside the device and set up a safety warning sign to isolate the device. This is to avoid personal injury or property loss caused by accidental contact by non-professionals or other reasons during device operation.

- Do not install the Smart PCS in areas containing flammable materials (such as sulfur, phosphorus, liquefied petroleum gas, marsh gas, flour, and cotton) to avoid personal injury or property loss caused by fire or other reasons.
- Do not install the Smart PCS in areas containing explosives (such as blasting agents, display shells, fireworks, and firecrackers) to avoid personal injury or property loss caused by explosion or other reasons.
- Do not install the Smart PCS in areas with corrosive substances (such as sulfuric acid, hydrochloric acid, nitric acid, hydrogen sulfide, and chlorine) to avoid Smart PCS failure caused by corrosion, which is not covered under the warranty.
- The mounting structure for the Smart PCS must be fireproof. Do not install the Smart PCS on flammable building materials to avoid personal injury or property loss caused by fire or other reasons.
- The anti-corrosion level of the Smart PCS is C5 Medium. Therefore, the site must be a class C or better environment but not a class D or E environment.
- Do not install the Smart PCS in an easily accessible place, because the voltage is high and its enclosure and heat sink are hot during device operation. This is to avoid personal injury or property loss caused by accidental contact by non-professionals or other reasons during device operation.
- The Smart PCS shall be installed in a well-ventilated environment to ensure good heat dissipation. The Smart PCS provides self-protection in high-temperature environments. If the Smart PCS is installed in a poorly ventilated environment, the power of the Smart PCS may decrease as the ambient temperature increases.
- Do not install the equipment in an area with strong vibration, noise, or electromagnetic interference. The equipment shall be installed in an environment with a magnetic field strength less than 4 Gauss. If the magnetic field strength is greater than or equal to 4 Gauss, the equipment may fail to work properly. If the magnetic field strength is high, for example, in a smeltery, you are advised to use a gauss meter to measure the magnetic field strength of the equipment installation position when the smelting equipment is running normally.
- If the Smart PCS is installed in an enclosed environment, a heat dissipation device or ventilation device shall be installed. The indoor ambient temperature must not be higher than the outdoor ambient temperature. The Smart PCS provides self-protection in high-temperature environments. The power of the Smart PCS may decrease as the ambient temperature increases.
- In off-grid scenarios, install the Smart PCS in a place with a sunshade or install an awning for the Smart PCS in case of high temperature or direct sunlight.
- The Smart PCS shall be installed in a sheltered place to avoid exposure to direct sunlight or adverse weather conditions (such as snow, rain, and lightning). The Smart PCS provides self-protection in high-temperature environments. If the Smart PCS is installed in a place subject to direct sunlight, the power of the Smart PCS may decrease as the ambient temperature increases.

- Ensure that the installation surface is solid enough to bear the weight of the Smart PCS (for details, see [Figure 4-1](#)) to avoid personal injury or property loss caused by the collapse of the mounting structure or other reasons.
- Take waterproof and insulation measures for unused DC power cables to avoid personal injury or property loss caused by accidental contact with high voltage or other reasons.
- AC and DC power cables must be vertically routed into combiner boxes and wiring terminals to avoid damage caused by horizontal stress on the terminals, which is not covered under the warranty.
- The Smart PCS will be corroded in salt-affected areas. Before installing the Smart PCS outdoors in salt-affected areas, consult the Company. A salt-affected area refers to a region within 500 m of the coast or prone to sea breeze. Regions prone to sea breeze vary with weather conditions (such as typhoons and monsoons) or terrains (such as dams and hills).

 **NOTE**

- Class C environment: Outdoor areas more than 500 m away from the sea. If a site is near a pollution source, it is 1500–3000 m away from heavy pollution sources, such as smelters, coal mines, and thermal power plants; 1000–2000 m away from medium pollution sources such as chemical factories, rubber plants, and electroplating factories; or 500–1000 m away from light pollution sources, such as packing houses, tanneries, boiler rooms, slaughterhouses, landfill sites, and sewage treatment plants.
- Class D environment: Sea environments or outdoor areas within 500 m away from the sea. If a site is near a pollution source, it is within 1500 m away from heavy pollution sources such as smelters, coal mines, and thermal power plants; within 1000 m away from medium pollution sources such as chemical factories, rubber plants, and electroplating factories; or within 500 m away from light pollution sources such as packing houses, tanneries, boiler rooms, slaughterhouses, landfill sites, and sewage treatment plants.
- Class E environment: Special environments, such as underground or underwater environments.

## 4.2.2 Mounting Structure Requirements

- The structure where the device is installed must be fireproof.
- Do not install the device on flammable building materials.
- The device is heavy. Ensure that the installation surface is solid enough to bear the weight of the device.
- In residential areas, do not install the device on gypsum boards or walls made of similar materials with weak sound insulation performance to avoid disturbing residents.
- Ensure that the installation surface is solid enough to bear the weight of the Smart PCS (for details, see [Figure 4-1](#)) to avoid personal injury or property loss caused by the collapse of the mounting structure or other reasons.

Figure 4-1 Mounting structure

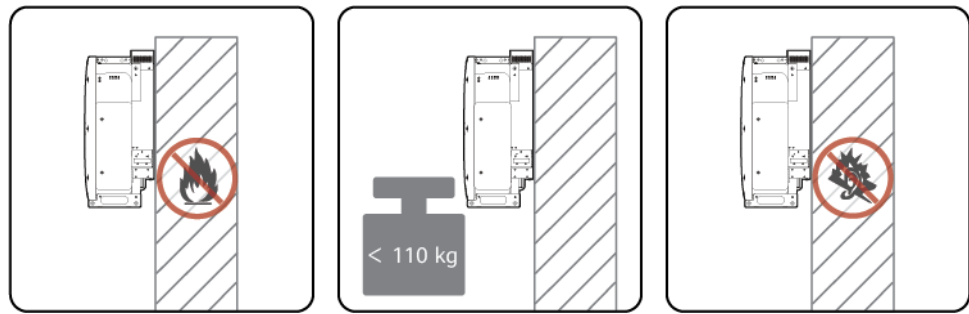

### 4.2.3 Clearance Requirements

Reserve sufficient clearance around the Smart PCS for installation and heat dissipation.

Figure 4-2 Installation clearance (support-mounting and wall-mounting scenarios)

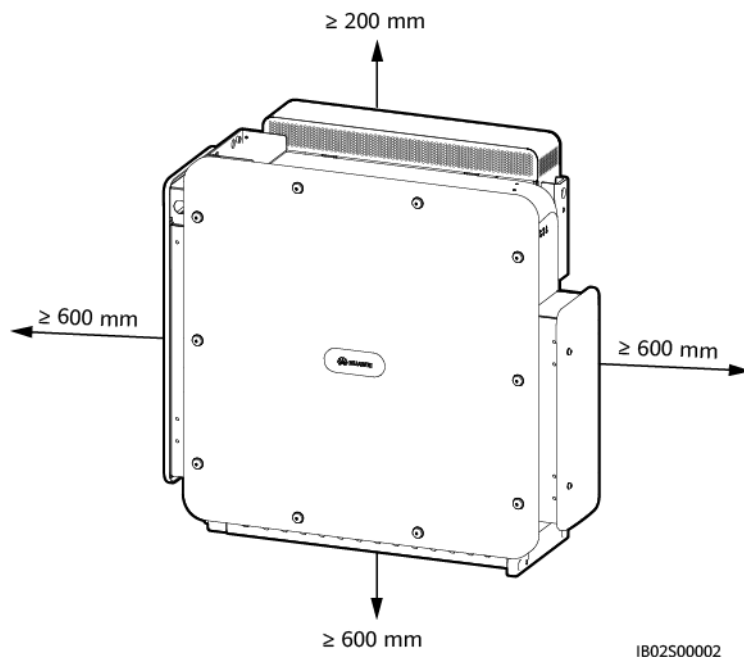

**NOTE**

For ease of installation, cable connection, and maintenance, reserve 600–730 mm clearance underneath. For further questions regarding the clearance, consult local technical support engineers.

When installing multiple devices, install them in horizontal mode if sufficient space is available and install them in triangle mode if no sufficient space is available. Stacked installation is not recommended.

**Figure 4-3** Horizontal installation (recommended)

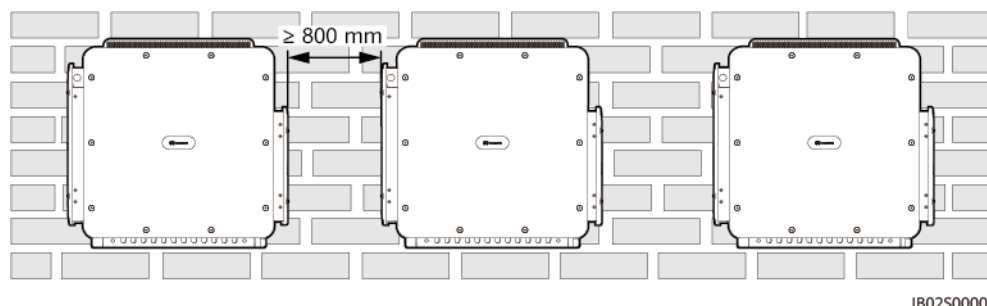

IB02S00004

**Figure 4-4** Triangle installation mode (recommended)

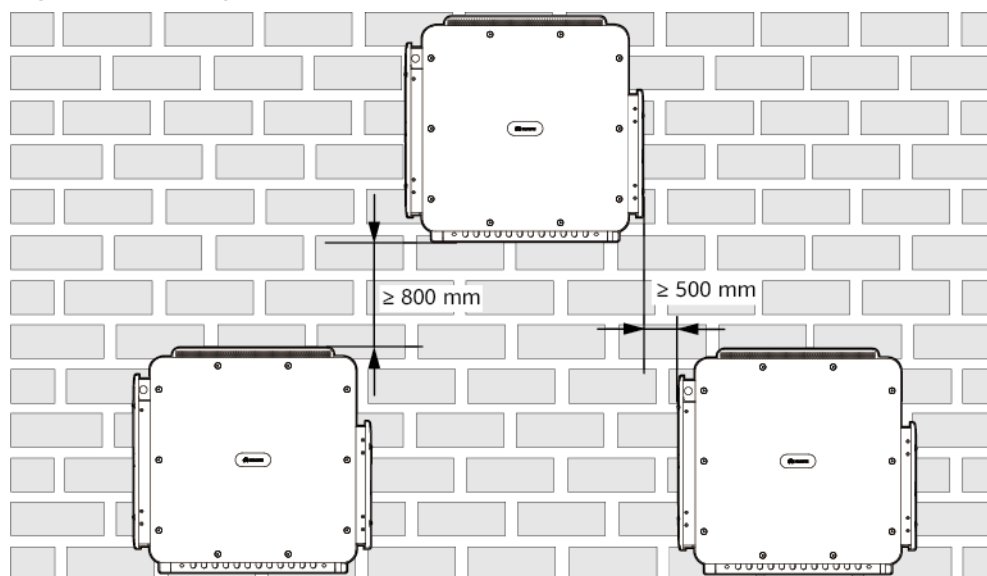

IB02S00005

**Figure 4-5** Stacked installation mode (not recommended)

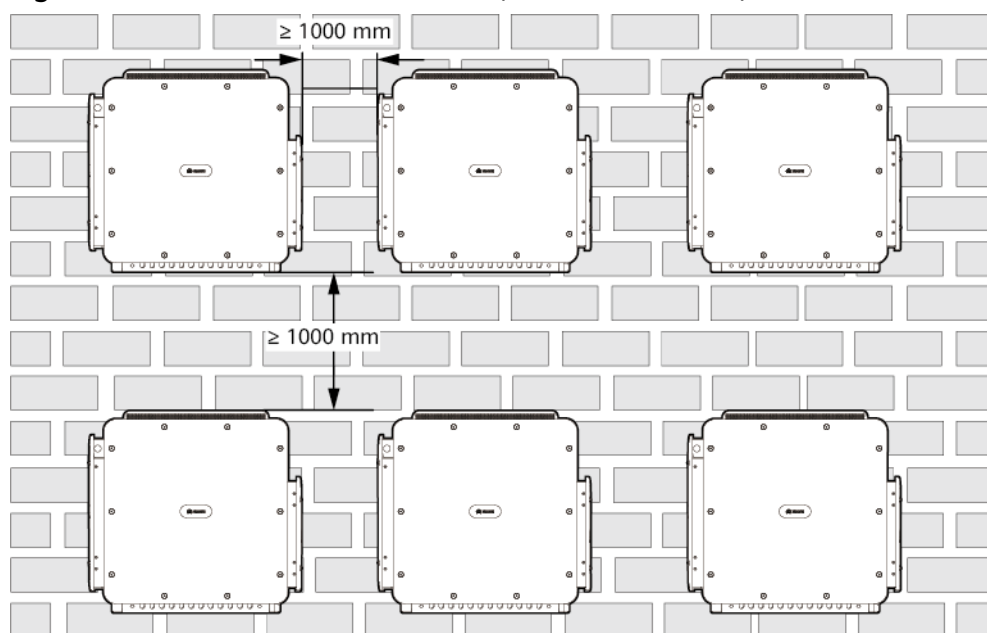

IB02S00006

## 4.2.4 Angle Requirements

Figure 4-6 Installation angle

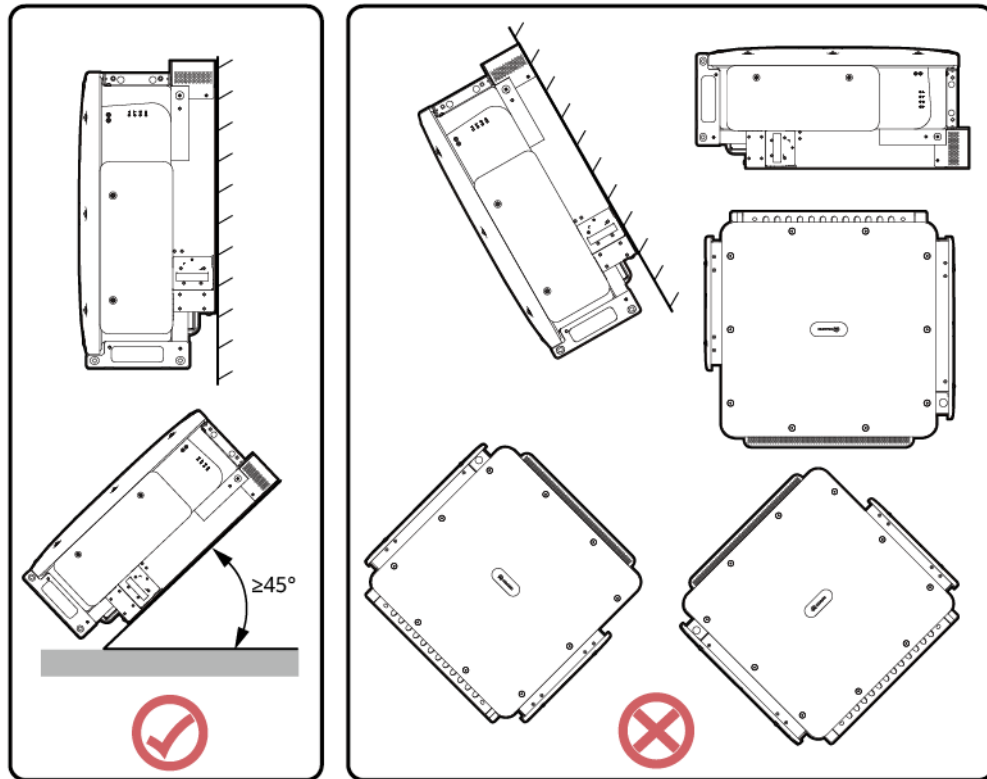









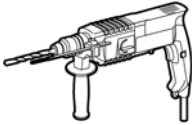

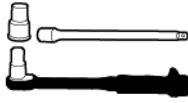
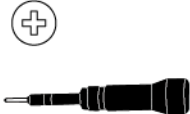

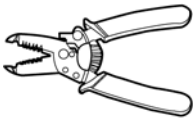

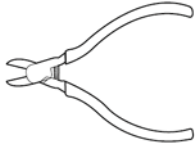

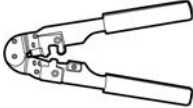
1B02500003

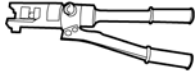

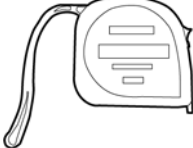
## 4.3 Preparing Tools

Before installation, the following tools need to be prepared.



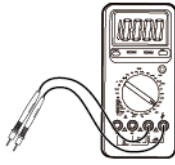

### Installation Tools

			
<p>Hammer drill</p>	<p>Drill bit (<math>\Phi 14</math> mm and <math>\Phi 16</math> mm)</p>	<p>Insulated torque socket wrench (including an extension bar <math>\geq 50</math> mm)</p>	<p>Phillips insulated torque screwdriver</p>

 <p>Wire stripper</p>	 <p>Rubber mallet</p>	 <p>Utility knife</p>	 <p>Diagonal pliers</p>
 <p>Cable cutter</p>	 <p>RJ45 crimping tool</p>	 <p>Vacuum cleaner</p>	 <p>Hydraulic pliers</p>
 <p>Marker</p>	 <p>Steel measuring tape</p>	 <p>Level</p>	 <p>Cable tie</p>
 <p>Heat shrink tubing</p>	 <p>Heat gun</p>	 <p>Ladder</p>	 <p>Digital multimeter</p> <p>DC voltage measurement range <math>\geq 1500</math> V DC</p> <p>AC voltage measurement range <math>\geq 800</math> V AC</p>

 <p>Crane Hoisting capability ≥ 3 t; working radius ≥ 2 m</p>	 <p>Lifting sling Length ≥ 1.8 m</p>	-	-
--	---	---	---

### Personal Protective Equipment (PPE)

 <p>Insulated gloves</p>	 <p>Goggles</p>	 <p>Dust mask</p>	 <p>Insulated shoes</p>
 <p>Reflective vest</p>	 <p>Safety helmet</p>	 <p>Protective gloves</p>	-

## 4.4 Pre-installation Check

### Checking Outer Packaging

#### NOTICE

- After placing the equipment in the installation position, unpack it with care to prevent scratches. Keep the equipment stable during unpacking.

Before unpacking the device, check the outer packaging for damage, such as holes and cracks, and check the device model. If any damage is found or the device model is not what you requested, do not unpack the product and contact your vendor as soon as possible.

 NOTE

You are advised to remove the outer packaging within 24 hours before installing the device.

## Unpacking the Device

**Step 1** Use diagonal pliers to cut the packaging tape, and use a utility knife to slice the tape along the gap on the packing case. Slice the tape with caution to avoid scratching the device inside.

**Step 2** Open the packing case and check the deliverables.

----End

## Checking Deliverables

After unpacking the device, check that the deliverables are intact and complete according to the packing list, and check that the device is free from any obvious damage. If any item is missing or damaged, contact your vendor.

 NOTE

For details about the quantity of deliverables, see the *packing list* in the packing case.

# 4.5 Moving the Smart PCS

## Precautions

---

 CAUTION

Ensure that the lifting handles are installed to the correct screw holes. Do not install them to the mounting bracket screw holes on the top. Incorrect installation may cause device damage or personal injury.

---

**NOTICE**

- Four persons or appropriate transportation tools are required to move the device.
  - Place a foam pad or cardboard under the device to protect its enclosure from damage.
  - Use lifting handles to facilitate installation, which are optional and delivered separately. Ensure that the lifting handles are securely installed. After the installation is complete, remove the lifting handles and keep them properly.
  - Secure the lifting handles (with the steel washers of the lifting handles closely fitted to the device).
  - If the stud of a lifting handle is bent, replace the lifting handle in time.
  - Slowly and steadily hoist, land, and move the Smart PCS to avoid bumping and damaging the device enclosure.
-

## Method

If the installation position is high and a crane is required, run a sling (strong enough to bear the weight of the Smart PCS) through the two lifting eyes to hoist the Smart PCS.

**Table 4-2** Method description

Method	Tool	Description
Manual handling	Lifting handles	Prepared by the customer
Hoisting	Crane sling <sup>[1]</sup>	Prepared by the customer

Note [1]: The hoisting capability of the crane shall be greater than or equal to 3 t, the working radius shall be greater than or equal to 2 m, and the length of the lifting sling shall be greater than or equal to 1.8 m. To prevent damage to the device surfaces, you are advised not to use metal slings such as steel wire ropes.

## Hole Description

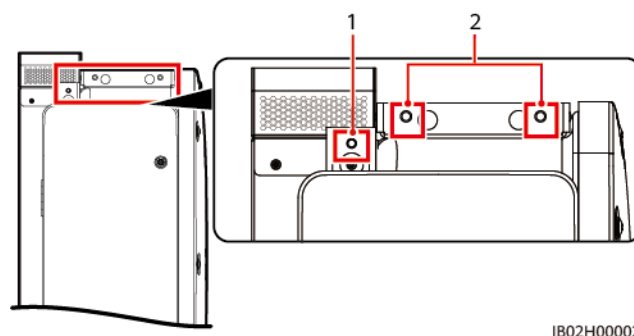

IB02H00002

(1) Lifting handle screw hole

(2) Mounting bracket screw holes

## Procedure

**Step 1** Take the device out of the packing case and move it to the specified position.

**Figure 4-7** Using the lifting handles

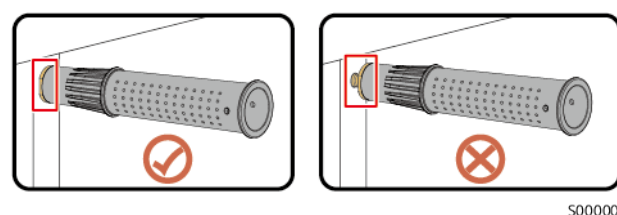

S000004

Figure 4-8 Manual handling

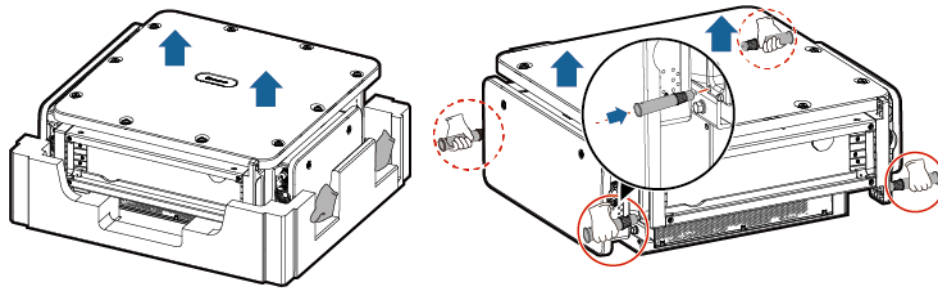

IB02H00004

Figure 4-9 Hoisting

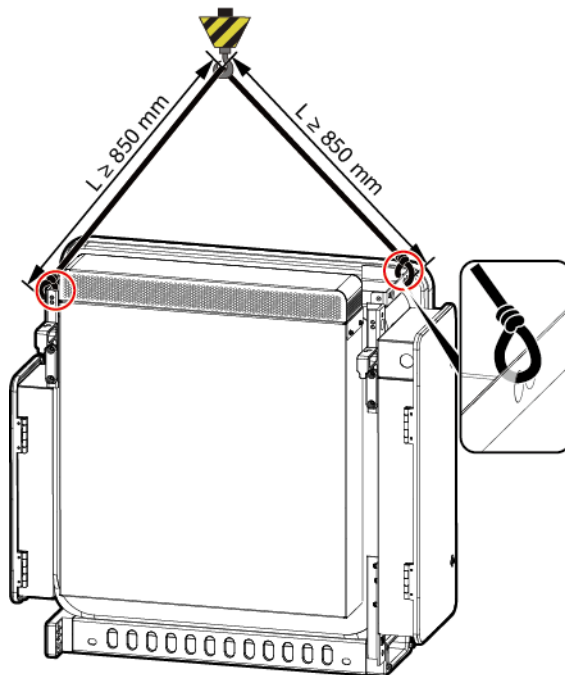

IB02H00006

----End

## 4.6 Support Mounting

### Mounting Bracket Dimensions

Purchase the mounting bracket separately from the Company.

The mounting bracket of the Smart PCS has four groups of tapped holes, each group containing four tapped holes. Mark any hole in each group based on site requirements and mark four holes in total. The two round holes are recommended.

**Figure 4-10** Hole dimensions

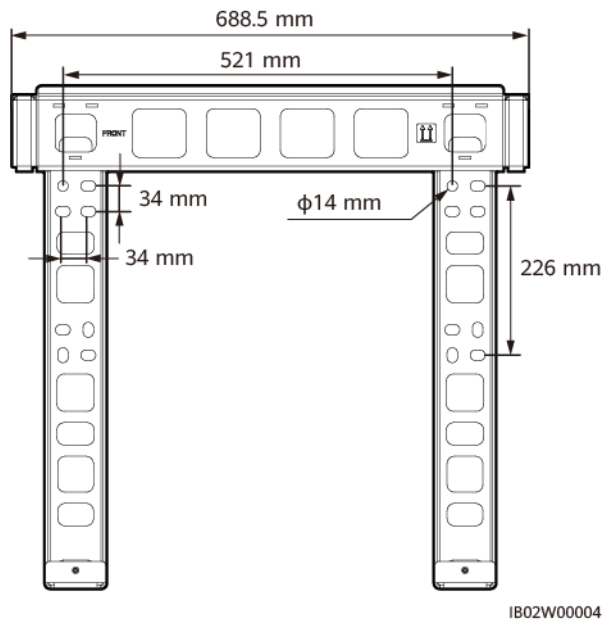

## Procedure

**Step 1** Install the mounting bracket.

**Figure 4-11** Installing the mounting bracket

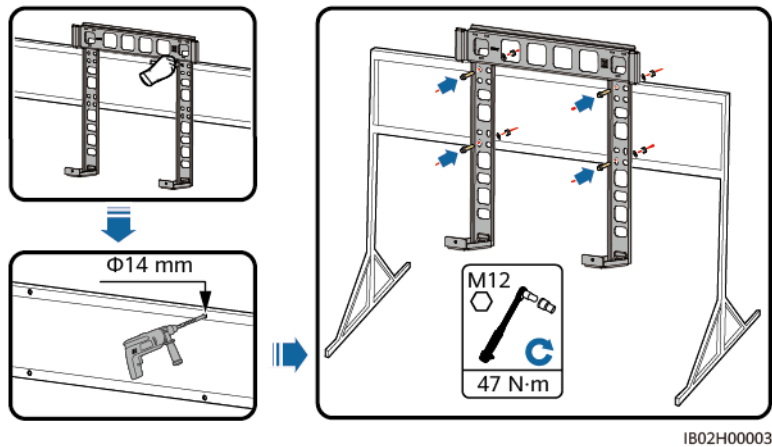

### NOTE

If the bolt length does not meet the installation requirements, prepare M12 bolts and use them together with the delivered M12 nuts.

**Step 2** Install the mounting ears.

Figure 4-12 Installing the mounting ears

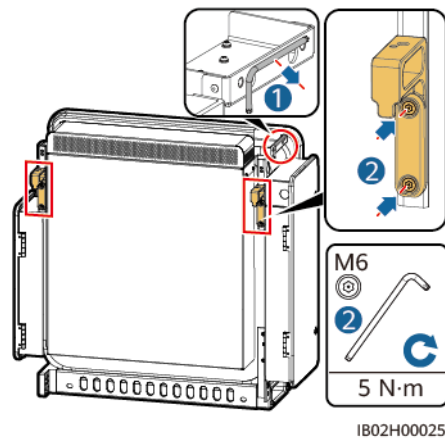

**Step 3** Install the device on the mounting bracket.

**Step 4** Tighten the two screws at the bottom of the device.

Figure 4-13 Installing the Smart PCS

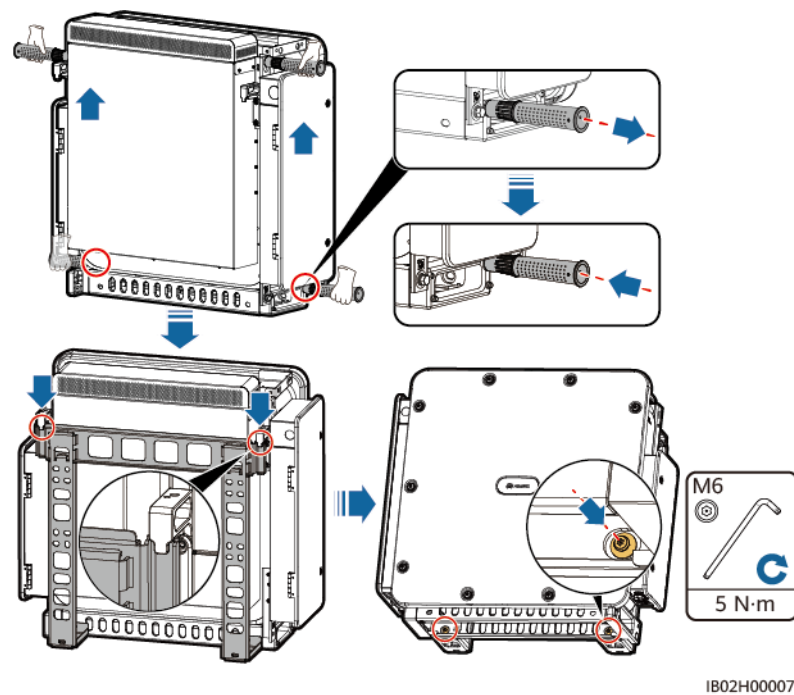

----End

## 4.7 Wall Mounting

### Precautions



Avoid drilling holes into the water pipes and power cables buried in the wall.

**NOTICE**

- To prevent dust inhalation or contact with eyes, wear safety goggles and a dust mask when drilling holes.
- Use a vacuum cleaner to clean up dust in and around the holes, and measure the spacing. If the holes are inaccurately positioned, drill the holes again.
- Level the top of the expansion sleeve with the concrete wall after removing the bolt, spring washer, and flat washer. Otherwise, the mounting bracket will not be securely installed on the concrete wall.

## Mounting Bracket Dimensions

Purchase the mounting bracket separately from the Company. The M12x60 stainless expansion bolts need to be purchased separately.

The mounting bracket of the Smart PCS has four groups of tapped holes, each group containing four tapped holes. Mark any hole in each group based on site requirements and mark four holes in total. The two round holes are recommended.

**Figure 4-14** Hole dimensions

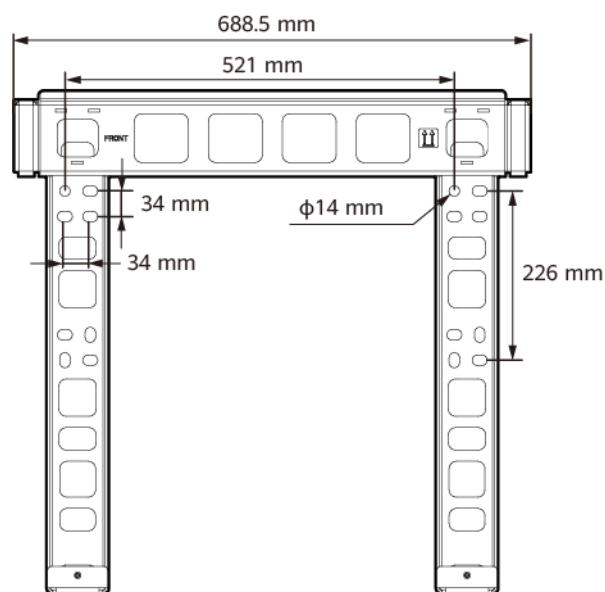

## Procedure

- Step 1** Install the mounting bracket.

**Figure 4-15** Installing the mounting bracket

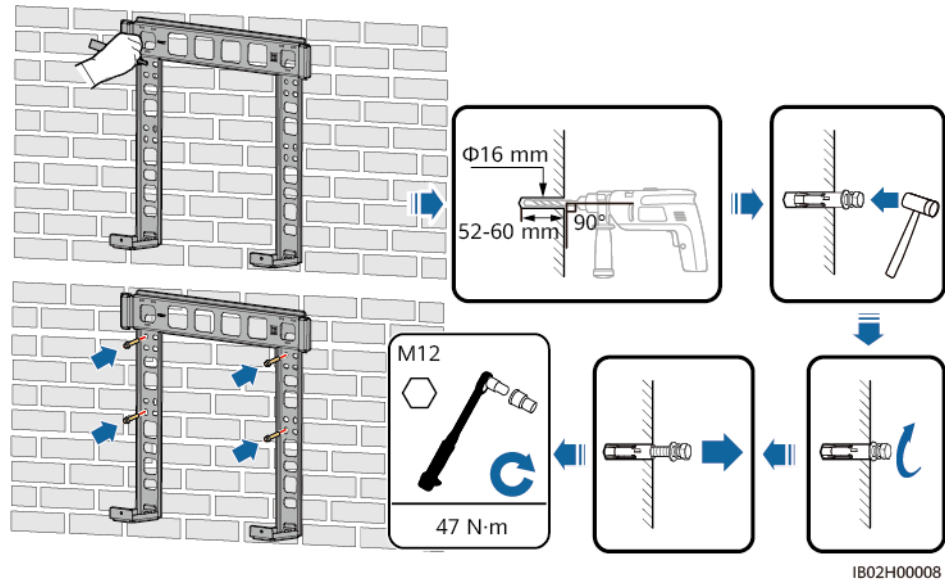

**Step 2** Install the mounting ears.

**Figure 4-16** Installing the mounting ears

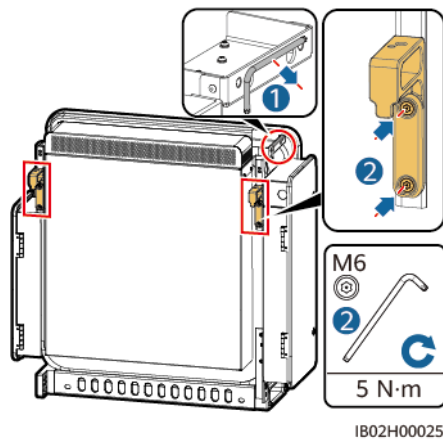

**Step 3** Install the device on the mounting bracket.

**Step 4** Tighten the two screws at the bottom of the device.

Figure 4-17 Installing the Smart PCS

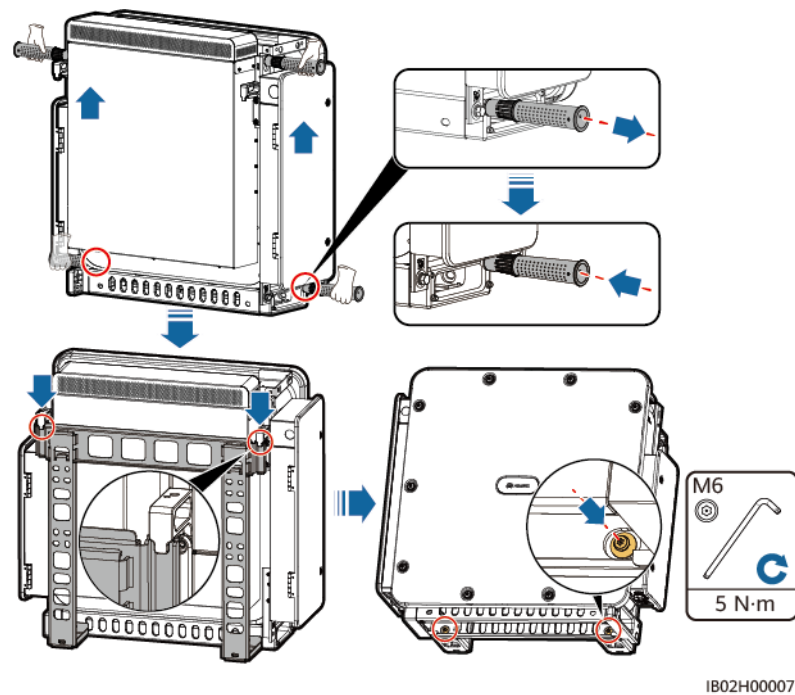

----End

## 4.8 DCBOX Mounting

### Installation Description

- The DCBOX-9/5-H0 is purchased from the Company.
- For details about the installation procedure, see the [DCBOX DC LV Panel User Manual](#).

#### NOTE

- A maximum of five Smart PCSs can be installed on the top of the DCBOX. If less than five Smart PCSs will be installed, install them from left to right. Otherwise, the Smart PCS fasteners cannot be used.
- The installation method of all Smart PCSs is the same. Install the Smart PCS according to the direction shown in the figure. This section uses one Smart PCS as an example.

## Installation Diagram

Figure 4-18 Installation diagram

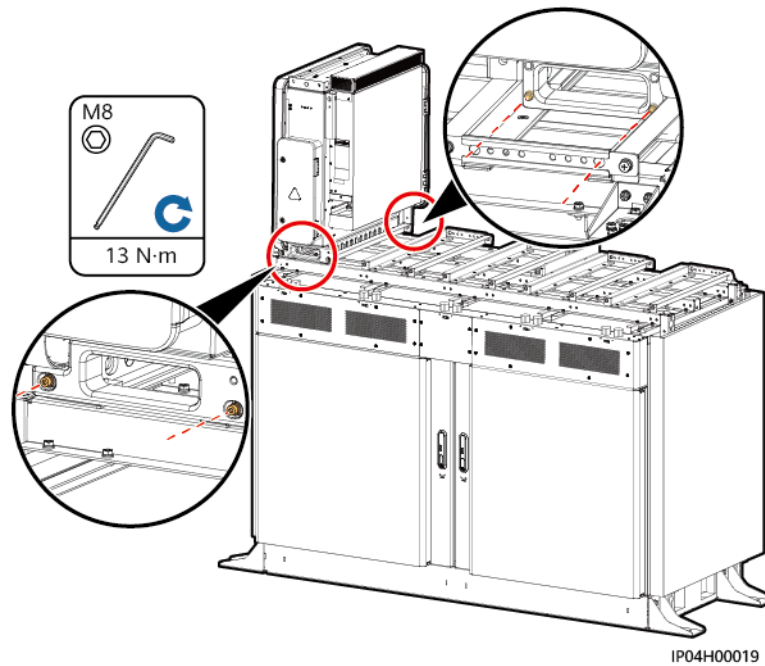

### NOTE

After the Smart PCS is secured, you need to configure a DC power distribution cabinet by yourself. For details about the specifications, contact local technical support engineers.

# 5 Cable Connection

---

## 5.1 Precautions

---

### DANGER

- Before connecting cables, ensure that the external switches on the AC and DC sides of the Smart PCS are off to disconnect all external connections of the Smart PCS. Otherwise, the high voltage of the device may cause electric shocks.
  - The site must be equipped with qualified fire fighting facilities, such as fire sand and carbon dioxide fire extinguishers.
  - Wear personal protective equipment and use dedicated insulated tools to avoid electric shocks or short circuits.
- 

---

### WARNING

- Device damage caused by incorrect cable connections is not covered by the product warranty.
  - Only professional electrical technicians are allowed to perform electrical connection operations.
  - Connect cables according to the wiring labels inside the device.
  - Operation personnel must wear PPE when connecting cables.
  - Before connecting cables to ports, leave enough slack to reduce the tension on the cables and prevent poor cable connections.
- 

---

### CAUTION

- Stay away from the equipment when preparing cables to prevent cable scraps from entering the equipment. Cable scraps may cause sparks and result in personal injury and equipment damage.
-

 NOTE

The cable colors shown in the electrical connection diagrams provided in this section are for reference only. Select cables in accordance with local cable specifications (green-and-yellow cables are only used for protective earthing). The factors that affect cable selection include the rated current, cable type, routing mode, ambient temperature, and maximum expected line loss.

## 5.2 Preparing Cables

**Table 5-1** Cable description (S indicates the conductor cross-sectional area of the AC cable, and  $S_p$  indicates the conductor cross-sectional area of the PE cable)

Cable	Type	Conductor Cross-Sectional Area	Outer Diameter	Source
DC power cable (multi-core)	Two-core outdoor cable and M12 OT/DT terminal	70–185 mm <sup>2</sup>	30–60 mm	Prepared by the customer (In the DCBOX scenario, the DC cables are preinstalled on the DCBOX and do not need to be prepared.)
DC power cable (single-core)	Single-core outdoor cable and M12 OT/DT terminal	50–185 mm <sup>2</sup>	15–35 mm	Prepared by the customer (In the DCBOX scenario, the DC cables are preinstalled on the DCBOX and do not need to be prepared.)
PE cable <sup>[1]</sup>	Single-core outdoor copper cable and M10 OT/DT terminal	$S_p \geq S/2$	-	Prepared by the customer
Communications cable	FE: CAT 5E outdoor shielded network cable (internal resistance $\leq 1$ ohm/10 m) and the shielded RJ45 connector	0.2 mm <sup>2</sup>	4.5–7.5 mm	<ul style="list-style-type: none"> <li>• 1.2 m, delivered with the device</li> <li>• You can also prepare a cable according to site requirements.</li> </ul>

Cable	Type	Conductor Cross-Sectional Area	Outer Diameter	Source
AC power cable (multi-core)	Three-core (L1, L2, L3) outdoor cable and M12 OT/DT terminal (L1, L2, L3)	70–240 mm <sup>2</sup>	30–65 mm	Prepared by the customer
AC power cable (single-core)	Single-core outdoor cable and M12 OT/DT terminal	70–240 mm <sup>2</sup>	15–35 mm	Prepared by the customer

Note [1]: The  $S_p$  value is valid only if the conductors of the PE cable and AC power cable use the same material. If the materials are different, ensure that the conductor cross-sectional area of the PE cable produces a conductance equivalent to that specified in this table. The specifications of the PE cable are subject to this table or calculated according to IEC 60364-5-54.

## 5.3 Connecting a PE Cable

### Precautions

#### NOTICE

- The grounding shall comply with the local electrical safety regulations.
- It is recommended that the Smart PCS be connected to a nearby ground point. The ground points of all Smart PCSs in the same array need to be connected to ensure equipotential bonding for PE cables.
- The ground point in the AC maintenance compartment serves only as the equipotential bonding point for the PE point and cannot replace the PE point of the enclosure.

### Procedure

- Step 1** Connect the PE cable.

**Figure 5-1** Connecting the PE cable (AC side of the enclosure)

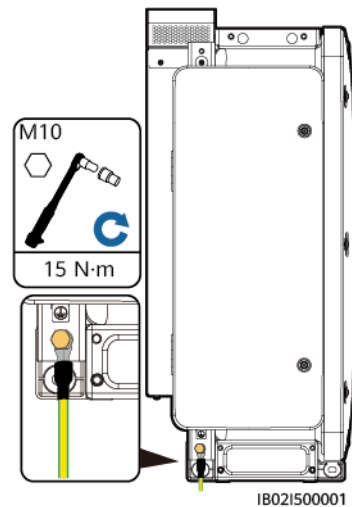

----End

## Follow-up Procedure

To enhance the corrosion resistance of a ground terminal, apply silicone grease or paint on it after connecting the PE cable.

## 5.4 Opening the Maintenance Compartment Door

### Precautions

---

#### NOTICE

- Do not open the panel of the Smart PCS.
  - Before opening a maintenance compartment door of the Smart PCS, turn off the external switches on the AC and DC sides.
  - Do not open the maintenance compartment door on rainy or snowy days. If you need to, take protective measures to prevent rain or snow from entering the maintenance compartment. If protective measures cannot be taken, do not open the maintenance compartment door.
  - Do not leave unused screws in the maintenance compartment.
- 

### 5.4.1 Opening the DC Maintenance Compartment Door

**Step 1** Open the DC maintenance compartment door.

**Figure 5-2** Opening the DC maintenance compartment door

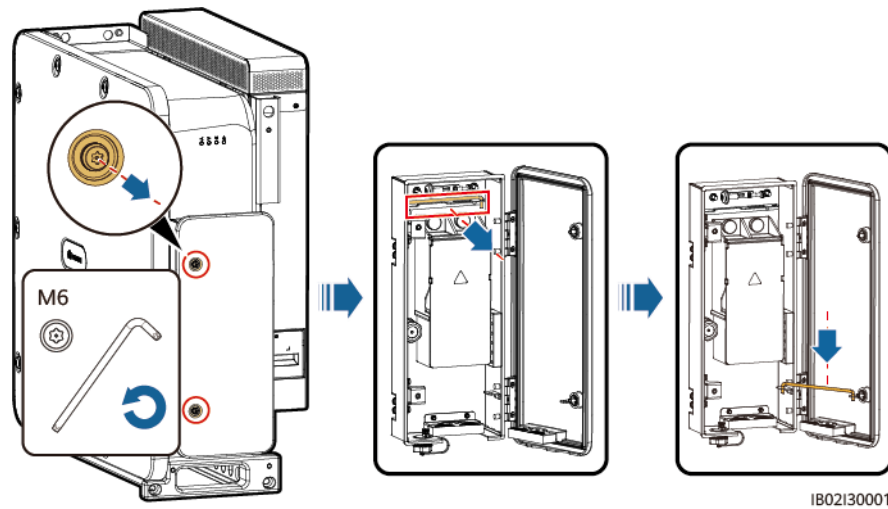

**Step 2** Remove the accessories from the DC maintenance compartment and store them properly for future use.

**Figure 5-3** Removing accessories from the DC maintenance compartment

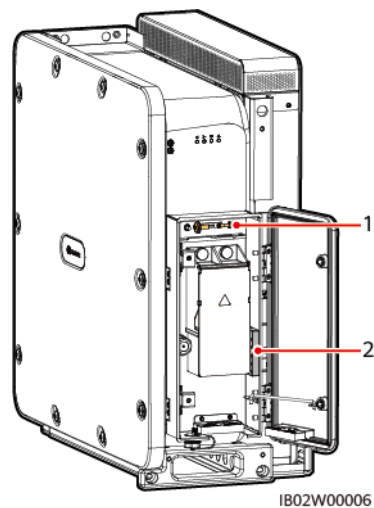

(1) Spare screws on the door panel of the maintenance compartment      (2) Crimping module

----End

## 5.4.2 Opening the AC Maintenance Compartment Door

**Step 1** Open the AC maintenance compartment door.

**Figure 5-4** Opening the AC maintenance compartment door

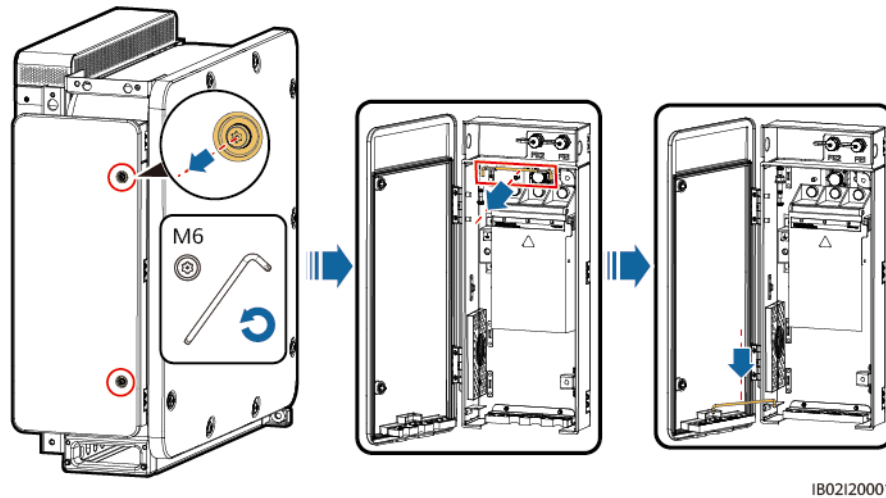

**Step 2** Remove the accessories from the AC maintenance compartment and store them properly for future use.

**Figure 5-5** Removing accessories from the AC maintenance compartment

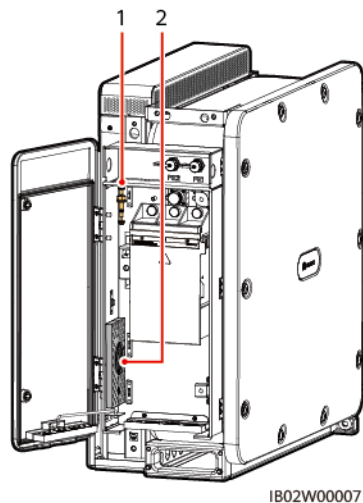

(1) Spare screws on the door panel of the maintenance compartment      (2) Crimping module

----End

## 5.5 (Optional) Replacing Crimping Modules

### NOTE

If AC and DC power cables are multi-core cables, replace the crimping modules.

**Step 1** Replace the crimping modules.

**Figure 5-6** Replacing the crimping module (on the DC side)

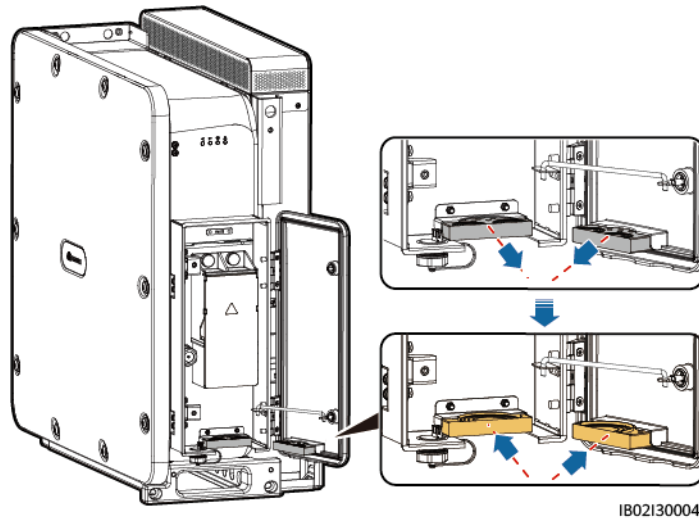

**Figure 5-7** Replacing the crimping module (on the AC side)

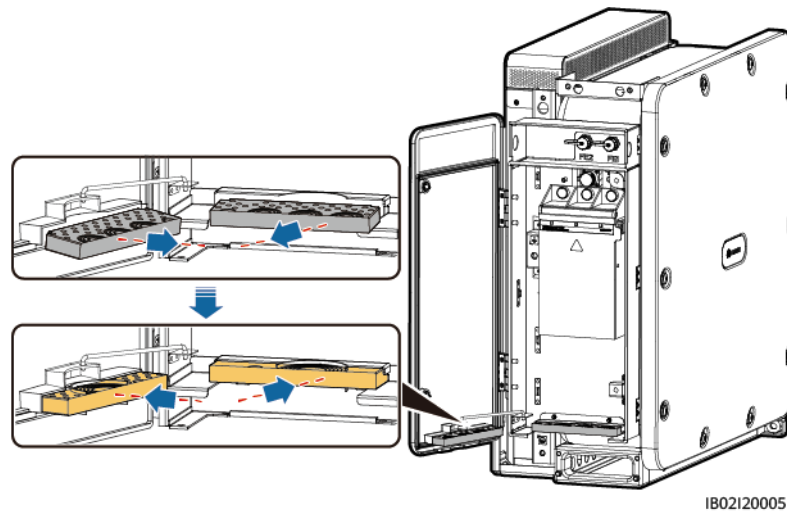

----End

## 5.6 Connecting DC Power Cables

### Precautions

Before connecting the DC power cables, check the following items:

- Check that the DC switches between the DC side of the Smart PCS and the DC LV Panel busbar are off.
- Check the polarities of the cables and label them properly.

### NOTICE

- The cable outer diameter can be measured using the ruler sticker in the maintenance compartment.
- Ensure that the cable jacket is in the maintenance compartment.
- Ensure that the DC power cables are connected securely. Otherwise, the Smart PCS may fail to operate, or be overheated in operation due to unreliable connection, which will damage the terminal block.
- Do not pull the cables horizontally after they have been secured, as this may damage the wiring terminals.

## Procedure

**Step 1** Prepare the cables. For details, see [A Crimping an OT or DT Terminal](#).

**Step 2** Remove a rubber ring based on the cable diameter range. Cut off the joints between rubber rings using scissors and then remove the rubber ring. All rubber rings are removed in the same way.

### NOTE

Remove a rubber ring strictly based on the cable diameter range and ensure that the crimping module is not damaged. Otherwise, the ingress protection (IP) rating of the device will be affected.

**Figure 5-8** Removing a rubber ring

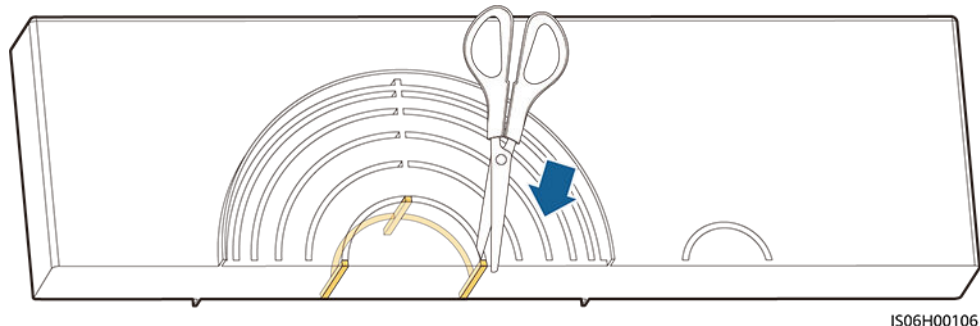

**Step 3** Connect the DC power cables to the terminal block and ensure that the cables are securely connected.

**Figure 5-9** Single-core cable connection (recommended)

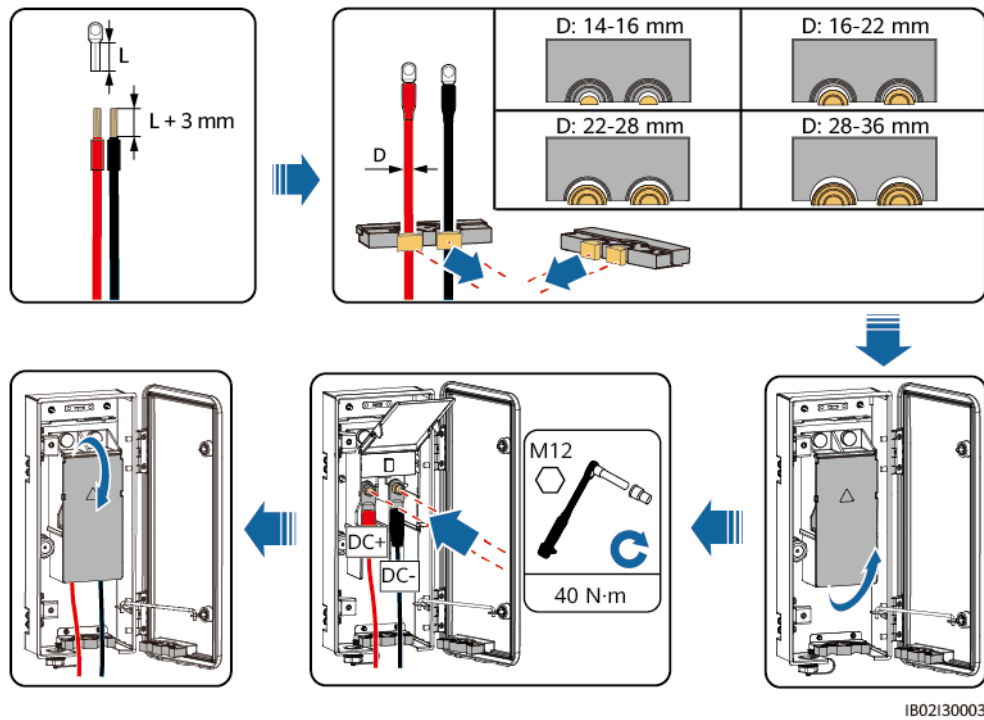

**Figure 5-10** Multi-core cable connection (not recommended)

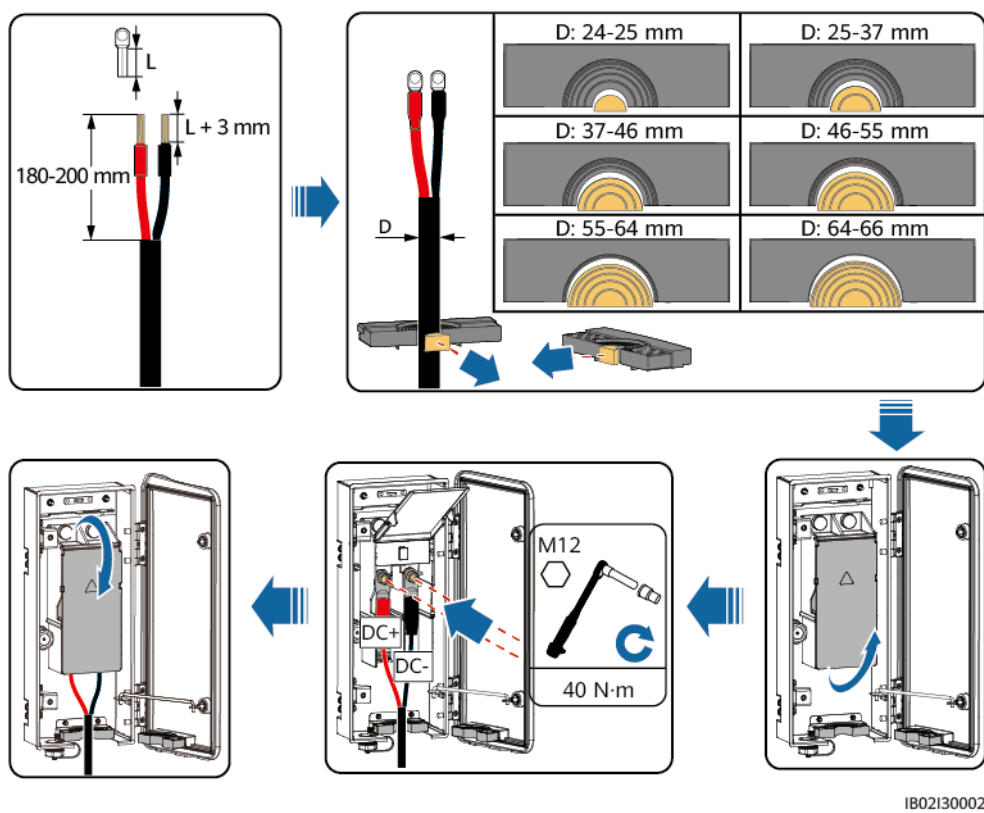

----End

## 5.7 Connecting AC Power Cables

### Precautions

A three-phase AC switch shall be installed on the AC side of the Smart PCS. To ensure that the Smart PCS can be safely disconnected from the power grid when an exception occurs, select a proper overcurrent protection device in compliance with local power distribution regulations.

---

#### WARNING

- Do not connect loads between a PCS and an AC switch that directly connects to the PCS. Otherwise, the switch may trip by mistake.
- If an AC switch is used with specifications beyond local standards, regulations, or the Company's recommendations, the switch may fail to turn off in a timely manner in case of exceptions, causing serious faults.

---

#### CAUTION

Each PCS shall be equipped with an AC output switch. Multiple PCSs shall not connect to the same AC switch.

---

#### NOTICE

- The cable outer diameter can be measured using the ruler sticker in the maintenance compartment.
- If a cable has a jacket, ensure that the jacket is in the maintenance compartment.
- Ensure that the AC power cables are connected securely. Otherwise, the Smart PCS may fail to operate, or be overheated in operation due to unreliable connection, which will damage the terminal block.
- Do not pull the cables horizontally after they have been secured, as this may damage the wiring terminals.
- The AC power cables to all Smart PCSs in an array shall be connected in the sequence of L1, L2, and L3. The phase sequence shall be consistent with that of the transformer station.

---

**Step 1** Prepare cables by referring to the section [Crimping an OT or DT Terminal](#).

**Step 2** Remove a rubber ring based on the cable diameter range. Cut off the joints between rubber rings using scissors and then remove the rubber ring. All rubber rings are removed in the same way.

 NOTE

Remove a rubber ring strictly based on the cable diameter range and ensure that the crimping module is not damaged. Otherwise, the IP rating of the device will be affected.

**Figure 5-11** Removing a rubber ring

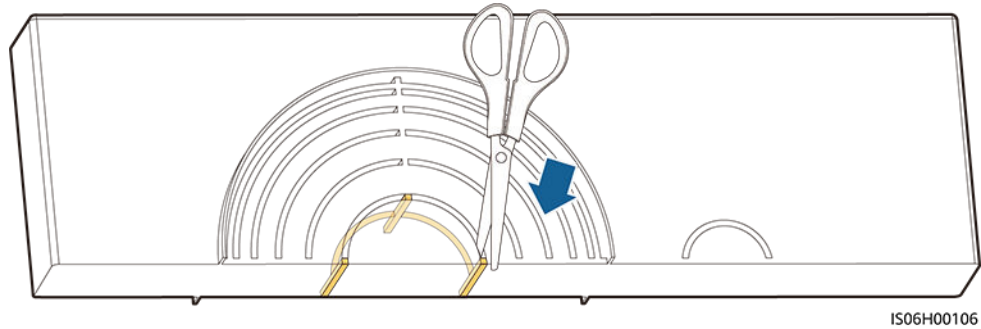

**Step 3** Connect the AC power cables to the terminal block and ensure that the cables are securely connected.

 NOTE

The cable colors shown in the figures are for reference only. Select an appropriate cable according to the local standards.

**Figure 5-12** Single-core cable connection

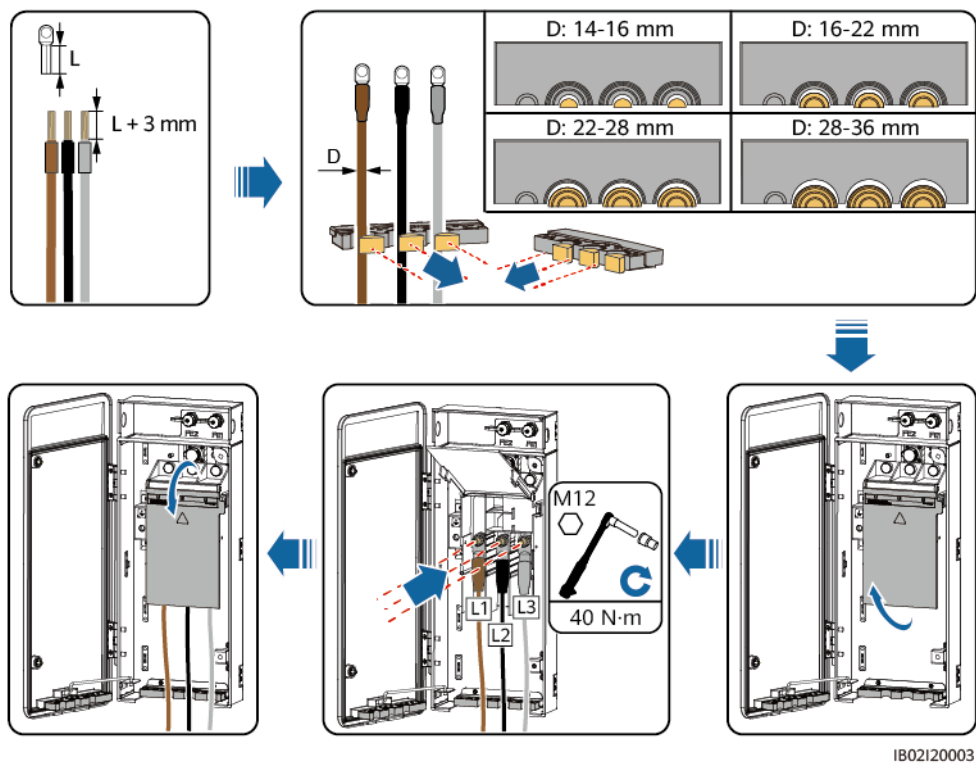

**Figure 5-13** Multi-core cable connection

**NOTE**

It is recommended that the stripped length of the L2 wire be 15 mm shorter than that of the L1 or L3 wire.

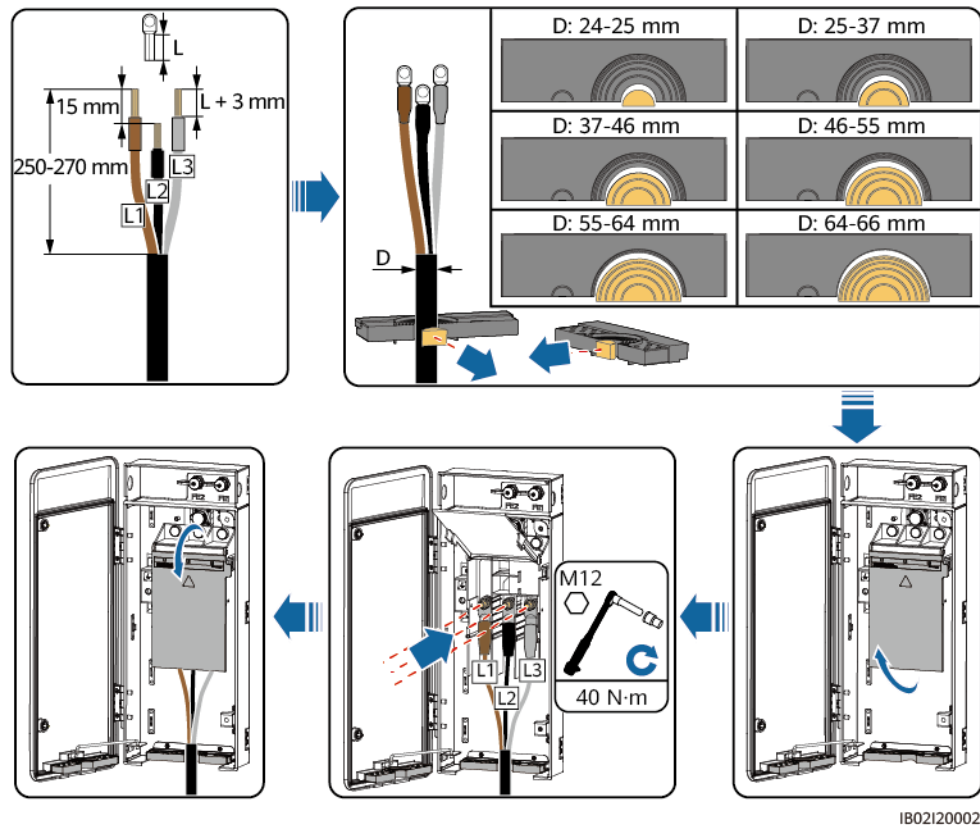

----End

## 5.8 Connecting Communications Cables

**NOTICE**

- If multiple Smart PCSs are used, connect all Smart PCSs into a ring network in hand-in-hand mode through FE communications cables.
- The FE communications cables delivered with the Smart PCS are 1.2 m long. Use the original cables if possible.
- For parallel communication between multiple Smart PCSs, connect all the Smart PCSs in hand-in-hand mode via COM ports.

## Communications Ports

Figure 5-14 Port description

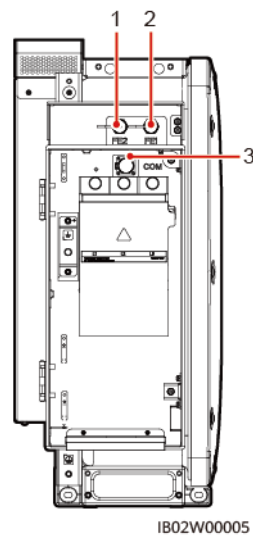

- (1) Network port 2 (FE2) (2) Network port 1 (FE1) (3) Communications port (COM)

### 5.8.1 Connecting FE Communications Cables

- If the SmartACU2000D-D-06 is used, connect the Smart PCSs to the SmartACU through FE communications cables. Ensure that the two ends are connected to G2–G7 of the SmartACU (SWITCH02). A maximum of three ring networks are supported.
- If the SmartACU2000D-D-00, SmartACU2000D-D-01, or SmartACU2000D-D-03 is used, connect the Smart PCSs to the SmartModule through FE communications cables. Ensure that the two ends are connected to GE2 and GE3 of the SmartModule. A maximum of one ring network is supported.

#### NOTE

The SmartACU2000D-D-00 and SmartACU2000D-D-01 can be configured with the SmartModule optionally. The SmartACU2000D-D-03 is configured with the SmartModule by default.

Figure 5-15 Connecting FE communications cables (to the SmartACU2000D-D-06)

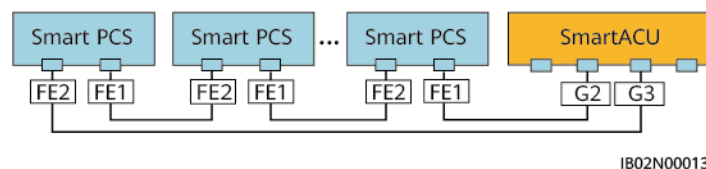

IB02N00013

**Figure 5-16** Connecting FE communications cables (to the SmartACU2000D-D-00, SmartACU2000D-D-01, or SmartACU2000D-D-03)

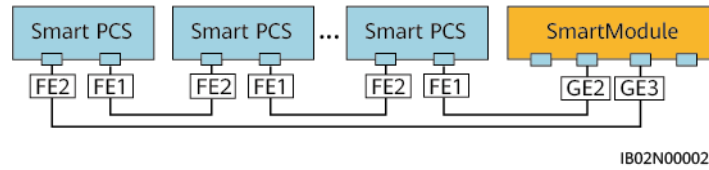

## Procedure

- Step 1** Remove an appropriate length of the insulation layer from the shielded network cable using a wire stripper.
- Step 2** Insert the shielded network cable through the sealing nut, sealing ring, coupling nut, and plastic housing in sequence.

**Figure 5-17** Waterproof RJ45 connector composition

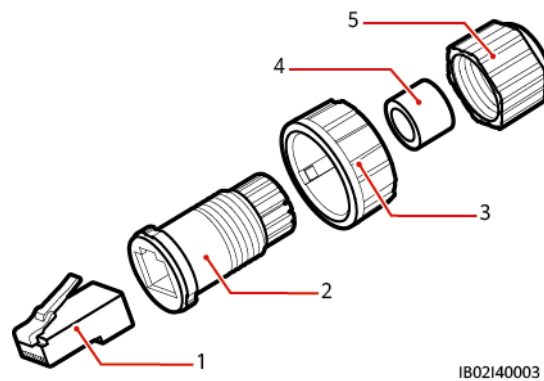

- |                   |                     |                  |
|-------------------|---------------------|------------------|
| (1) Shielded plug | (2) Plastic housing | (3) Coupling nut |
| (4) Sealing ring  | (5) Sealing nut     | -                |

- Step 3** Line up the exposed wires of the shielded network cable in sequence and connect them to the corresponding pins in the plug.

**Figure 5-18** Connecting a plug

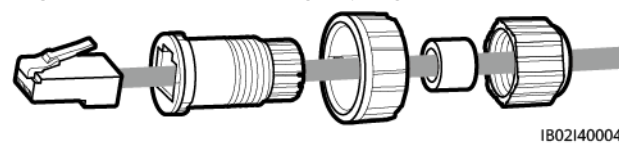

- Step 4** Crimp the plug using a crimping tool.
- Step 5** Secure the plastic housing to the plug.

**Figure 5-19** Connecting a plastic housing

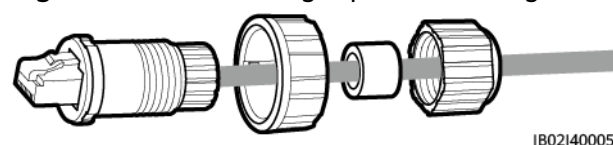

**Step 6** Insert the sealing ring into the plastic housing and secure the coupling nut to the plastic housing.

**Figure 5-20** Connecting a sealing ring and a coupling nut

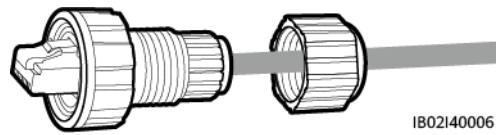

**Step 7** Secure the sealing nut to the plastic housing.

**Figure 5-21** Connecting a sealing nut

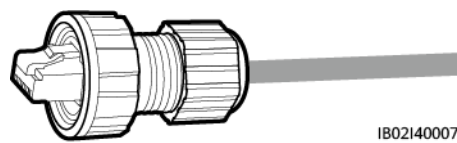

**NOTICE**

Ensure that the sealing nut is secured.

**Step 8** Insert the plugs into the FE ports on the Smart PCS and tighten the coupling nuts.

**Figure 5-22** Connecting the FE communications cables

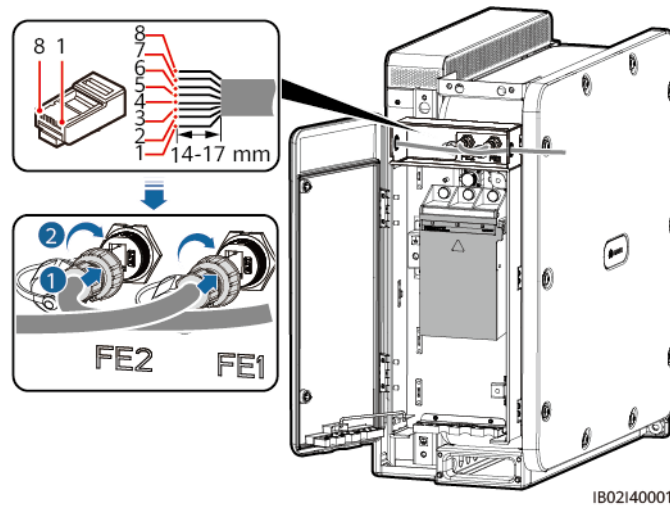

- |                      |            |                     |           |
|----------------------|------------|---------------------|-----------|
| (1) White-and-orange | (2) Orange | (3) White-and-green | (4) Blue  |
| (5) White-and-blue   | (6) Green  | (7) White-and-brown | (8) Brown |

**Step 9** When multiple Smart PCSs are connected in parallel, bind the FE communications cables connecting to the SmartACU or SmartModule at proper positions near the ports.

If Smart PCSs are installed on the DCBOX, bind the cables as shown in the following figure.

**Figure 5-23** Binding FE communications cables

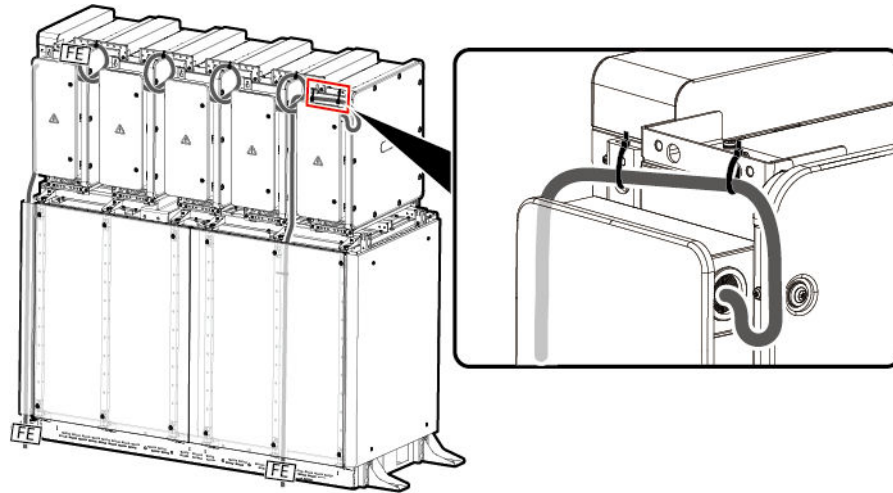

500002

----End

## 5.9 Closing the Maintenance Compartment Door

### Precautions

---

#### NOTICE

- Before closing a maintenance compartment door, check that the cables are connected correctly and securely, close the terminal block cover, and remove any foreign object from the maintenance compartment.
  - If a screw on the maintenance compartment door is lost, obtain a spare screw from the accessory bag in the maintenance compartment.
- 

### 5.9.1 Closing the DC Maintenance Compartment Door

- Step 1** Adjust the support bar, close the maintenance compartment door, and tighten the two screws on the door.

Figure 5-24 Closing the DC maintenance compartment door

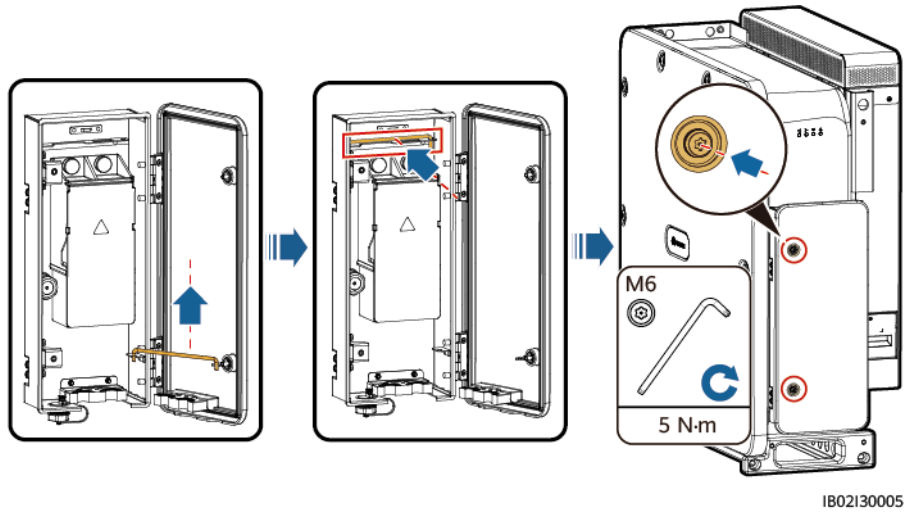

----End

## 5.9.2 Closing the AC Maintenance Compartment Door

- Step 1** Adjust the support bar, close the maintenance compartment door, and tighten the two screws on the door.

Figure 5-25 Closing the AC maintenance compartment door

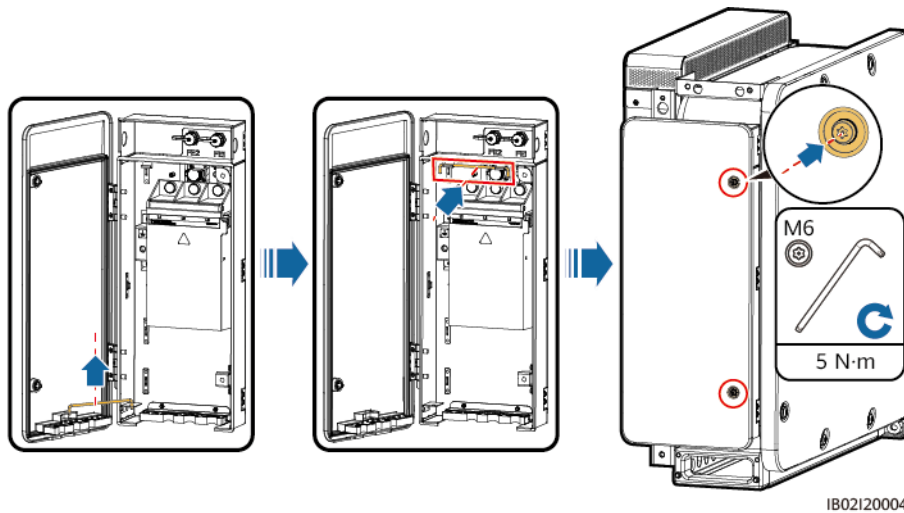

----End

# 6 Checking Before Power-On

Check the items listed in the following table. In case of any nonconforming items, rectify the fault and reinstall the parts. Then check the items in the table again until all they all pass the check.

**Table 6-1** Item

Check Item	Expected Result
Installation checks	The Smart PCS is not deformed or damaged.
	The Smart PCS is properly installed.
	The clearance around the Smart PCS meets requirements.
Electrical connection checks	The external switches on the AC and DC sides are in the OFF position.
	All cables are intact and free from any damage or cracks.
	All ground cables are connected securely and reliably.
	All AC power cables are connected correctly and securely, and no open circuits or short circuits occur.
	All DC cables are connected securely in correct polarity, and no open circuits or short circuits occur.
	The communications cables are connected correctly and securely.
Other check items	The crimping module is securely installed.
	The AC maintenance compartment is clean and tidy.
	The DC maintenance compartment is clean and tidy.
	The AC maintenance compartment door is closed and the screws on the door are tightened.
	The DC maintenance compartment door is closed and the screws on the door are tightened.

Check Item	Expected Result
	The waterproof plugs on the unused USB, COM, and FE ports are secured.

# 7 Power-On and Commissioning

---

- The Smart PCS can be commissioned on the SmartLogger WebUI or SUN2000 app. The SmartLogger can manage multiple devices. For details, see the [SmartLogger3000 User Manual](#). The app is used for local commissioning, mainly to modify the parameters and upgrade the software version of a single Smart PCS.
- Perform deployment and commissioning for the Smart PCS and ESS together. For details, see the [LUNA2000-2.0MWH and 1.0MWH Series Smart String ESS User Manual](#).

## 7.1 Powering on the Smart PCS

### Precautions

Ensure that all the items in [6 Checking Before Power-On](#) are checked and meet the requirements before power-on.

---

#### DANGER

- Wear personal protective equipment and use dedicated insulated tools to avoid electric shocks or short circuits.
- 

---

#### NOTICE

- Before turning on the AC switch between the Smart PCS and the power grid, check whether the AC voltage is within the allowed range using a multimeter. (See the local power grid standard.)
  - Before the equipment is put into operation for the first time, ensure that the parameters are set correctly by professional personnel. Incorrect parameter settings may result in noncompliance with local grid connection requirements and affect the normal operations of the equipment.
  - If the Smart PCS has not been used for six months or longer after being installed, it must be checked and tested by professionals before operation.
-

## 7.1.1 On-Grid Power-On

### Procedure

- Step 1** Turn on the AC switch between the AC side of the Smart PCS and the power grid.
- Step 2** Ensure that the DC side of the Smart PCS is properly connected to the ESS output.
- Step 3** Send a startup command on the SUN2000 app, SmartLogger, or management system, and wait for the system soft start.

 **NOTE**

Before sending a startup command to the Smart PCS, ensure that the DC voltage is within the normal range.

- Step 4** Observe the LED indicators to check the running status of the Smart PCS.

----End

## 7.1.2 Off-Grid Power-On

For details about how to power on a medium-voltage microgrid system, see the *Medium-Voltage Microgrid Energy Storage Solution Quick Guide*.

### Prerequisites

- When there is no power supply from the power grid, turn off the high-voltage side of the transformer station.
- Check that the A/B/C phase sequence of the cable between the Smart PCS and the low-voltage side of the transformer station is correct. The Smart PCSs for the same ESS must be connected to the same low-voltage power distribution system of the transformer station (in the double-split transformer scenario).
- The SACU and the CMU in the ESS are powered by the UPS.
- The SACU and the CMU in the ESS have been networked.

### Procedure

- Step 1** Ensure that the DC side of the Smart PCS is properly connected to the ESS output.
- Step 2** Turn on the AC switch between the AC side of the Smart PCS and the transformer station.
- Step 3** Send a startup command on the SUN2000 app, SmartLogger, or management system, and wait for the system soft start.

 **NOTE**

Before sending a startup command to the Smart PCS, ensure that the DC voltage is within the normal range.

- Step 4** Observe the LED indicators to check the running status of the Smart PCS.

----End

## 7.1.3 Commissioning the Smart PCS Using the App

### 7.1.3.1 Downloading the App

#### App Functions

The SUN2000 app (also referred to as the app) is a convenient local maintenance platform that connects to the Smart PCS through WLAN and allows users to query alarms, configure parameters, and perform routine maintenance.

The Smart PCS can be commissioned using the SmartLogger or app. For details about how to commission the SmartLogger, see the [SmartLogger3000 User Manual](#). The app is used for local commissioning, mainly to modify the parameters and upgrade the software version of a single Smart PCS.

#### Downloading the App

Access Huawei AppGallery, search for **SUN2000**, and download the app. Alternatively, scan the following QR codes to download the app installation package.

QR codes:



Android



iOS

#### Connecting the Smart PCS to the App

After the DC or AC side of the Smart PCS is powered on, the app can connect to the Smart PCS through the WLAN module.

---

#### NOTICE

- The USB-Adapter2000-C WLAN module is supported.
  - The mobile phone operating system must be Android 5.0 or later.
-

Figure 7-1 WLAN module connection

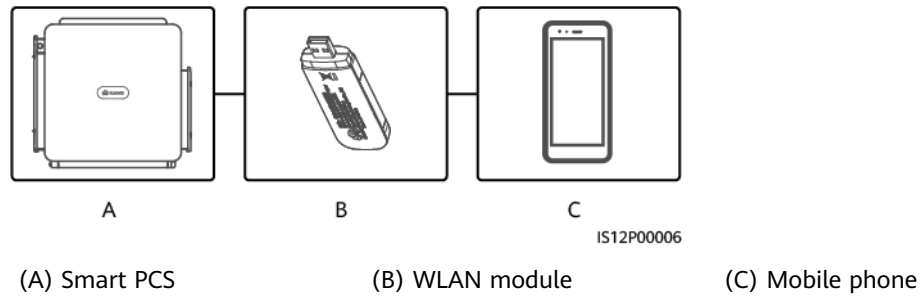

#### NOTICE

- If the AC switch between the Smart PCS and the power grid is turned on, but the external switch on the DC side of the Smart PCS is turned off, some parameters cannot be set. Turn on the external switch on the DC side, and then reconfigure the parameters.
- Changing the grid code will restore some parameters to factory defaults. After the grid code is changed, check whether the previously set parameters are affected.
- Sending a reset, shutdown, or upgrade command to the Smart PCS may interrupt its operation.
- When the Smart PCS is powered on for the first time, ensure that the parameters are set correctly by professionals. Incorrect parameter settings may result in noncompliance with local requirements and affect the normal operations of the Smart PCS.
- Only professionals are allowed to set the grid, protection, feature, and power adjustment parameters of the Smart PCS. If the grid, protection, and feature parameters are set incorrectly, the Smart PCS may disconnect from the grid. If the power adjustment parameters are set incorrectly, the Smart PCS may not connect to the power grid as required.

#### NOTE

- Configurable parameters vary depending on the grid code.
- The parameter names, value ranges, and default values are subject to change. The actual display may vary.

### 7.1.3.2 Logging In to the App

#### Prerequisites

- The DC or AC side of the Smart PCS has been powered on.
- When connecting through a WLAN module:
  - a. The WLAN module has been inserted into the **USB** port at the bottom of the Smart PCS.
  - b. The WLAN function has been enabled on your phone.
  - c. Keep the mobile phone within 5 m from the Smart PCS. Otherwise, the communication between them might be affected.

## Procedure

**Step 1** In the SUN2000 app, select a connection mode.

### NOTE

- The screenshots in this section correspond to the SUN2000 app 6.23.00.125 (Android).
- When the WLAN connection is used, scan the QR code of the WLAN module to access the login screen.
- When the WLAN connection is used, the initial name of the WLAN hotspot is **Adapter-WLAN module SN** and the initial password is **Changeme**. Use the initial password for the first login and change it immediately after login. To ensure account security, protect the password by changing it periodically, and keep it secure. Your password might be stolen or cracked if it is left unchanged for extended periods. If a password is lost, devices cannot be accessed. In these cases, the Company shall not be liable for any loss caused to the plant.

**Figure 7-2** Selecting a connection mode

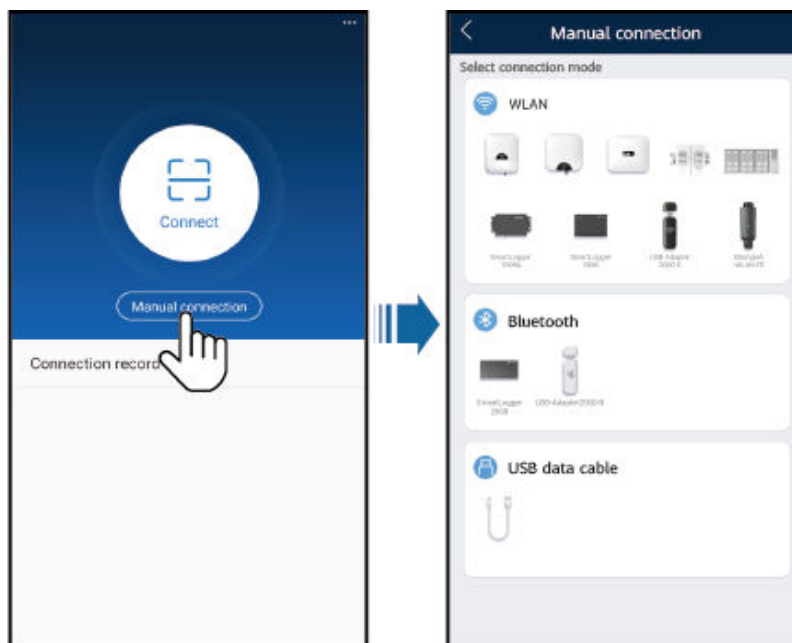

**Step 2** Select the login user and enter the login password. The main menu screen is displayed.

### NOTICE

- When you log in to the system for the first time, set the login password. To ensure account security, protect the password by changing it periodically, and keep it secure. Your password might be stolen or cracked if it is left unchanged for extended periods. If a password is lost, devices cannot be accessed. In these cases, the Company shall not be liable for any loss caused to the plant.
- You will be locked out for 10 minutes after five consecutive failed password attempts at an interval of less than 2 minutes.

Figure 7-3 Login

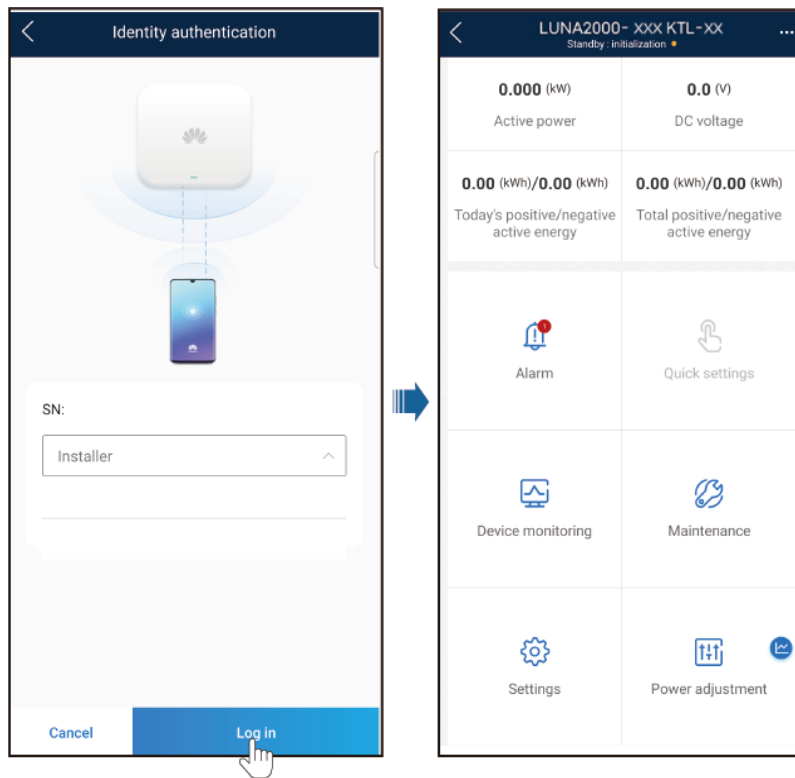

**NOTE**

Set the correct grid code based on the application area and scenario of the Smart PCS.

----End

# 8 Device Maintenance

---

## 8.1 Routine Maintenance

### Precautions

---

** DANGER**

- Wear personal protective equipment and use dedicated insulated tools to avoid electric shocks or short circuits.
- 

---

** WARNING**

- Before performing maintenance, power off the equipment, follow the instructions on the delayed discharge label, and wait for a period of time as specified to ensure that the equipment is not energized.
- 

---

** CAUTION**

When cleaning the system, connecting cables, and checking grounding reliability, power off the system and ensure that the external switches on the DC and AC sides are turned off.

---

### Maintenance Items

To ensure that the device operates properly for a long term, you are advised to perform routine maintenance as described in this section.

**Table 8-1** Maintenance checklist

Check Item	Check Method	Maintenance Interval
<ul style="list-style-type: none"> <li>• Cleanness of the air intake vent</li> <li>• Cleanness of the air exhaust vent</li> <li>• Fan</li> </ul>	<ul style="list-style-type: none"> <li>• Check whether there is dust on the air intake and exhaust vents. If necessary, remove and clean the baffle plates.</li> <li>• Check whether the fans generate abnormal noise during operation.</li> </ul>	Once every 6 to 12 months
System status	<ul style="list-style-type: none"> <li>• Check whether the enclosure is damaged or deformed.</li> <li>• Check whether the device generates abnormal sounds during operation.</li> <li>• Check whether the parameters are correctly set during operation.</li> </ul>	Once every 6 months
Cable connection	<ul style="list-style-type: none"> <li>• Check whether cables are disconnected or loose.</li> <li>• Check whether cables are damaged, especially whether the cable sheath that contacts a metal surface is damaged.</li> <li>• Check whether the unused COM, USB, and FE ports are locked by waterproof caps.</li> </ul>	6 months after the first commissioning and once every 6 to 12 months after that
Grounding reliability	Check whether the ground cables are securely grounded.	6 months after the first commissioning and once every 6 to 12 months after that

## Removing the Baffle Plate from the Air Intake Vent

**Figure 8-1** Removing the baffle plate

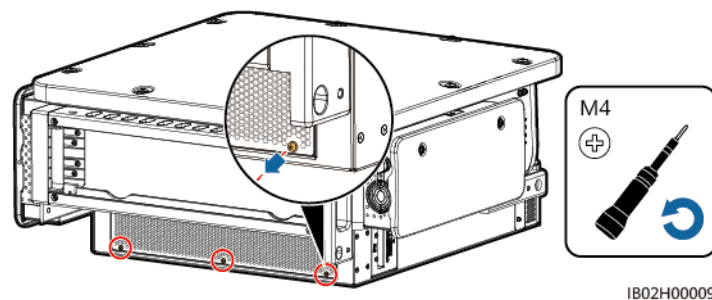

**NOTICE**

After the cleaning is complete, reinstall the baffle plate to the air intake vent. Tighten the screws with a torque of 1.2 N·m.

## Removing the Protective Cover from the Air Exhaust Vent

Figure 8-2 Removing the protective cover

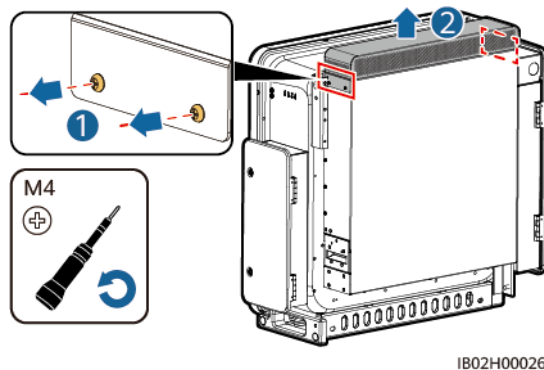

**NOTICE**

After the cleaning is complete, reinstall the protective cover to the air exhaust vent. Tighten the screws with a torque of 1.2 N·m.

## 8.2 Powering Off the System

### Precautions

To prevent personal injury and equipment damage, perform the following procedure to power off the Smart PCS for troubleshooting or replacement.

**CAUTION**

- If the DC switch between the Smart PCS and the DC LV Panel busbar has been turned off automatically, do not turn on the switch before the fault is rectified.
- If the AC switch between the Smart PCS and the power grid has been turned off automatically, do not turn it on before the fault is rectified.
- Before power-off for maintenance, do not touch the energized components of the Smart PCS. Otherwise, electric shocks or arcs may occur.

### Procedure

**Step 1** Wear proper PPE.

- Step 2** Send a shutdown command on the SUN2000 app, SmartLogger, or management system.
- Step 3** Turn off the AC switch between the Smart PCS and the power grid or load.
- Step 4** Open the AC maintenance compartment door, install a support bar, and use a multimeter to check the voltage between the AC terminal block and the ground. Ensure that the AC side of the Smart PCS is powered off.
- Step 5** Turn off the DC switch between the Smart PCS and the DC LV Panel busbar.
- Step 6** Open the DC maintenance compartment door, install a support bar, and use a multimeter to check the voltage between DC terminal blocks. Ensure that the DC side of the Smart PCS is powered off.
- Step 7** Wait for 15 minutes and troubleshoot or repair the Smart PCS.

**Figure 8-3** Power-off for maintenance

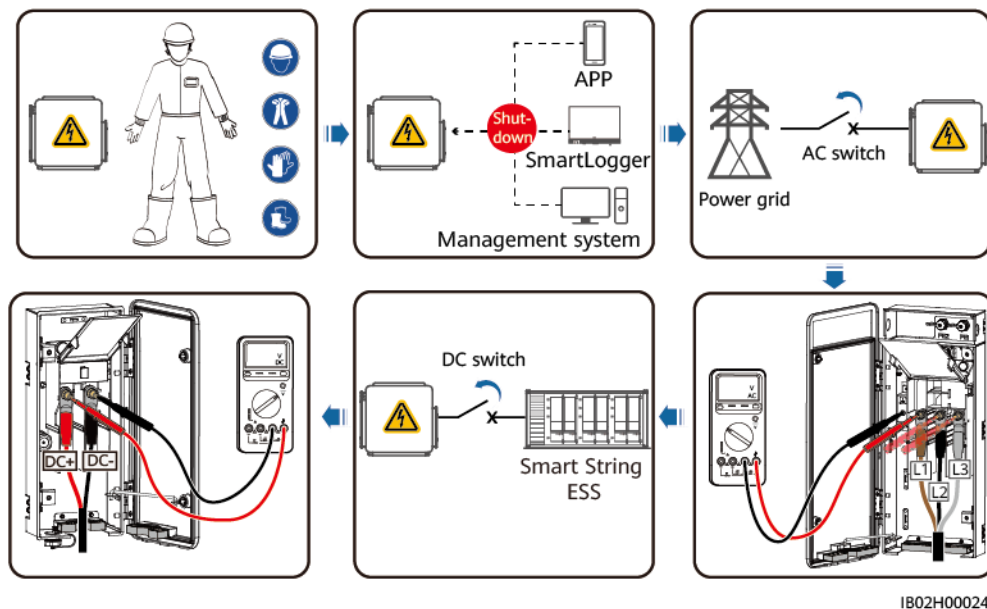

**⚠ WARNING**

- Do not open the panel for maintenance if the Smart PCS is emitting abnormal smell or smoke, or has obvious exceptions.
- If the Smart PCS does not emit abnormal smell or smoke and is intact, repair or restart it based on the alarm handling suggestions.

----End

## 8.3 Alarm Reference

For details about alarms, see the [LUNA2000-100KTL and 200KTL Series Smart Power Control System Alarm Reference](#).

## 8.4 Replacing a Fan

### Precautions

**CAUTION**

- Before replacing a fan, power off the Smart PCS.
- When replacing a fan, use insulated tools and wear PPE.

**NOTE**

If the fan gets stuck when being pulled or pushed, slightly lift it.

### Procedure

- Step 1** Remove the screws from the fan tray and store them properly. Pull out the fan tray until the fan tray is flush with the Smart PCS.

**Figure 8-4** Pulling out the fan tray (1)

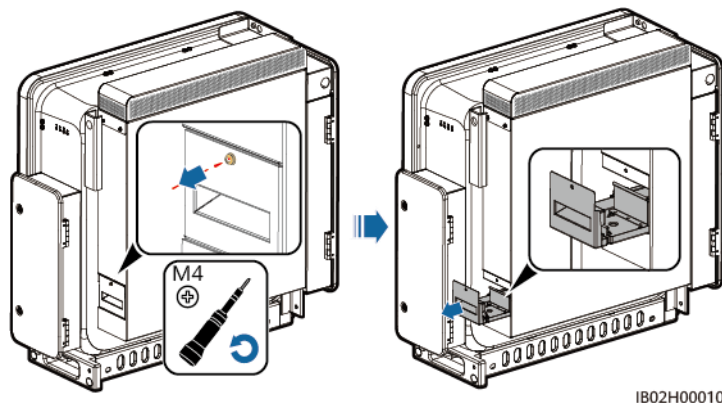

- Step 2** Remove the cable ties shared by the cables, unscrew the connectors, and disconnect the cables.

**Figure 8-5** Disconnecting cables

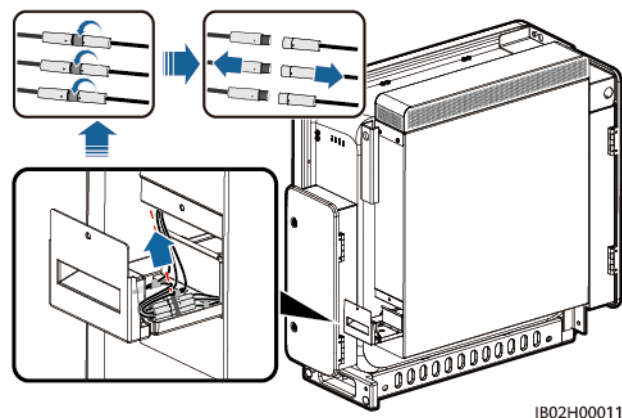

**Step 3** Pull out the fan tray completely.

**Figure 8-6** Pulling out the fan tray (2)

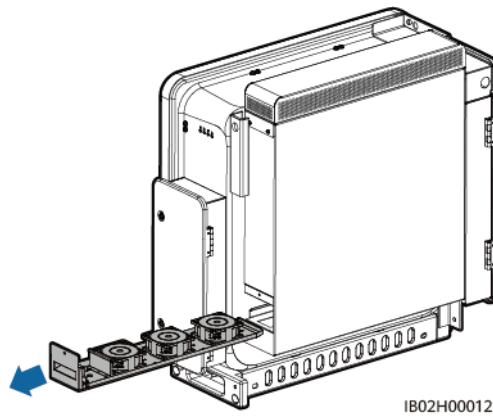

**Step 4** Remove cable ties of the faulty fan.

- FAN 1 is faulty.

**Figure 8-7** Removing cable ties from FAN 1

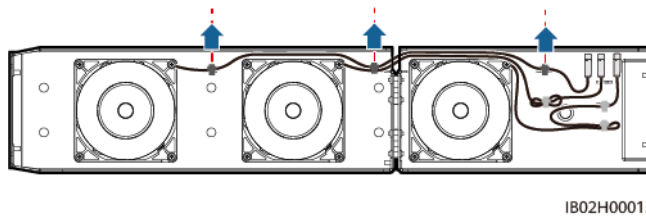

- FAN 2 is faulty.

**Figure 8-8** Removing cable ties from FAN 2

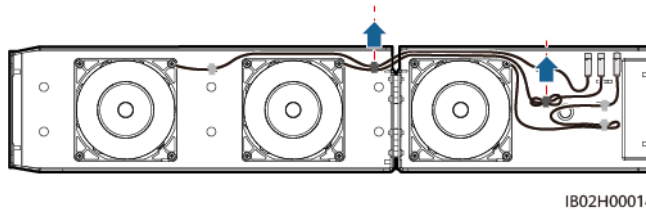

- FAN 3 is faulty.

**Figure 8-9** Removing cable ties from FAN 3

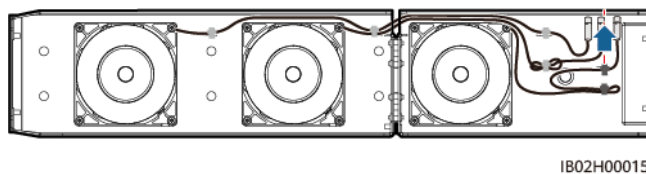

**Step 5** Remove the faulty fan (FAN 1 is used as an example).

**Figure 8-10** Removing the fan

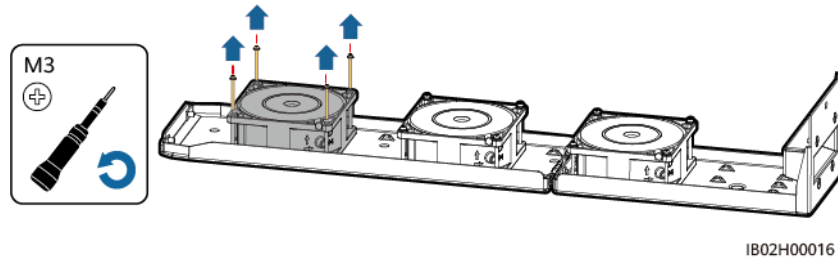

**Step 6** Install a new fan (FAN 1 is used as an example).

**Figure 8-11** Installing a fan

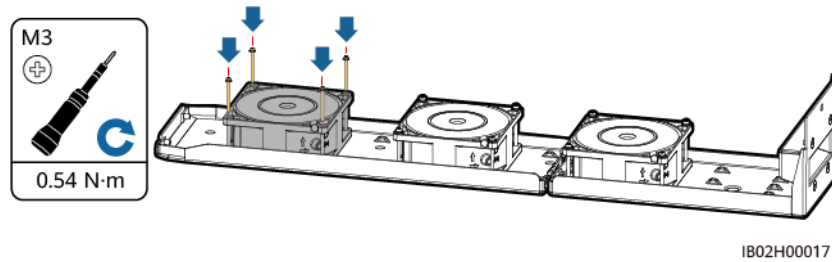

**Step 7** Bind the fan cables.

- Binding positions for FAN 1

**Figure 8-12** Binding the cables of FAN 1

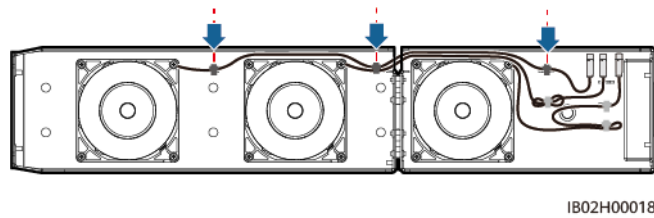

- Binding positions for FAN 2

**Figure 8-13** Binding the cables of FAN 2

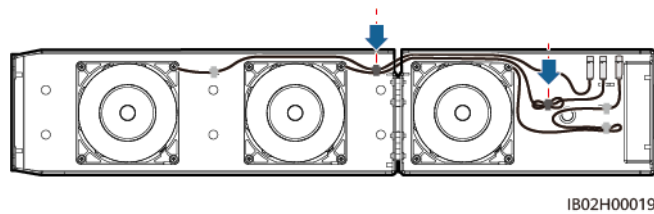

- Binding positions for FAN 3

**Figure 8-14** Binding the cables of FAN 3

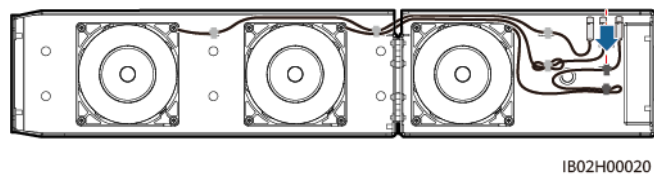

**Step 8** Push in the fan tray until the fan baffle plate is flush with the Smart PCS.

**Figure 8-15** Pushing in the fan tray

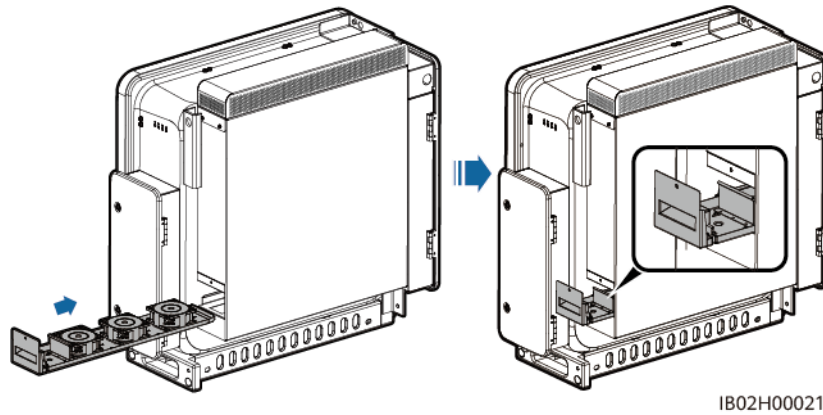

**Step 9** Connect the cables correctly according to the cable labels and bind the cables.

**Figure 8-16** Binding cables

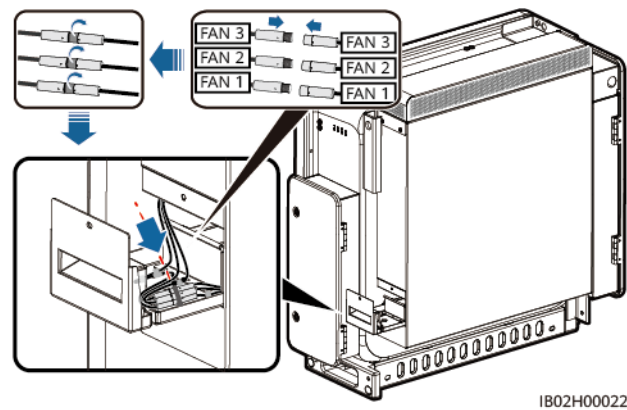

**Step 10** Push in the fan tray completely and tighten the screws.

**Figure 8-17** Reinstalling the fan tray

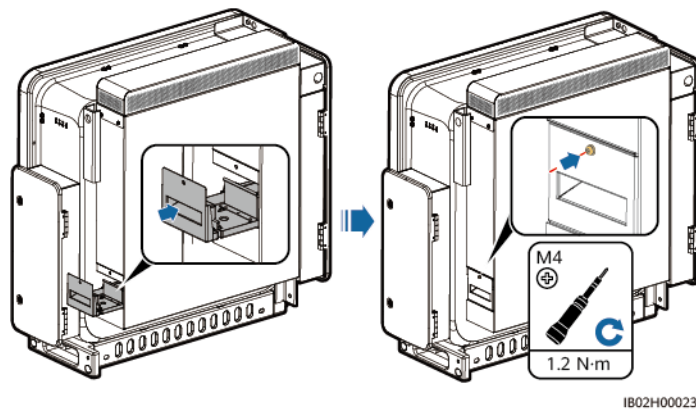

----End

## 8.5 Replacing the Smart PCS

### Context

The device enclosure is severely damaged or the device hardware is faulty due to external forces.

### Procedure

- Step 1** Send a shutdown command on the SUN2000 app, SmartLogger, or management system.
- Step 2** Turn off the external switches on the DC and AC sides.
- Step 3** Remove the DC power cables, AC power cables, communications cables, and PE cable from the Smart PCS in sequence.
- Step 4** Remove the Smart PCS based on site requirements.
  1. Support-mounted or wall-mounted

**Figure 8-18** Removing the Smart PCS

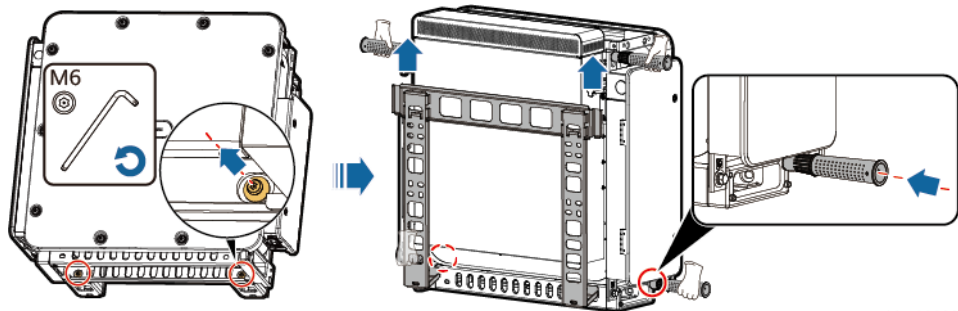

2. Installed on the DCBOX

**Figure 8-19** Removing screws from the Smart PCS

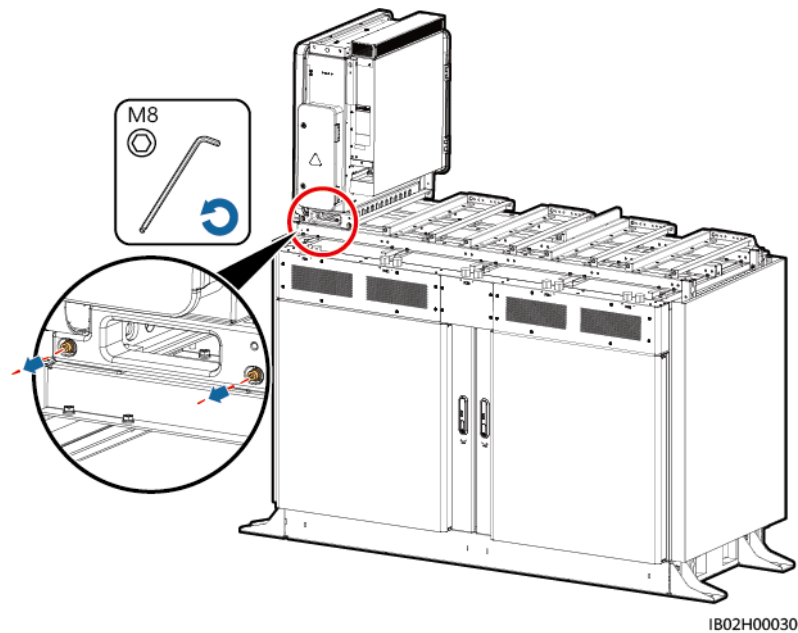

**Figure 8-20** Removing the Smart PCS

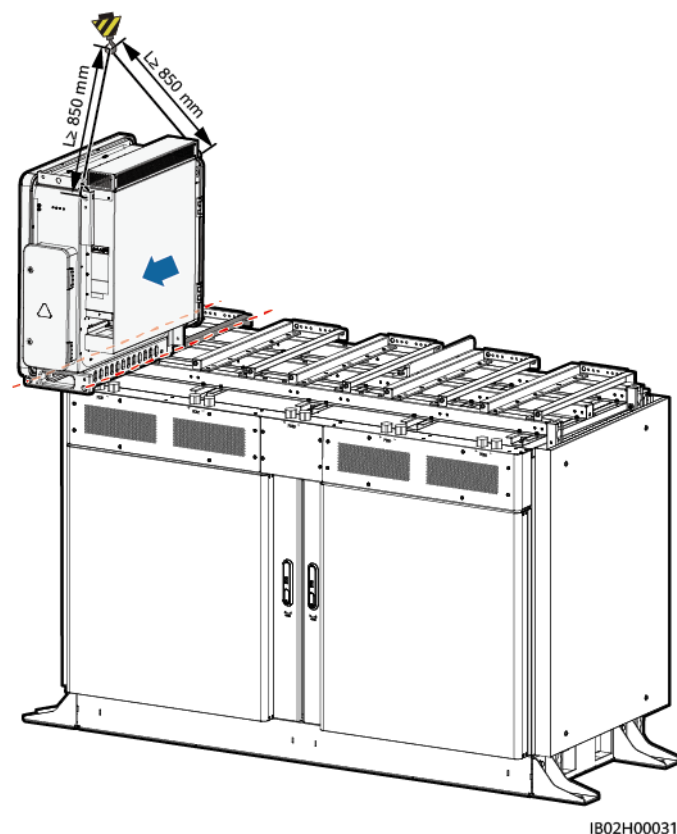

**Step 5** Install the new Smart PCS.

**Step 6** Connect the PE cable, DC power cables, AC power cables, and communications cables in sequence. For details, see [5 Cable Connection](#).

**Step 7** Power on the Smart PCS. Observe the LED indicators to check the running status of the Smart PCS and verify that the replacement is successful.

----End

## Follow-up Procedure

**Step 1** Log in to the SmartLogger WebUI, choose **Maintenance > Connect Device**, select the ESS, and click  to send a startup command. Observe LED indicators of the Smart PCS and ensure that the DC side of the Smart PCS is powered on.

**Step 2** Upgrade software of the new Smart PCS. Ensure that the software version of the new Smart PCS is the same as that of other Smart PCSs on site.

**Step 3** Choose **Monitoring > Running Param. > Grid Parameters**, and set **Grid code**. Ensure that the grid code setting of the new Smart PCS matches the local grid code. Wait for 10s, and then go to step 4.

**Step 4** The settings of **Grid Parameters, Protection Parameters, Feature Parameters, Power Adjustment, and Power Baseline** of the new device must be synchronized from other devices. This section uses **Grid Parameters** settings as an example to describe how to synchronize data. The operations for setting other parameters are similar.

Click **Monitoring**, select a running device, choose **Running Param. > Grid Parameters > All > Batch configurations**, and click **Confirm** to synchronize data to the new device.

Figure 8-21 Setting running parameters

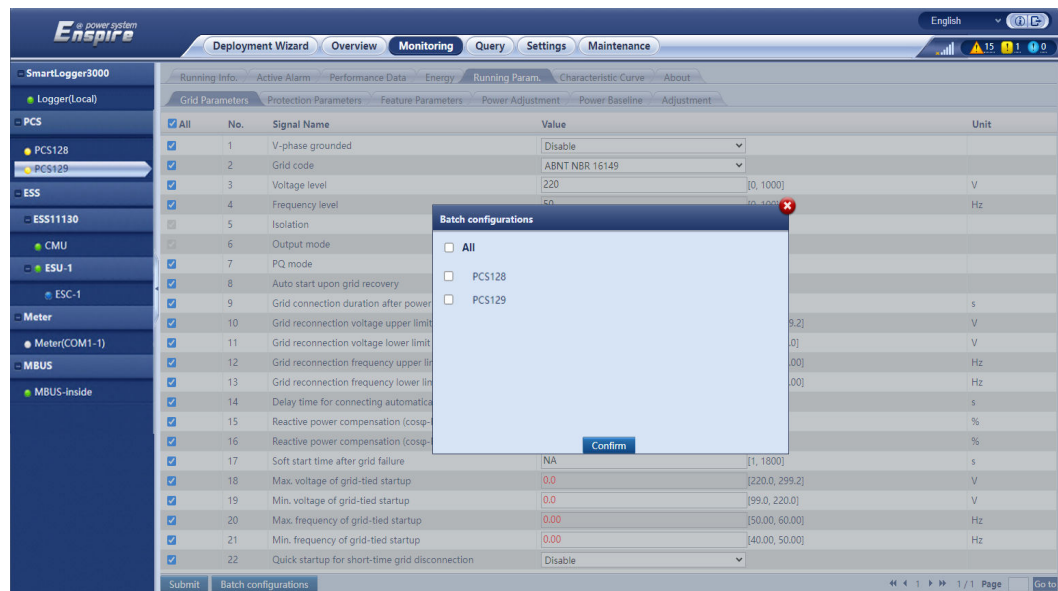

**Step 5** Click **Monitoring**.

1. Select the faulty Smart PCS, choose **Running Param. > Adjustment**, and record the values of **Adjust total energy yield** and **Calibration of total power supply from grid**.

2. Select the new device, choose **Running Param. > Adjustment**, and set **Adjust total energy yield** and **Calibration of total power supply from grid** to be the same as those of the original device.

**Figure 8-22** Energy yield calibration

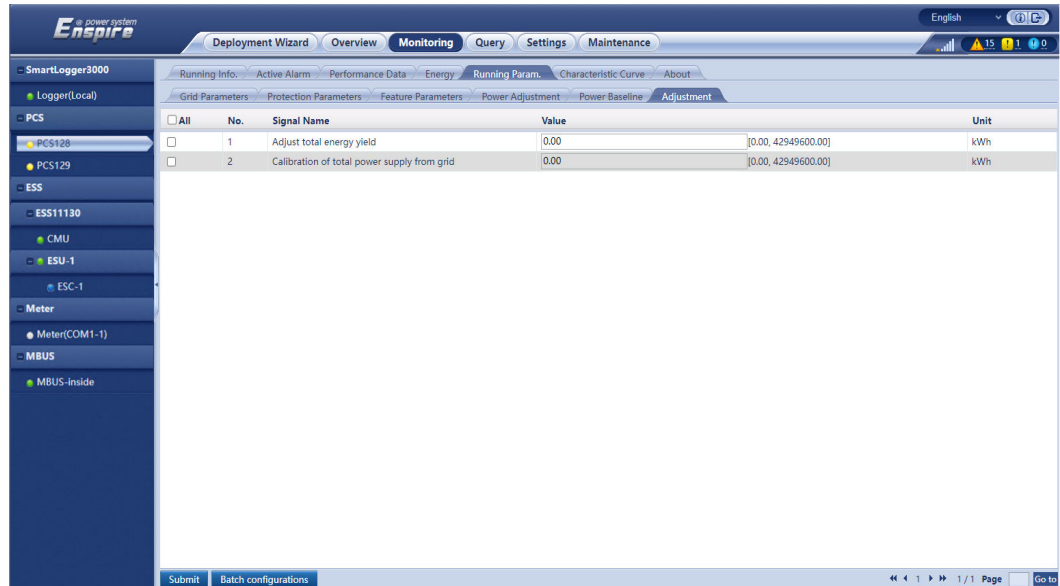

**Step 6** (Optional) If a third-party NMS that complies with the IEC 104 protocol is connected, choose **Settings > IEC104**, and ensure that the teleindication, telemetry, telecontrol, and teleadjust signal numbers of the new Smart PCS on all tab pages under IEC104 are the same as those of the faulty Smart PCS.

**Step 7** Identify the topology.

- For SmartLogger V300R023C10 and later versions, enter the SNs of the old and new devices and click **Submit**. The devices in the topology are automatically updated.

Figure 8-23 Replacing devices

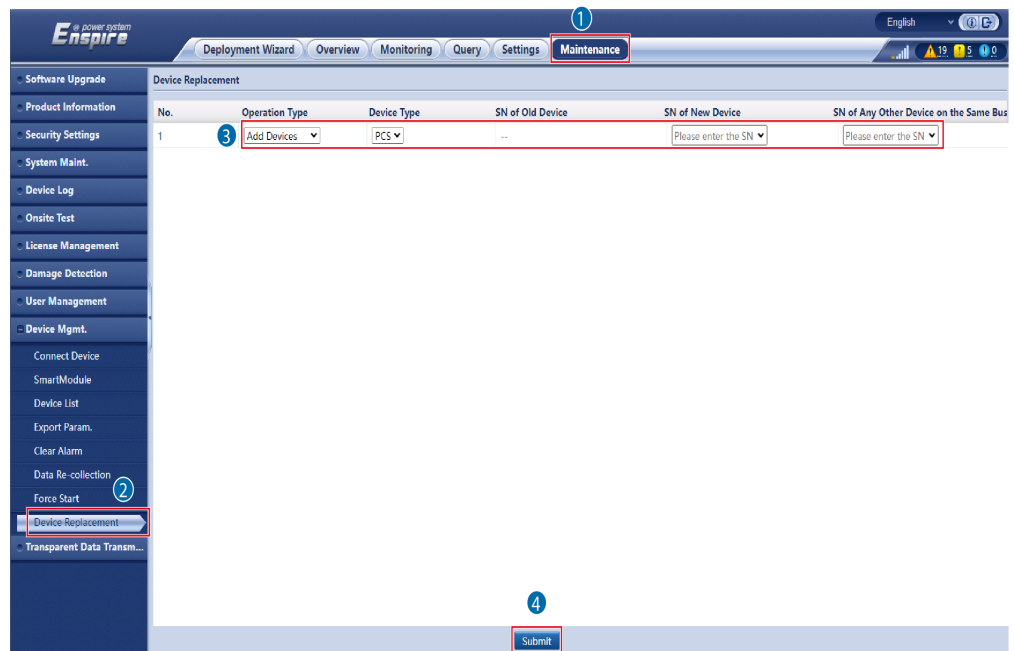

- For versions earlier than SmartLogger V300R023C10, go to **Deployment Wizard** and click **Search for Device** to check cable connections and allocate addresses.

Figure 8-24 Searching for devices

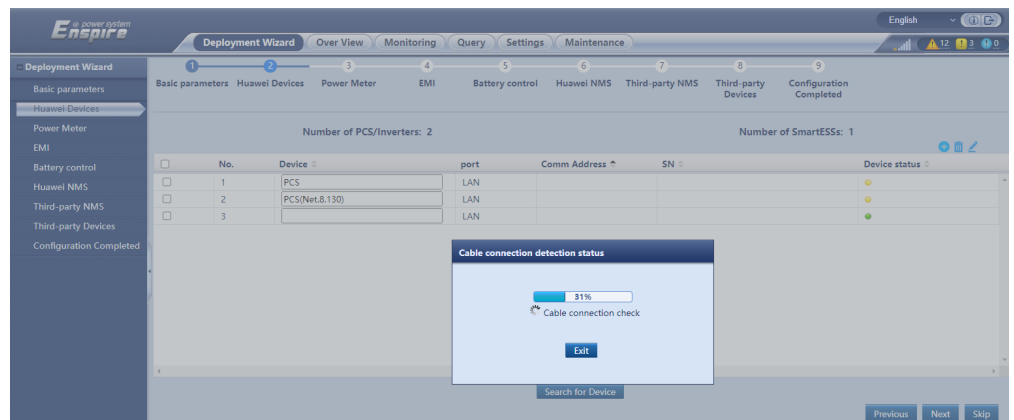

**NOTE**

- During the process of **Search for Device**, do not perform upgrade operations (such as upgrading through the app, management system, or WebUI).
- When you click **Search for Device**, cable connections (DC and AC) will be checked before device search (not applicable to third-party devices), and device addresses will be automatically allocated.
- After the cable connection check and device search are complete, if a cable connection alarm is generated, you can click the alarm icon to view the corresponding alarm information.
- If an alarm is generated when the cable connection check fails, click the alarm icon to view the alarm cause and handling suggestions. After the fault is rectified, check the cable connections again.
- After the cable connection check and device search are complete, click to view the corresponding topology information.
- After a device is added or deleted, you need to click **Search for Device** again in **Deployment Wizard**. Otherwise, the system topology will not be updated.

**Step 8** Delete the faulty Smart PCS.

Choose **Maintenance > Connect Device**, select the faulty Smart PCS, click **Remove Devices**, and click **Confirm**.

**Figure 8-25** Deleting a device

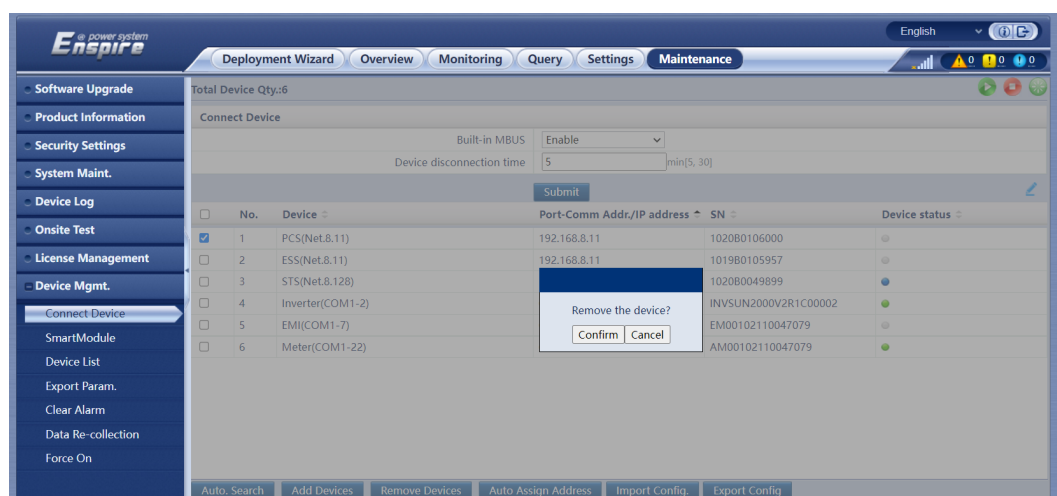

**Step 9** Choose **Maintenance > Connect Device**, select the Smart PCS, and click to send a startup command. After the Smart PCS is started, check that it is running properly.

**Step 10** (Optional) Log in to the PV plant management system, access the plant, choose **Device Management**, select the faulty Smart PCS, click **Delete**, and click **OK**.

**NOTE**

- Perform this step if you purchase and use the PV plant management system.
- The software version corresponding to the user interface (UI) screenshot in this step is iMaster NetEco V600R023C00SPC110. The UI may vary by software versions and the screenshot is for reference only.

**Figure 8-26** Deleting a device

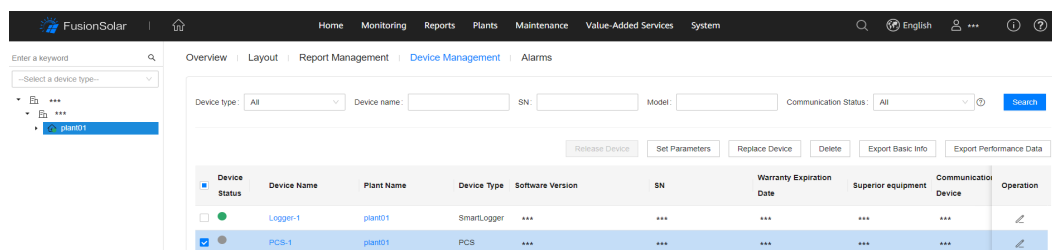

----End

## 8.6 Disposing of the Smart PCS

If the Smart PCS reaches the end of its service life, dispose of the device according to local regulations for the disposal of electrical equipment.

# 9 Technical Specifications

## Efficiency

Item	LUNA2000-200KTL-H1
Maximum efficiency	99.01%

## DC Side

Item	LUNA2000-200KTL-H1
Number of DC routes	1
Maximum DC voltage	1500 V
Maximum DC power	245 kW
Maximum DC current	207.6 A
Minimum startup voltage <sup>[1]</sup>	540 V
Full-load voltage range	1180–1350 V (rectifier mode) 1180–1280 V (inverter mode)
Operating voltage range	1180–1500 V
Rated DC voltage	1180 V
Note [1]: The minimum startup voltage is the minimum startup voltage of the auxiliary power supply inside the device.	

## Protection

Item	LUNA2000-200KTL-H1
Anti-islanding protection	Supported

Item	LUNA2000-200KTL-H1
AC overcurrent protection	Supported
DC reverse connection protection	Supported
DC surge protection	Type II
AC surge protection	Type II
Insulation resistance detection	Supported
Residual current monitoring unit (RCMU)	Supported
Overtoltage category	DC II/AC III

## Display and Communication

Item	LUNA2000-200KTL-H1
Display	LED indicators and WLAN module+app
Ethernet	Supported
USB	Supported

## General Specifications

Item	LUNA2000-200KTL-H1
Dimensions (H x W x D)	820 mm x 875 mm x 365 mm
Net weight	< 99 kg
Operating temperature	-25°C to +60°C (derated at +40°C or higher)
Cooling mode	Smart air cooling
Maximum operating altitude	4000 m (derated when the altitude is greater than 2000 m)
Relative humidity	0%–100% RH
AC/DC terminal	OT/DT terminal
IP rating	IP66
Topology	Transformerless

## On-Grid Parameters

Item	LUNA2000-200KTL-H1
Rated AC voltage	800 V
Rated AC power	200 kW
Maximum apparent power	240 kVA
Maximum active power	240 kW
Rated AC current	144.3 A
Maximum AC current	173.2 A
Supported power grid frequency	50 Hz/60 Hz
Power factor	1 leading and 1 lagging
Maximum total harmonic distortion (rated power)	< 3%

## Off-Grid Parameters

Item	LUNA2000-200KTL-H1
AC output voltage	800 V (line voltage)
DC component in output voltage	±0.1% (with a transformer)
Output frequency	50 Hz/60 Hz
Phase difference (three-phase voltage)	120±1° (balanced load)
Rated output power	200 kW
Voltage THD_linear load	< 1.5% (0.8 leading and 0.8 lagging)
Unbalanced load	100% unbalanced (with a transformer)

# A Crimping an OT or DT Terminal

---

## Requirements for OT/DT terminals

- If a copper cable is used, use copper wiring terminals.
- If a copper-clad aluminum cable is used, use copper wiring terminals.
- If an aluminum alloy cable is used, use copper-to-aluminum wiring terminals, or aluminum wiring terminals with copper-to-aluminum washers.

---

### NOTICE

- Do not connect aluminum wiring terminals directly to the AC or DC terminal block, as this may lead to electrochemical corrosion which affects the reliability of cable connections.
  - Comply with IEC 61238-1 requirements when using copper-to-aluminum wiring terminals, or aluminum wiring terminals with copper-to-aluminum washers.
  - Ensure that the aluminum side of the washer contacts the aluminum wiring terminal, and the copper side contacts the terminal block.
-

**Figure A-1** Requirements for OT/DT terminals

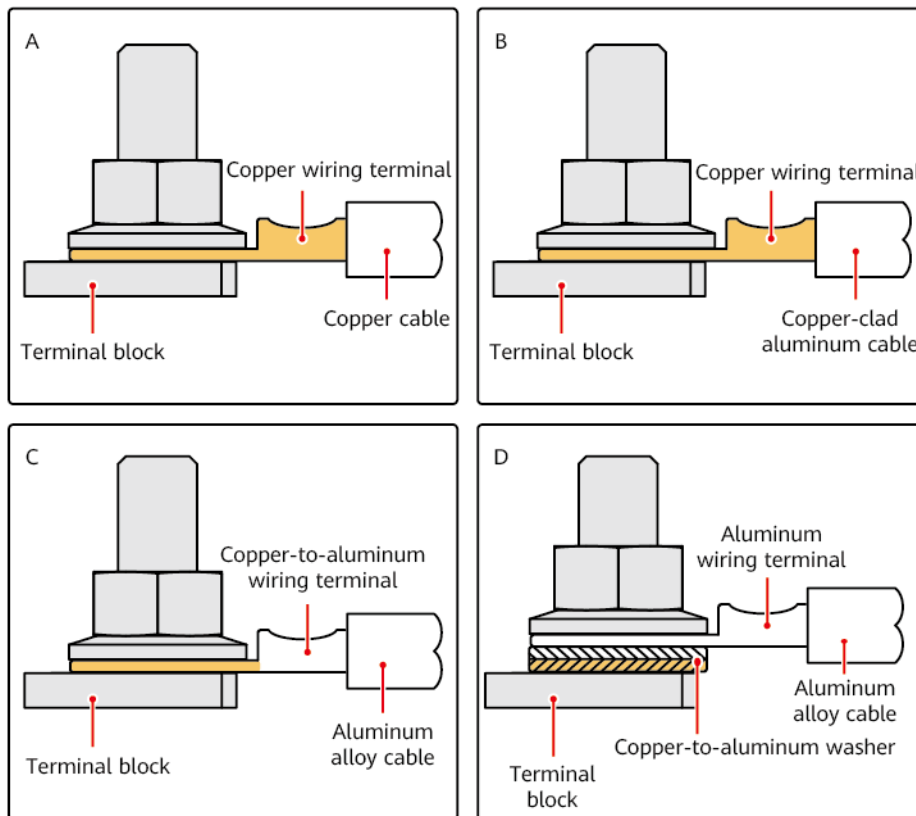

IS03H00062

## Crimping an OT or DT Terminal

### NOTICE

- Avoid scratching the core wire when stripping a cable.
- The cavity formed after the conductor crimp strip of the OT or DT terminal has been crimped must completely wrap around the core wires. In addition, the core wires must be in close contact with the OT or DT terminal.
- Wrap the wire crimping area with heat-shrink tubing or insulation tape. Heat-shrink tubing is used in this section as an example.
- Take care when using a heat gun to avoid heat damage to the equipment.

**Figure A-2** Crimping an OT terminal

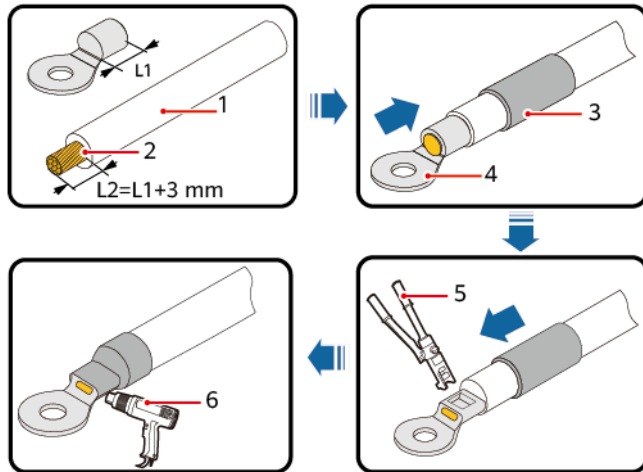

IS06Z00001

- (1) Cable
- (2) Core
- (3) Heat-shrink tubing
- (4) OT terminal
- (5) Hydraulic pliers
- (6) Heat gun

**Figure A-3** Crimping a DT terminal

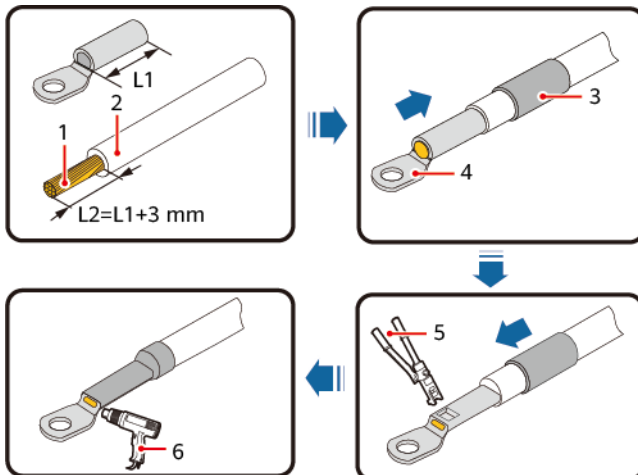

IS06Z00002

- (1) Cable
- (2) Core
- (3) Heat-shrink tubing
- (4) DT terminal
- (5) Hydraulic pliers
- (6) Heat gun

# B Grid Codes

 **NOTE**

The grid codes are subject to change. The listed codes are for reference only.

Set the correct grid code for the Smart PCS based on regions and application scenarios.

No.	Grid Code	Description	LUNA2000-200KTL-H1
1	IEC61727-MV800	IEC 61727 medium-voltage standard power grid (50 Hz)	Supported
2	Chile-MV800	Chile power grid	Supported
3	TAI-PEA-MV800	Thailand power grid	Supported
4	SAUDI-MV800	Saudi Arabia power grid	Supported
5	EN50549-MV800	Ireland power grid	Supported
6	IEC 61727-MV800-60HZ	General power grid	Supported
7	CEI0-16-MV800	Italy medium-voltage power grid	Supported
8	NIGERIA-MV800	Nigeria medium-voltage power grid	Supported
9	VDE-AR-N4120-HV800	VDE 4120 standard power grid	Supported
10	CHILE-PMGD-MV800	Chile PMGD medium-voltage power grid (800 V)	Supported
11	GHANA-MV800	Ghana medium-voltage power grid (800 V)	Supported
12	TAI-MEA-MV800	Thailand medium-voltage power grid	Supported

No.	Grid Code	Description	LUNA2000-200KTL-H1
13	G99-TYPEB-HV-MV800	UK G99_TypeB_HV medium-voltage power grid	Supported
14	G99-TYPEC-HV-MV800	UK G99_TypeC_HV medium-voltage power grid	Supported
15	G99-TYPED-MV800	UK G99_TypeD medium-voltage power grid	Supported
16	VDE-AR-N4110-MV800	Germany medium-voltage power grid (800 V)	Supported
17	NTS-MV800	Spain medium-voltage power grid	Supported
18	PERU-MV800	Peru medium-voltage power grid	Supported
19	AUSTRIA-MV800	Austria Type B medium-voltage power grid	Supported
20	POLAND-EN50549-MV800	Poland medium-voltage power grid	Supported
21	CHINA-GBT34120-MV800	China medium-voltage power grid for commercial energy storage	Supported
22	Japan-MV550-50Hz	Japan medium-voltage power grid	Supported
23	Japan-MV550-60Hz	Japan medium-voltage power grid	Supported
24	ABNT NBR 16149-MV800	Brazil power grid	Supported
25	UTE C 15-712-1-MV800	France power grid	Supported
26	Philippines-MV800	Philippines power grid	Supported
27	NRS-097-2-1-MV800	South Africa power grid	Supported
28	Jordan-Transmission-MV800	Jordan power grid	Supported
29	Jordan-Distribution-MV800	Jordan power grid	Supported
30	DUBAI-MV800	Dubai power grid	Supported
31	IEEE 1547-MV800	IEEE 1547 standard power grid	Supported
32	C10/11-MV800	Belgium power grid	Supported
33	IEC61727-MV800	IEC 61727 medium-voltage standard power grid	Supported





No.	Grid Code	Description	LUNA2000-200KTL-H1
34	Mexico-MV800	Mexico power grid	Supported
35	SA_RPPs-MV800	South Africa power grid	Supported
36	Israel-MV800	Israel power grid	Supported
37	AUSTRALIA-NER-MV800	Australia NER standard power grid	Supported
38	RD1699/661-MV800	Spain medium-voltage power grid	Supported
39	Israel-HV800	Israel high-voltage power grid (161 kV)	Supported
40	AUSTRIA-HV800	Austria medium-voltage power grid (type D)	Supported
41	DENMARK-EN50549-MV800	Denmark power grid	Supported
42	FINLAND-EN50549-MV800	Finland power grid	Supported
43	EN50549-SE-MV800	Sweden power grid	Supported
44	CEPM-MV800	Dominican Republic medium-voltage power grid	Supported
45	SA-BESF-L-MV800	South Africa BESF-L medium-voltage power grid	Supported
46	SA-BESF-H-MV800	South Africa BESF-H medium-voltage power grid	Supported
47	UZBEKISTAN-MV800	Uzbekistan power grid	Supported
48	CZECH-EN50549-MV800	Czech Republic power grid	Supported
49	BRASIL-ANEEL-MV800	Brazil power grid	Supported
50	AUSTRALIA-NER-MV800	Australia power grid	Supported
51	SENEGAL-MV800	Senegal power grid	Supported

# C Resetting Password

## NOTICE

You are advised to reset the password in the morning or at night when the solar irradiance is low.

Reset the password only when the AC power is supplied to the Smart PCS from the power grid, diesel generator, or other voltage-source PCSs.

- Step 1** Check that the AC and DC sides of the Smart PCS are both powered on, and indicators  and  are steady green or blinking slowly for more than 3 minutes.
- Step 2** Turn off the AC switch between the AC side of the Smart PCS and the power grid to power off the AC side of the Smart PCS.
- Step 3** Turn off the DC switch between the DC side of the Smart PCS and the ESS to power off the DC side of the Smart PCS.
- Step 4** After the Smart PCS is powered off, complete the following operations within 4 minutes:
1. Turn on the AC switch and wait for about 90s or until the Smart PCS indicator  blinks.
  2. Turn off the AC switch, and wait for about 30s or until all LED indicators on the Smart PCS panel turn off.
  3. Turn on the AC switch and wait for about 90s or until the Smart PCS indicator  blinks.
- Step 5** Log in to the app and reset the password within 10 minutes. Otherwise, all parameters of the Smart PCS remain unchanged.

----End

# D Certificate Management and Maintenance

## Preconfigured Certificate Risk Disclaimer

The Huawei-issued certificates preconfigured on Huawei devices during manufacturing are mandatory identity credentials for Huawei devices. The disclaimer statements for using the certificates are as follows:

1. Preconfigured Huawei-issued certificates are used only in the deployment phase, for establishing initial security channels between devices and the customer's network. Huawei does not promise or guarantee the security of preconfigured certificates.
2. The customer shall bear consequences of all security risks and security incidents arising from using preconfigured Huawei-issued certificates as service certificates.
3. A preconfigured Huawei-issued certificate is valid from the manufacturing date until October 2041.
4. Services using a preconfigured Huawei-issued certificate will be interrupted when the certificate expires.
5. It is recommended that customers deploy a PKI system to issue certificates for devices and software on the live network and manage the lifecycle of the certificates. To ensure security, certificates with short validity periods are recommended.

## Application Scenarios of Preconfigured Certificates

File Path and Name	Scenario	Replacement
f:/ca.crt	Two-way certificate authentication is performed when the Smart PCS communicates with the SACU through Modbus-TCP.	For details about how to replace a certificate, contact technical support engineers to obtain the corresponding security maintenance manual.
f:/tomcat_client.crt		
f:/tomcat_client.key		

# E Contact Information

---

If you have any questions about this product, please contact us.



<https://digitalpower.huawei.com>

Path: **About Us > Contact Us > Service Hotlines**

To ensure faster and better services, we kindly request your assistance in providing the following information:

- Model
- Serial number (SN)
- Software version
- Alarm ID or name
- Brief description of the fault symptom

 **NOTE**

EU Representative Information: Huawei Technologies Hungary Kft.  
Add.: HU-1133 Budapest, Váci út 116-118., 1. Building, 6. floor.  
Email: hungary.reception@huawei.com

# F Digital Power Customer Service

---



<https://digitalpower.huawei.com/robotchat/>

---

# **G** Acronyms and Abbreviations

---

## **F**

**FE** Fast Ethernet

## **G**

**GE** Gigabit Ethernet

## **L**

**LED** Light Emitting Diode

## **R**

**RCMU** Residual Current  
Monitoring Unit

## **S**

**Smart PCS** Smart Power Control  
System

## **W**

**WLAN** Wireless Local Area  
Network